



Catalogue Domestic Technology

21/22

We would be pleased to help you with any questions you may have. You can reach your contact person on +49 7135 102-

Sales group domestic technology

Tank. Heating. Water Technology.

Germany:	North	-121
	Centre	-169
	South	-124
	Gas analysis	-255

Export: -132

Service and repairs

Hotline -211

www.afiso.com/contact

The catalogue has been presented by:

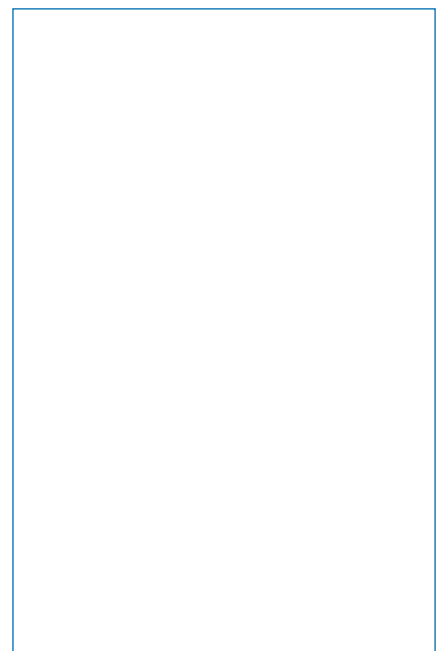



Dear business partner

Whether you are looking for products for groundwater protection, flue gas monitoring or industrial measuring and control technology solutions for process engineering – the AFRISO range provides proven, competitively priced series products.

The catalogue DOMESTIC TECHNOLOGY covers all products for safety and measuring equipment for heating systems, solutions for energy savings and water technology as well as alarm units, sensors, actuators and smart building systems for wireless building automation.

The catalogue INDUSTRIAL TECHNOLOGY comprises the complete range of high-quality measuring instruments and system solutions for pressure, temperature and level as well as customised, industrial solutions for stationary gas analysis – for your specific industrial application.

The catalogue PORTABLE MEASURING INSTRUMENTS covers certified mobile service measuring instruments for flue gas analysis as well as testing and inspection equipment for maintenance and diagnostics. Ready to be used in any industry.

In addition, we develop and manufacture complex customised products as well as complete system solutions – precisely to your specifications. Going against the general trend, we insist on a high degree of vertical manufacturing integration from our own tool design and construction department all the way to fully automatic assembly machines for electronic components. This makes us fast, flexible and independent.

For us, globalisation is an opportunity to market our products – manufactured in Germany and Europe – on a global scale.

As a medium-sized company, we place particular importance on personal contact with you. There are many factors that set AFRISO apart from others – one of them is the people who make up the company. Competent experts provide you with optimum solutions – both technically and economically. And whenever you need it, a well trained team of service experts is at your disposal.

We look forward to a successful cooperation.

Best regards,

A handwritten signature in blue ink that reads "Matthias Blasinger". The signature is fluid and cursive, written over a white background.

Matthias Blasinger
Managing Director Sales and Distribution
AFRISO-EURO-INDEX GmbH

How to work with this catalogue	From page IV
AFRISO at a glance	From page VII
Level indicators and level controllers	From page 3
Level sensors, overflow prevention systems and PTC thermistor type level controllers	From page 23
Leak detectors, leak monitoring systems and leak protection linings	From page 45
Alarm units, probes and signalling devices	From page 65
AFRISO Smart Home: Intelligent alarm units, sensors and actuators with EnOcean® wireless for building automation	From page 91
Equipment for fuel oil storage tanks and oil carrying pipes	From page 123
Equipment for heating systems, boiler rooms and chimneys	From page 151
Equipment for surface heating and cooling systems	From page 203
Valves and control technology for radiators and hydraulic balancing	From page 237
Equipment for drinking water supply, hot water treatment and rainwater harvesting	From page 283
Mechanical pressure measuring instruments (pressure gauges)	From page 311
Temperature measuring instruments and controllers (thermometers)	From page 349
Appendix – Technical Information	From page 417
Overview portable measuring instruments: CAPBs® sensor modules and BlueLine measuring instruments	From page 406
Index	From page 445

Contents and Product Range

Level – Continuous: Mechanical, pneumatic, hydrostatic
Level – Switches: Float

1

Universal withdrawing system with level sensor chain for battery tank facilities, PTC thermistor level sensors for indoor tanks, PTC thermistor level sensors for outdoor tanks, level sensor testers, overflow prevention systems with EX and WHG approval, level controllers

2

Leak detectors - sight glass principle, liquid-based leak detectors, vacuum/pressure type leak detectors, tank protection packages, inner linings for fuel oil, diesel, AdBlue® and rainwater

3

WATCHDOG LINE alarm units, leak detectors with probes (PTC thermistor, photoelectric, conductivity), drip pans, gas alarm units for households, domestic/building applications, signalling devices, additional alarm units, gas sensors, test gas units, gas detectors

4

Water valves, water sensors, temperature and pressure measuring instruments, tank contents indicators, smoke alarms, heat alarms, temperature controllers, room temperature sensors, wireless transmitters (temperature/humidity), actuators for radiators, CO₂ sensors, rocker switches, door/window contacts, indoor sirens, wireless gateways, mobile apps

5

Mounting accessories, tank fittings, overpressure devices, tank withdrawal systems, anti-siphon valves, tester for anti-siphon valves, pull cord, screw connections, fuel oil filters, filter inserts, automatic fuel oil de-aerators

6

Motorised boiler room vents, draft stabilisers, boiler water low level alarms, thermal safety valves, boiler safety group assemblies, safety valves, filling fittings, quick air vents, connection assemblies for expansion vessels, anti-tamper cap valves, flow meters, mixing valves, pump assemblies for heating and solar, bypass valves, air/sludge separators

7

Single room temperature controllers, terminal blocks for controllers, room temperature sensors, room thermostats, thermostatic actuators, mechanical single room controller RTL-Box, stainless steel heating circuit manifolds, pump assemblies for manifold systems, OEM pump assemblies: [Surface heating and cooling systems](#), [geothermal systems and drinking water](#)

8

Valves and control technology for hydraulic balancing: [Valve bodies with measuring/adjustment function](#), [adjustable dynamic valve bodies](#), [lockshield valves](#), combination blocks, screw fittings with measuring function, handheld measuring instruments and apps, valves and control technology for radiators: Valve bodies, lockshield valves, combination blocks, thermostat control heads

9

Water filters, domestic water system centre, check valves, strainers, boiler safety group assemblies, safety valves, sacrificial anodes, hot water circulation systems, circulation lances and controllers, thermostatic mixing valves, oil tank conversion kits, inner linings for rainwater tanks, accessories for rainwater harvesting, backup controller kits for rainwater storage tanks

10

Bourdon tube pressure gauges, pressure gauges with plastic or copper capillary tube, capsule pressure gauges, differential pressure gauges, Bourdon tube pressure gauges for industrial applications, accessories for pressure gauges

11

Combined thermometers/pressure gauges with plastic or copper capillary tube, bimetal thermometers, standard thermometers, air duct thermometers, industrial thermometers, stainless steel thermometers, combined thermometer/pressure gauges, industrial thermometers, thermostats, safety temperature cut outs, thermostats with housing, resistance thermometers

12

AFRISO service, training, specialised company search, checklists for enquiries, test reports, conversion table for pressure units, information on the Pressure Equipment Directive, certificates, Terms of Delivery

13

How to work with this catalogue

Table of Contents

Our product range covers [measuring, control and monitoring technology for domestic, industrial and environmental applications](#).

This includes products for groundwater protection, flue gas monitoring, efficient use of energy, use of the sun, geothermal and rain as well as a complete range of pressure, temperature and level instruments.

In addition to the products presented in the catalogues, we manufacture special versions to customer specifications. Please enquire.

Finding information

The catalogue DOMESTIC TECHNOLOGY is divided into 13 chapters. A chapter overview is provided on pages II and III. The blue chapter tabs on the side of the page let you easily find the desired chapter. Each chapter contains a detailed table of contents as well as an overview table and the main features of the products in that chapter to help you find the product page you need fast.

To find products, you can also use the comprehensive index in the appendix.

Usually, all information on a product is contained on one page and cross references guide you to other pages for fast and easy access to additional information such as fact sheets.

Enquiries

To make enquiries as simple as possible and to assist you in gathering all the necessary information, the appendix contains a number of checklists for enquiries, e.g. for pressure gauges, thermometers and level indicators.

Contact person

Our sales department is divided into three industry-specific sales groups. Please visit www.afriso.com/contact or see the second page of this catalogue for further information on your specific contact person.

Delivery times / stock items

All [stock items](#) have [part numbers printed in blue](#) in the price lists. Please enquire for the delivery times of non-stock items as they vary greatly depending on the product specifications.

Minimum order quantities / packing units

Many products can be manufactured in small quantities – in many cases, you may even order a single piece.

However, for some items there are minimum ordering quantities or packing units. The price list sections provide the appropriate information.



The product package contains the specified number of products or can be delivered in the specified order quantity



An additional package contains the specified number of products

Small order handling fee / minimum order value

For very small orders with net values below € 100 a handling fee of € 15 will be charged. No other minimum order conditions apply.

Return of goods

Goods can only be returned with return note and only up to 3 months after delivery, minimum value of goods for return is € 100,-. Please enquire for a return note at service@afriiso.de. Please note that only standard stock items can be returned; products not available from stock and devices with ATEX approval cannot be returned. For returned stock items we charge 30 % of the price for testing and handling or at least € 40. Shipping costs for returns are to be borne by the customer.

Prices / terms of delivery

Please refer to your local AFRISO representation or get in touch with the AFRISO headquarters for detailed price information and conditions. We will charge a fee of € 10,- per shipment for drop shipping.

Our Terms of Delivery apply (see www.afriso.com or appendix). This catalogue supersedes all previous versions, including previous prices. All prices subject to change; the catalogue may contain printing errors.

Technical modifications

As we are constantly improving our products, we reserve the right to technical modifications without prior notice.

Copyright

Copyright 2020 by AFRISO-EURO-INDEX GmbH.

No part of the catalogue may be reproduced, copied, distributed, translated or in any other way processed without prior written approval of AFRISO-EURO-INDEX GmbH.

AFRISO quality products

AFRISO quality products are continuously being enhanced and are subject to stringent inspections. Quality labels and approvals designate special features and application areas of the products. For certificates and manufacturer's declarations, please refer to chapter 13 or to www.afriso.com, INFO CENTRE > Downloads or to the directly to the product on the website.



All products with the quality label PROOFED BARRIER® are odour-tight. The quality label is awarded by the Fraunhofer-Institut (IVV) in Freising, Germany, exclusively for components that have passed stringent initial and repeat tests.



The Bio-Oil label certifies chemical resistance and guarantees full performance and functionality of the products even if biodiesel, biofuel or additives are used. The percentage shown corresponds to the maximum permissible admixture.



In flood hazard areas, oil must be kept from escaping from oil tank systems as a result of buoyancy, flooding, or damage due to floating refuse. AFRISO products with the label "Suitable for Use in Flood Hazard Areas" meet this requirement. See the individual catalogue pages for details on flood water resistance. After a flood, the information provided in the operating instructions must be observed.



Solar components by AFRISO allow for effective use of thermal solar systems in domestic technology. All labelled products are universally applicable and tuned to each other.



The DVGW is the German technical and scientific association for gas and water. The association is concerned with technical and scientific aspects of the supply of gas and water, implements results in the form of the national German DVGW rules and also contributes to DIN, EN and ISO standards. AFRISO products bearing the DVGW label have been tested and approved in compliance with the stringent safety requirements of the DVGW.



The PED (Pressure Equipment Directive 2014/68/EU) specifies the requirements for selling pressure equipment within the European Union. Please refer to chapter 11 for further details on our mechanical and electronic pressure gauges.



The European Ecodesign Directive covers Energy-related Products (ErP). It went into force in August 2007 and was implemented in the EU member states as separate legislation. This directive is geared towards increased energy efficiency of electronic equipment in order to reduce the negative impact on the environment, such as CO₂ emission. ErP-Ready means that the electronic equipment bearing this logo complies with this directive.



EnOcean – Green. Smart. Wireless. EnOcean is a battery-less wireless technology which allows for maintenance-free sensor solutions. These sensors deliver data for intelligent networks in buildings and for the Internet of Things. The basic idea behind the innovative EnOcean® technology is driven by a simple observation: Wherever sensors capture measured values, the energy state changes as well. A switch is pressed, the temperature changes or the illuminance varies. These processes provide sufficient energy to transmit wireless signals. www.enocean.com

EnOcean-ready

The label "EnOcean-ready" on the WATCHDOG LINE alarm units indicates that the PCB of the device features a slot for the EnOcean® TCM 320 wireless module. It is sufficient to plug in the wireless module to integrate the device into a smart home system based on EnOcean®.



Suitable devices any application. In order to be able to optimally focus on the requirements of the individual target markets, we have divided our product portfolio into the areas of DOMESTIC TECHNOLOGY, PORTABLE MEASURING INSTRUMENTS and INDUSTRIAL TECHNOLOGY. The corresponding icons allow for easy assignment to main industries and provide for easy navigation in our complete range of products. In addition, we offer customised OEM solution in these areas.

How to work with this catalogue

AFRISO catalogue DOMESTIC TECHNOLOGY: Clear structure and layout

- Clear user guidance
- Detailed tables of contents
- Overview tables with product features
- Easy-to-find tabs
- Everything at a glance

Overview table to help you make your selection with comparison of product features.

The overview table lists various level indicators such as 'Indoor tanks', 'Outdoor tanks', 'Electrically insulating tanks', etc., and compares their features across different product lines like 'Optical', 'M5-Prot-R', 'Ultras', etc.

Index

The index table lists product categories such as 'Level sensors (EL)', 'Level sensor battery ATEx-certified', 'Leak detector LAG-14 ER', etc., and provides the corresponding page numbers for each.

Navigation bar organised according to relevant selection criteria for fast orientation even when browsing through the catalogue.

Tab

Digital tank contents indicator DTA 10

- For fuel oil EL, L, diesel fuel, biodiesel, water and other media with a density from 0.5 to 1.5 g/cm³
- Universal application in tanks of height of up to 4 m
- Push-to-Read function: Fast start with just a push of a button

Application: Location-independent level measurement with digital display and minimum level alarm (reserve level alarm) with a single measurement. Suitable for tanks up to 400 cm liquid level. For fuel oil EL, L or diesel fuel, FAME, 100 % as biodiesel (EN 14214, water for drinking water) and AdBlue.

Description: The electro-pneumatic tank contents indicator DTA 10 consists of a battery-operated control unit with digital display and a measuring line. Measured values are displayed in litres, % and liquid level (cm). Simple operation and setup via three function keys. Measurements are requested by means of pressing the control key (Push-to-Read function). If the level falls below a minimum level that is freely adjustable as a percentage, the backlight of the display flashes red to indicate an alarm during the measurement. Standard tank shapes (linear, cylindrical and horizontal) are stored. Measuring line connection for hose with 4 mm inside diameter.

Technical data:

- Functions:** Push-to-Read level measurement
- Measuring range (tank height):** 0-400 cm (fuel oil) 0-250 cm (water)
- Measuring accuracy:** ±3.0 cm
- Operating temperature range:** Ambient: -30 to +50 °C Storage: -20 to +65 °C Medium: 0 to 50 °C
- Display:** Multi-coloured, backlit graphical display (50 x 50 mm): Blue = Operation Red = Alarm Green = Setup Indication of litres (5 digits), % or liquid level in cm
- Measuring line:** PVC hose ø x l: 1 mm Length 20 m Balance chamber stainless steel

Supply voltage: 9 V monobloc battery

Visual alarm: Backlight flashes red during measurement process

Housing: Wall mounting housing made of impact-resistant plastic (ABS) W x H x D: 100 x 188 x 85 mm Degree of protection: IP 20 (EN 60529)

Scope of delivery: Control unit with 9 V monobloc battery Pneumatic type 2 20 m measuring line with bottom part connection kit for G1/2, G1, G1 1/2 and G2, 30 m cable clips, hose connector (4 x 4 mm), mounting accessories

PG: 4	Part no.	Price €
DTA 20 E: Smart Home-enabled version based on Basis EnOcean wireless see page 100.	M 52145	203.00
DTA 10 with Pneumofix type 2	M 52155	192.30
DTA 10 without Pneumofix type 2	L 52148	20.80

Power supply unit 9 V for DTA series

Product advantages and main benefits

Quality labels provide information about special characteristics or application areas of products.

Application examples provide a clear picture of the application and available options.

Appropriate **accessories** with page reference.

Clearly structured **product descriptions**, divided into application, description and technical specifications.

The **Info box** provides you with important information, e.g. about order processing, cross references and much more.

Order information table with part numbers, prices and packing unit details plus options/extra charges.

AFRISO support centres – close by, guaranteed.

Sites in Germany

- ▲ AFRISO sales office/field staff
- ▲ AFRISO production site

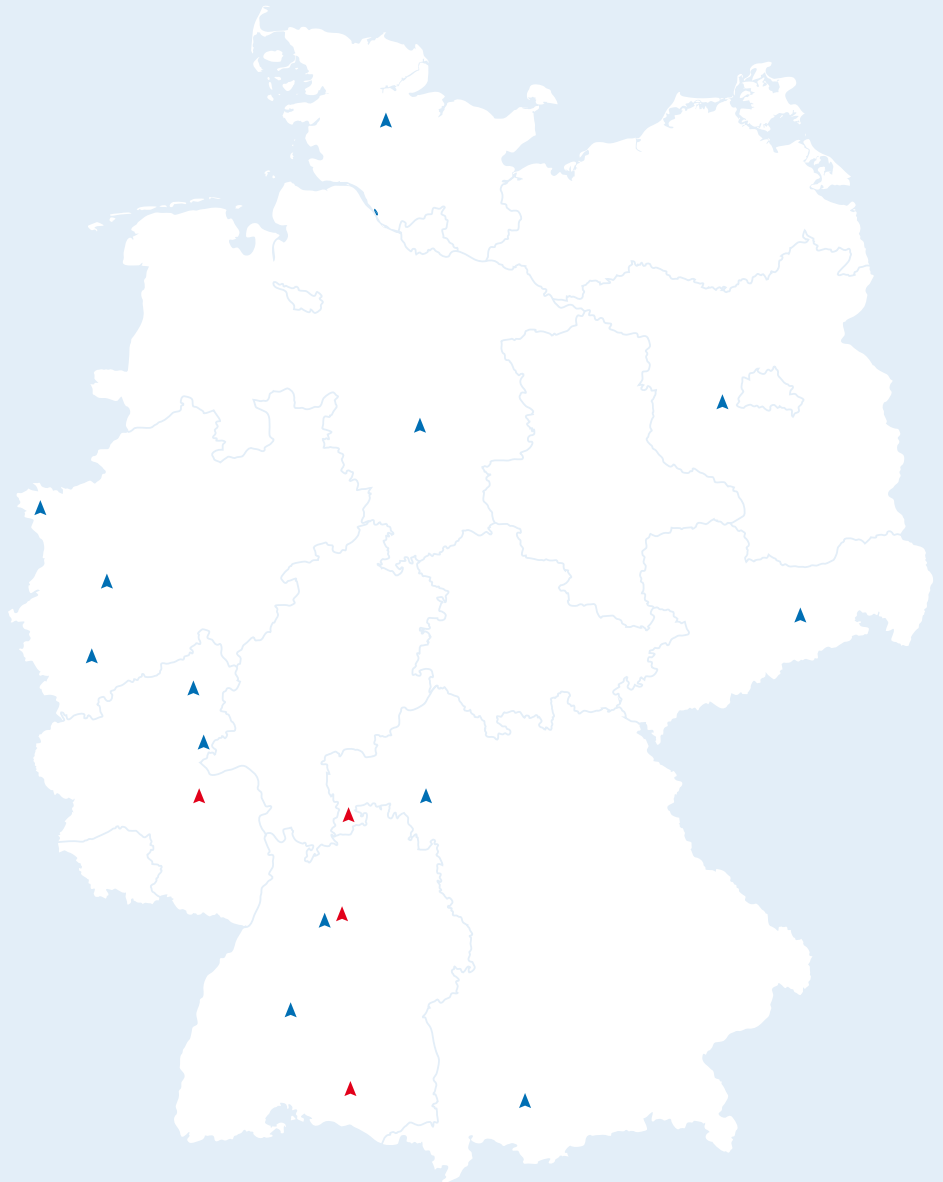

We ensure that you get professional, personal service.

With a staff of more than 80 field and internal experts! Please visit www.afriso.com/contact for further information on your specific contact person.

Business hours:

Monday – Thursday: 7.30 a.m. – 12.00 a.m. and
1.00 p.m. – 4.30 p.m.

Friday: 7.30 a.m. – 12.30 p.m.

Made in Germany

Headquarters

AFRISO-EURO-INDEX GmbH
Lindenstr. 20
74363 Güglingen
Baden-Württemberg



A staff of more than 550 are at work for you in our four German production sites.



Stocks and logistics

Maximum availability, short delivery times. Our range comprises more than 25,000 different products. More than 3,000 of them are on stock. A total of more than 1,500,000 individual devices and instruments are available ex stock.

The new logistics centre will start operations in 2021 as a global distribution centre to ensure fast access to AFRISO products with lean logistics processes.





AFRISO development centre
for portable measuring instruments



Plant Illmensee
Systronik GmbH
Gewerbestr. 57
88636 Illmensee
Lake Constance/Baden-Württemberg



Plant Amorbach
AFRISO-EURO-INDEX GmbH
Friedhofstr. 3
63916 Amorbach
Odenwald/Bavaria



Plant Amorbach – Production of linings
AFRISO-EURO-INDEX GmbH
Von-Stein-Straße 17
63916 Amorbach
Odenwald/Bavaria



Alsenz plant
GAMPPER GmbH
Niedermoscheler Str. 2
67821 Alsenz
Rhineland-Palatinate

Close, direct customer contact as a result of consistent, international alignment.

On site worldwide for you

A tightly woven network of branches, distribution partners and service centres guarantees optimum consulting and delivery. More than 1,000 AFRISO employees respond to country-specific challenges with close customer contact and individual service on site – worldwide!

AFRISO Group

 **Headquarters**
AFRISO-EURO-INDEX GmbH
Lindenstr. 20
74363 Güglingen, Germany
Tel. +49-7135-102-0
Fax +49-7135-102-147
info@afriso.de
www.afriso.de

 **VELTA-EUROGAUGE S.A.**
17 a rue des Cerisiers
67117 Furdenheim, France
Tel. +33 388 28 23 95
info@groupeafriso.fr
www.afriso.fr

 **AFRISO-EUROGAUGE Ltd.**
Unit 4 Satellite Business Village
GB-Fleming Way, Great Britain
Crawley RH10 9NE
Tel. +44-1293-658360
sales@afriso-eurogauge.co.uk
www.eurogauge.co.uk

 **EURO-INDEX bvba**
607, Leuvensesteenweg
1930 Zaventem, Belgium
Tel. +32-2-7579244
info@euro-index.be
www.euro-index.be

 **EURO-INDEX B.V.**
Rivium 2e straat 12
2909 LG Capelle a/d IJssel
The Netherlands
Tel. +31-10-2888000
info@euro-index.nl
www.euro-index.nl

 **AFRISO AG**
Hauptstr. 31
9434 Au/SG, Switzerland
Tel. +41-71-7443344
office@afriso.ch
www.afriso.ch

 **AFRISO-EURO-INDEX GmbH**
Reichshofstr. 7a
6890 Lustenau, Austria
Tel. +43-5577-83255
office@afriso.at
www.afriso.at

 **AFRISO IBÉRICA**
Crta. Rubí-Sabadell, km 13,
nave 88 A
08191 Rubí (Barcelona), Spain
Tel. +34 9 35 88 12 52
antonio.garcia@afriso.com
www.afriso.com

 **AFRISO-EURO-INDEX KFT**
Kelenföldi út 2.
1115 Budapest, Hungary
Tel. +36 1 2212496
info@afriso.hu

 **AFRISO spol.s r.o.**
Komerční 520
251 01 Nupaky, Czech Republic
Tel. +42-2-72953636
info@afriso.cz
www.afriso.cz

 **AFRISO SP. Z O.O.**
Szalsza/k. Gliwice
ul. Koscielna 7
42-677 Czekanow, Poland
Tel. +48 32 330 33 55
info@afriso.pl
www.afriso.pl

 **AFRISO-EURO-INDEX SRL**
Bd. Tudor Vladimirescu No 45 A
050881 Bucuresti, sect.5,
Romania
Tel. +40-21-4100702
info@afriso.ro
www.afriso.ro

 **AFRISO EMA AB**
Kilvägen 2
23237 Ärlöv, Sweden
Tel. +46-40-922050
info@afriso.se
www.afriso.se

 **AFRISO Ltd.**
ul. Zolotorozhsky Val, 11, CTP. 27
Office 225
111033 Moscow, Russia
Tel. +7 495 690 93 87
info@afriso.ru
www.afriso.ru

 **AFRISO Measurement & Control Technology (Suzhou) Co. Ltd.**
Building No. 1,
No. 680, Jianlin Road,
Huqiu District,
Suzhou City, 215151, Jiangsu
Province, P.R. China
Tel. +86 512 6807 9460
info@afriso.cn
www.afriso.cn

 **AFRISO India Pvt. Ltd.**
Unit 17, Electronic Sadan III,
MIDC Bhosari
Pune – 411 026
Maharashtra, India
Tel. +91-202-7129421
nilkanth.jatar@afriso.de
www.afriso.in

 **AFRISO NORTH AMERICA**
2 Homestead Drive
Medway, MA 02053
Tel. +1-508-533-3153
frank.schuldt@afriso.com
www.afriso.com

A total of more 1,000 employees
Export to 65 countries

- ▲ AFRISO production site
- ▲ AFRISO branch office
- AFRISO representation
- AFRISO authorised dealer

AFRISO representations



Hasvold a.s
Lofthusveien 65
0590 Oslo, Norway
Tel. +47-22-658610
salg@hasvold.no
www.hasvold.no



Lyth-Instrument Oy
Peltosaarenkatu 2
11130 Riihimäki, Finland
Tel. +358-19-760330
kari.jalon@lyth.fi
www.lyth.fi



Domestic technology:
Power-Flex ApS
Taffelbays Allé 2
2900 Hellerup, Denmark
Tel. +45-39-628787
info@powerflex.dk
www.powerflex.dk



Industrial technology:
Erik Faergemann A/S
Undalsvej 6
3300 Frederiksværk, Denmark
Tel. +45-6261-1415
info@erik.faergemann.dk
www.erikfaergemann.dk



EURO-CONTROL systems s.r.l.
Via Mancalacqua 20/24
37060 Lugagnano (VR)
Tel.: +39 045 8680444
Fax: +39 045 8680440
info@afriso.it



ADAMI s.r.l.
Via Stiliicone, 20
20154 Milano (MI)
Tel.: +39 02 34934476
Fax: +39 02 34934473
info@adami.it



ELSTAVA Ltd.
Geliu g.2, Avizieniai
14184 Vilnius r., Lithuania
Tel. +370-5-244-2036
info@elstava.lt
www.afriso.lt



EcoTechEnergService
ul. Melezha 1-222 K.1
220113 Minsk, Belarus
Tel. +375 17 293 31 25
etes.igor@gmail.com
www.etes.by



Terviv Ukraine LLC
Olevska Str. 3A apt. 3
03164 Kiev, Ukraine
Tel. +38 044 465 66 65
info@afriso.com.ua
www.afriso.com.ua



Mjerenje i automatizacija d.o.o.
za trgovinu i usluge
Ulica 1. gardijske brigade
Tigrovi 27c
10000 Zagreb, Croatia
Tel. +385 1 558 7789
info@mapping.hr
www.mapping.hr



EVA-SAT SIA
Jaunmoku str. 26
1046, Riga, Latvia
Tel. +371 67893870
rp@evasat.lv
www.evasat.lv



Termomont d.o.o
Lukovac b.b
88345 Sovici-Grude
Bosnia and Herzegovina
Tel. +387 39 670 623
termomont@tel.net.ba



FLOGA S.A
23 km Thessaloniki - Poligros
57006 Lakkia Vasilika, Greece
Tel. +30 239 602 3633
info@floga-sa.gr



Automation Engineering Co. Ltd
No. 19, First Street, Bokharest
Ave.
Postal-Code: 15136-38313
Tehran, Iran
Tel. +98 21 8872 2520 21
info@aec.co.ir
www.aec.co.ir



**EMS Engineering for
Measurement Systems**
10, Mohandeseen Askareen
Naser City, 11371 Cairo, Egypt
Tel. +20-2-24041672
info@ems-egypt.com
www.ems-egypt.com



Netsach Nigeria Limited
5b Jo'babs Dare Close, Off Ad-
eyeri Close, Off Opebi, Ikeja
Lagos, Nigeria
Tel. +234-1-3450157
info@netsachng.com
www.netsachng.com



Intrial S. A. C.
Av. Tomas Marsano 3951
Santiago de Surco, Lima,
15048 - Lima - Peru
Tel.: +51 1 7179595
ventas@intrial.com.pe
www.intrial.com.pe



Crest Solutions FZE
Po. Box. 514080
SAIF-ZONE, Sharjah
United Arab Emirates
Tel.No. +971-6-5730420
sales@crestsolutions-me.com



U-Thong Co. Ltd.
413, 415, 417 Petchkaseam Rd.
Kwangnong-Kangplu, Nongkeam
Bangkok
10160 Thailand
Tel. +66 2808 8571
sales@u-thong.com
www.u-thong.com



Phat Dat Trading Eng. Co.
Ward 13, Bink Thanh District
No. 41/96/18, St. Backbone
Ho Chi Minh City, Vietnam
Tel. +84 08355 31725
info@phatdatcompany.com
www.phatdatcompany.com



Gas analysis:
BYTECC Co., LTD.
RM 303, Sangdo SH Bld., 430
Sangdo 1 dong, Dongjak-gu,
Seoul, Korea
Tel. 82 (0) 22687 6635
bytecc@bytecc.com
www.bytecc.com



Industrial technology:
NMT Co., LTD.
26B 4L Jinjang-Dong, Buk-gu
Ulsan, Korea
Tel. +052-283-1922
nmt@nmts.co.kr
www.nmts.co.kr

Technology for Environmental Protection

AFRISO monitors, controls and protects the elements fire, water, earth and air – in the broadest sense. On the one hand, these elements symbolically stand for the relief and protection of the environment – and on the other, they illustrate our fields of activity:

- Flue gas control
- Energy savings
- Groundwater protection
- Conservation of resources

Product development revolves around our motto "Technology for Environmental Protection". We strive to improve the environment, to make processes which work with greater environmental compatibility and to avoid putting a strain on the environment. With a balanced portfolio of innovations, proven products, systems and services, we offer our customers efficient solutions which are of great benefit.

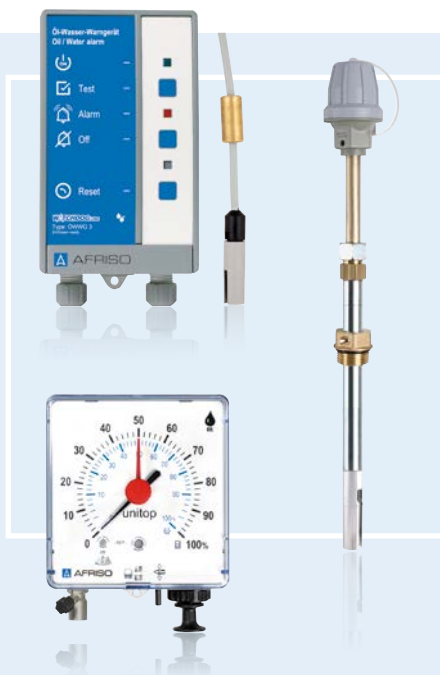

Tank. Heating. Water Technology.

AFRISO provides "Safety for Heating Systems". With a comprehensive range of building technology products, AFRISO prides itself in "Making Heating Systems Safe". Irrespective of whether the heating system uses regenerative energy or fossil fuels. In addition to this extensive range, a large selection of alarm instruments for the fast detection of level, liquid spillage, leakage, gas or smoke is available.

- Mechanical/pneumatic level indicators
- Overfill prevention systems/overfill alarm systems
- Leak detectors/leak monitoring systems
- Inner tank linings
- Equipment for fuel oil storage tanks, oil carrying pipes, boiler rooms, boilers and heating systems
- Heating controllers
- Distribution manifolds for heating, cooling and geothermal systems
- Smart home systems for building automation
- Valves and control technology for radiators and hydraulic balancing
- Equipment for drinking water supply



Gas analysis and service instruments

The BlueLine series is the perfect solution for official measurements, adjustment, servicing, maintenance and repair work. You benefit from an optimally tuned range of measuring instruments which is continuously setting new standards – from basic devices all the way to portable all-in-one flue gas analysers. AFRISO offers gas analysers, gas sampling probes and turnkey analysis systems with data acquisition systems for continuous emission monitoring.

- Portable gas analysers
- Portable measuring instruments, analysers and testers
- Modular sensor module systems
- Gas alarm units
- Stationary gas analysers
- Emission measurement technology
- Measurement data acquisition systems



Pressure. Temperature. Level.

In addition to our comprehensive range of mechanical and electronic pressure, temperature and level instruments, we also offer suitable mounting and installation accessories as well as display, control and evaluation devices.

AFRISO measuring instruments cover the following ranges:
Pressure: 0/2.5 mbar to 0/4,000 bar
Temperature: -50 °C to +1,100 °C
Level: 0/20 cm to 0/250 m

- Pressure gauges
- Accessories for pressure gauges
- Chemical seals
- Pressure transducers
- Bimetal thermometers and gas filled thermometers
- Thermostats
- Resistance thermometers
- Electronic level indicators
- Display, evaluation and control units
- Event reporting systems/communication systems



Special designs and system solutions

In addition to our comprehensive range of standardised, proven off-the-shelf products, we also offer customised special products made exactly to your requirements. We are constantly setting new standards with innovative concepts, e.g. using plastic fittings instead of metal ones or a combination of plastic and brass materials in complex assemblies. Our range does not only cover the delivery of individual sensors, but includes suitable components for power supply and evaluation of the measurement signals. In the case of system solutions, we do the entire engineering for you, all the way to the production of the control unit – ready for operation.

Adapted to your specific requirements

- Housing geometry
- Shape and colour
- Mechanical or electrical connections
- Pre-assembled, tested, ready-to-connect assemblies

Convincing solutions for a wide variety of applications.

We know your industry

AFRISO is at home wherever there is measuring, controlling or monitoring required. As a full-range manufacturer, we offer our customers a broad product portfolio from a single source. A

wealth of experience from numerous applications as well as our knowledge of the requirements in the individual markets make us a reliable partner in your industry. We know what is necessary as

Building technology



The subject of saving energy has been our focus for more than 50 years. From the start, we have supported the move towards geothermal and solar systems as well as the use of biogenous fuels by supplying professional components and assemblies.

Our range for the secure storage of fuel oil and professional equipment for heating systems reduces operating costs, helps make optimum use of fuels, provides timely warnings if hazardous situations arise and constitutes an active contribution to

environmental protection. Innovative measuring instruments for flue gas analysis yield high-precision and reproducible results so that your customers can achieve their goals: the right amount of heat at the right time, low energy consumption and low emissions. And we always respond to sustainable new technologies, for example, by providing compelling sensors and systems for increasing security and convenience in smart homes.

Target markets

- Manufacturer of heat generators
- Manufacturers of solar thermal systems
- System suppliers of surface heating systems
- Tank protection/revision
- Tank manufacturers
- Heating and plumbing system wholesalers
- Electrical wholesalers
- Engineering and planning consultancies
- Smart home and building automation
- Manufacturers of fittings
- Chimney sweeps
- Public institutions, municipalities

a result of our many years as a supplier in the OEM business and our intensive contact with standardisation committees, associations and guilds. We tap our employees' know-how and expertise

in the industry to make our customers' processes simpler, safer and more competitive. In process engineering, in building technology or facilities – you benefit with a strong partner at your side.

Industrial technology and process engineering

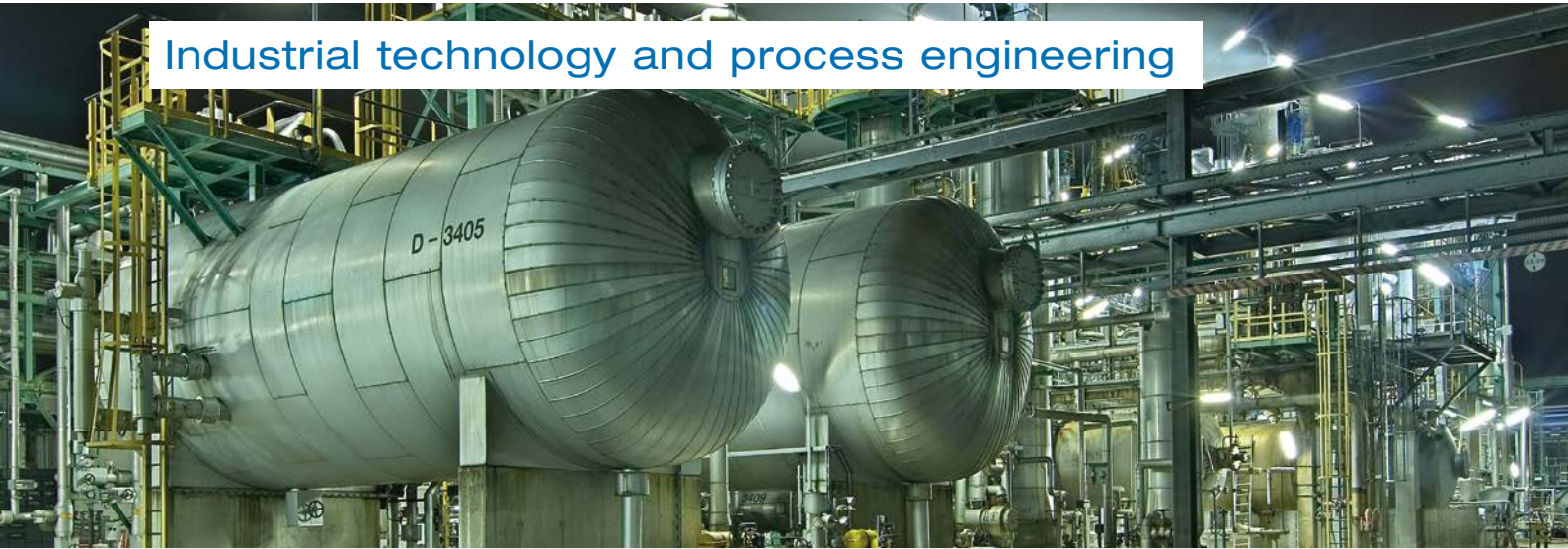

Reliability, precision and a long service life are crucial when it comes to highly automated processes. Our robust measuring devices deliver perfect measurement results and reliably monitor and control simple to highly complex processes – even under the most adverse conditions.

AFRISO solutions meet the pertinent directives and standards. Certificates, for example, for food-quality materials, explosion protection and resistance to media and temperatures attest to this.

AFRISO products meet the requirements

- Wide variety of process connections
- Large selection of materials
- Compact designs
- Hygienic and easy to clean
- Suitable for CIP and SIP
- FDA-listed materials
- Silicone-free versions
- Resistant to corrosive and abrasive media
- High overload safety
- Resistant to vibration and temperature

Target markets

- Machines and plants
- Tanks
- Food and beverages industry
- Chemical industry
- Pharmaceutical industry
- Cosmetics industry
- Biotechnology
- Refineries
- Offshore industry
- Mineral oil industry
- Raw materials industry
- Hydraulic and pneumatics (fluid engineering)
- Medical technology, safety engineering
- Energy production
- Technical trade

The guarantee for high-quality products.

AFRISO quality

Although we serve an extremely wide variety of markets and industries, all AFRISO employees work according to the same values. Reliability, flexibility and independence are the basis of our day-to-day work.

Our corporate culture is marked by a sense of responsibility. We want our employees to be content here with us. Numerous offers for ensuring an optimum work/life balance and continuous optimisation measures within the framework of the occupational health and

safety management system help us show this to the outside world. At AFRISO, quality is systematically planned and, at every stage of product development and production, managed and monitored. This is attested to by national and international approvals and certificates. Quality Assurance as per ISO 9001 and environmental management in accordance with ISO 14001 are a matter of course for us and implemented in every process.

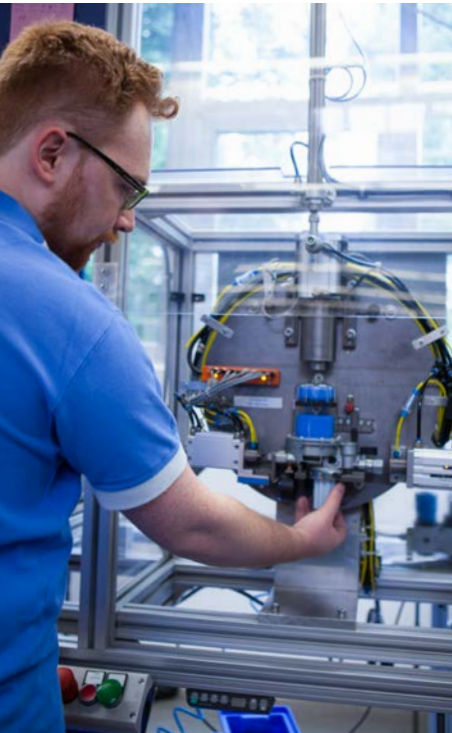

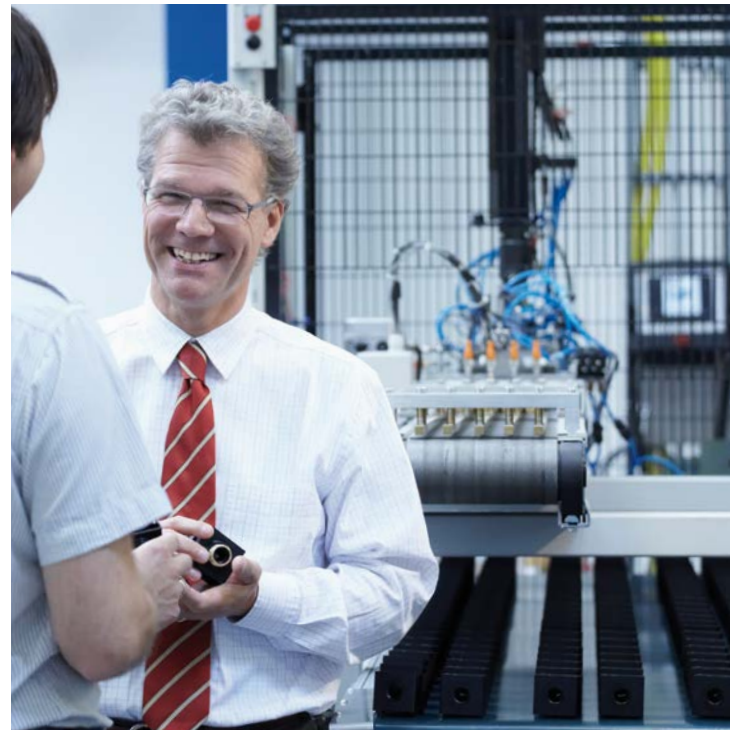

Success for more than 150 years.

Tradition and innovation perfectly in tune



Jürgen and Elmar Fritz,
great-grandsons of the company founder

In 1869, our great-grandfather Adelbert Fritz founded his company in Thuringia. When his son Franz Fritz, our grandfather, entered the company, the company name changed to "Adelbert Fritz & Sohn". AFRISO became a globally renowned brand for temperature and pressure measurement. For 50 years, the company focussed on glass thermometers, medical glass instruments and laboratory equipment; then, a small, thin-walled, circular and concentrically shaped metal sheet completely changed the AFRISO world in the 1920s. Two diaphragm half shells form a capsule element which expands or contracts depending on the pressure. This pioneering invention became the foundation for a host of innovative products: Precision pressure gauges, blood pressure measurement instruments and temperature controllers became the most important products for the time up to 1945 and the new beginning after that.

After World War II, Franz Fritz and his son Georg, our father, rebuilt the company in Kleingartach and in Güglingen in Württemberg. The capsule element was used in pneumatic level indicators which marked our entry to the fuel oil market. Back then, we developed overfill prevention systems and leak monitoring systems for the safe storage of mineral oil products, and technologies for environmental protection became the credo and mission for the future product portfolio. AFRISO secured the market leadership in this sector. Product development revolves around the motto "Technology for Environmental Protection" which is one of the key pillars of our corporate strategy.



Georg Fritz 1922–2004



Franz Fritz 1890–1968



Adelbert Fritz 1846–1918

The early 1960s marked the beginning of the internationalisation of AFRISO: sales and production companies were founded in almost all Western European countries. The oil crisis in 1973/1974 triggered the development of a comprehensive range of products for the efficient and environmentally friendly operation of heating systems. In 1972, we pioneered on the market with the first portable flue gas analyser and we have been a key driver in the development of mobile measurement technology ever since.

After the political change in Eastern Europe, subsidiaries were founded in Hungary, Romania, the Czech Republic, Poland, the Ukraine, Russia and China. Today, the AFRISO family comprises 19 branches. Together with more than 20 representations, we offer our customers optimum consulting and superior supplier's reliability all over the globe.

We are now the fourth Fritz generation to lead the company. We are very well aware of the benefits of a medium-sized company with a long tradition of innovation, run by its owners. The value of a handshake still applies in a figurative sense, and this is something everyone can count on – employees, suppliers and customers. For us, the past is not a closed chapter but an incentive to constantly adapt to changing market requirements. After more than 150 years, we are embracing a promising future, which we would like to shape with trend topics such as "smart home".

Elmar Fritz

Jürgen Fritz

AFRISO milestones



Products for electronic level measurement extend the range for industrial applications.

Founding of sales and production companies in Western Europe. AFRISO renamed AFRISO-EURO-INDEX.

The future lies in the economical and environmentally compatible operation of heating systems. AFRISO launches a broad product portfolio on the market.



Company founded by Adelbert Fritz. Production of glass thermometers, glass instruments and laboratory equipment.

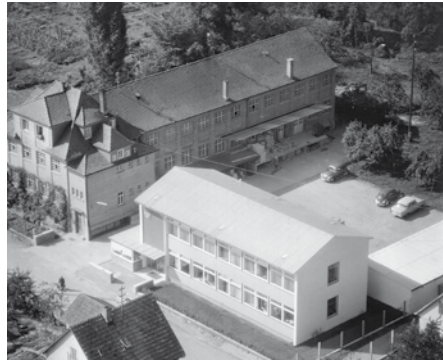

Rebuilding of the company in Kleingartach and Güglingen/Württemberg by Franz Fritz and son Georg Fritz.

1869 1920 1950 1955 1958 1960 1972 1974

A new era begins: Production of capsule elements as the basis for precision pressure gauges, blood pressure measurement devices and temperature controllers.

Market launch: Level indicators for fuel oil tanks. This is followed by overflow prevention systems and leak monitoring systems for the safe storage of oil products.

Market launch of the first portable electronic flue gas analyser.





Integration of SYSTRONIK into the corporate group. Measuring instruments for the industry and the environment are combined in a new division.

Market launch: Product portfolio for solar thermal systems.

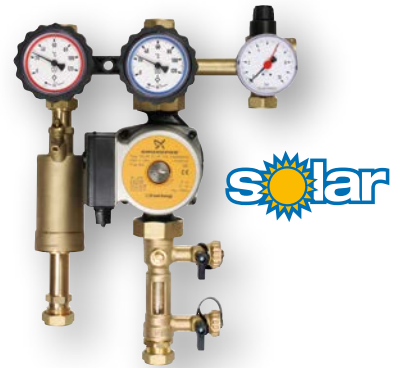

Industry focus: Pressure transducer range DMU 02 Vario with high-flexibility connection technology.



Future-orientated: The Stationary Gas Analysis division engineers and implements system solutions for emission data acquisition.

Internationalisation: Founding of subsidiaries in Eastern Europe and Russia.



1981 1994 1996 2006 2008 2009 2011

Market launch of the first compact manifold made of plastic.



Founding of subsidiaries in South Africa, China, India and South America.



Innovation: AFRISO presents the EUROLYZER ST, the first all-in-one flue gas analyser.

Market launch: Product range for hydraulic balancing.





reddot award 2014
winner



Expansion and new brand identity of the AFRISO group

- New company logo launched:



Measurement technology a step ahead: Modular sensor system AFRISO CAPBs® for BlueLine measuring instruments, smartphones and tablets.

Anniversary year

The family-owned company AFRISO celebrates its birthday. www.afriso.com/150years



2012

2014

2016

2017

2019



Wireless AFRISO smart home system for building automation.



Turnkey solutions for air pollution control:

New limit value for air pollution control force naval operators to retrofit their vessels with exhaust gas cleaning systems. "Scrubbers" ensure compliance with the limit values – AFRISO emission control systems monitor, document and transfer the values to the vessel's control room.

Catalogue Domestic Technology

2021/2022



Unitop



TankControl



HydroFox DMU 08

Level indicators and level controllers

OVERVIEW

Level indicators at a glance	4
------------------------------	---

LEVEL – CONTINUOUS

Dipstick, pipe for dipstick	6
Mechanical level indicators MT-Profil R , Unimes	7
Pneumatic level indicator Unitel	8
Pneumatic level indicator Unitop	9
Mounting accessories for pneumatic level indicators	10
Pneumatic level indicator Unitop-Set AdBlue	11
Digital tank contents indicator DTA 10	12
Digital tank contents indicator for fuel oil, diesel fuel and water DIT 10	13
Hydrostatic level indicator TankControl 10	14
Hydrostatic level indicator HydroFox® DMU 08	16

DISPLAY UNITS

Digital display units DA 10/12/14	17
Digital display and control unit VarioFox® 24	18

LEVEL – LIMIT LEVEL

Level switches Minimelder-R , Maximelder-R	19
----------------------------------------------------------------------------	----

Level indicators at a glance

1



	Dipstick	MT-Profil R	Unimes	Unitel	Unitop	DTA 10/20 E	DIT 10	TankControl
Indoor tanks	•	•	•	•	•	•	•	•
Outdoor tanks	•			•	•	•	•	•
Electrically isolating tanks	•	•	•	•	•	•	•	•
Electrically conductive tanks	•	•	•	•	•	•	•	•
Pressurised tanks								
Unpressurised tanks	•	•	•	•	•	•	•	•
< 1,000 mm		•	•	•	•	•	•	
Up to 2,000 mm	•	•	•	•	•	•	•	•
Up to 2,500 mm	•	•		•	•	•	•	•
Up to 2,900 mm	•			•	•	•	•	•
Up to 3,000 mm				•	•	•	•	•
> 3,000 mm						•	•	•
Liquid media	•	•	•	•	•	•	•	•
Solid media (bulk solids)								
Powdery media								
Electrically isolating media	•	•	•	•	•	•	•	•
Electrically conductive media	•	•	•	•	•	•	•	•
Fuel oil/diesel fuel (EN 590)	•	•	•	•	•	•	•	•
Biofuel/biodiesel (EN 14214)	•	•	•	•	•	•	•	•
Water		•	•	•	•	•	•	•
AdBlue®					•	•		
Measuring principle	Mechanical	Mechanical	Mechanical	Pneumatic	Pneumatic	Pneumatic	Hydrostatic	Hydrostatic
Local display	•	•	•	•	•	•	•	•
Limit level						•		•
Continuous measurement	•	•	•	•			•	•
Analogue output (4–20 mA, 0–10 V)								
Binary output (relay, PNP)								•
EnOcean® wireless						•*		
% liquid level			•	•	•	•		
% volume				•	•		•	•
cm liquid level	•	•				•		•
mm liquid level							•	•
Litres					•	•	•	•
m³							•	•
ATEX								
WHG approval								
Display unit DA 10/12/14								
Display and control unit VarioFox® 24								
Transducer MFU								

* Depends on version

[Page 6](#)
[Page 7](#)
[Page 7](#)
[Page 8](#)
[Page 9](#)
[P. 12/100](#)
[Page 13](#)
[Page 14](#)



Technical specifications, application areas and suitability depend on the product version. See catalogue data sheet and/or operating instructions for options and details.

Dipstick, pipe for dipstick

1



Plastic dipstick

Application For manual level measurement, primarily in cylindrical underground tanks. Suitable for the following media: fuel oil and diesel fuel.

Description Dipstick made of flexible, break-proof plastic with 100 cm brass chain. Excellent readability due to cm graduation.

Technical specifications **Material**
Plastic

Measuring ranges (tank height) / dipstick length

160 cm / 170 cm
200 cm / 210 cm
250 cm / 260 cm
290 cm / 300 cm



Pipe for dipstick

For suspension in 1" pipe. Protects inner tank linings and coatings against damage caused by the dipstick.

Pipe for dipstick, crimped at one end, closed at the other end. Various lengths available, suitable for AFRISO dipsticks.

Material
Steel, galvanised

Connection

Pipe for dipstick	Dipstick
Length 160 cm	Length 170 cm
Length 200 cm	Length 210 cm
Length 250 cm	Length 260 cm
Length 290 cm	Length 300 cm

Cap for dipstick with connection thread G1 female, Zamak



DG: G	PG			Part no.	Price €
Plastic dipstick:					
Length 170 cm, measuring range 160 cm*	1	1	-	20010	
Length 210 cm, measuring range 200 cm*	1	1	-	20011	
Length 260 cm, measuring range 250 cm*	1	1	-	20012	
Length 300 cm, measuring range 290 cm*	1	1	-	20013	
Cap for pipe for dipstick G1 female x G1¼	2	1	140	20464	
Pipe for dipstick 160 cm*	3	1	-	71315	
Pipe for dipstick 200 cm*	3	1	-	71320	
Pipe for dipstick 250 cm*	3	1	-	71330	
Pipe for dipstick 290 cm*	3	1	-	71335	

* Extra shipping charges apply for dipsticks and pipes for dipsticks (all lengths).

Mechanical level indicators

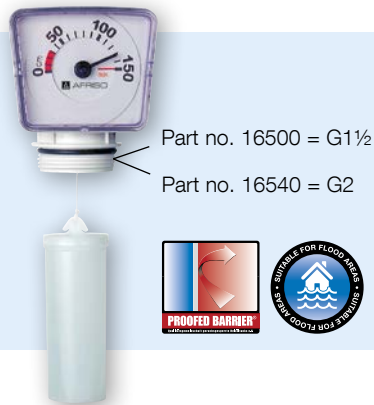

MT-Profil R - G1½ and - G2

Application For continuous level measurement in tanks containing fuel oil EL, diesel fuel, biodiesel and water. For tanks heights from 0 to 250 cm. Suitable for use in flood hazard areas.

Description Universal, mechanical level indicator with plastic planetary gear. Measuring range is adjustable from 0 to 250 cm by reversible scale.

With reversible scale 0–150 cm and 0–250 cm for fast adaptation to the tank height. Odour-tight. Watertight up to 10 m water column.

Technical specifications **Measuring range (tank height)**
0/150 to 0/250 cm

Displayed values
0/150 or 0/250 liquid level in cm

Connection thread
G1½ or G2

Housing / float
Display: ABS, impact-resistant
Float: PE-HD

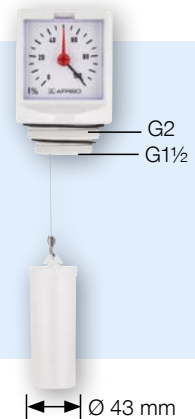

Unimes

For continuous level measurement in tanks containing fuel oil EL, diesel fuel, biodiesel and other low-viscosity media which do not attack materials of the indicator. For tank heights from 900 to 2,000 mm.

Universal mechanical level indicator with fully adjustable brass and nickel silver movement. The pointer deflection amounts to 280° at tank heights and diameters from at least 900 mm to 2,000 mm maximum. The contents is indicated in % liquid level. With reference pointer for consumption monitoring.

Measuring range (tank height)
0/900 to 0/2,000 mm

Displayed values
0/100 % liquid level

Connection thread
G1½ and G2

Housing / float
Display: ABS, impact-resistant
Window: SAN
Float: PE-HD



See page 10 for suitable reducers.

DG: G, PG: 1			Part no.	Price €
Unimes	1	-	11500	
MT-Profil R - G1½	1	50	16500	
MT-Profil R - G2	1	50	16540	
Reducer G2 x G1½	10	-	20903	

Pneumatic level indicator Unitel



1



- No power supply required
- Reference pointer for easy consumption monitoring
- Zero correction possible
- For remote measurements up to 50 m

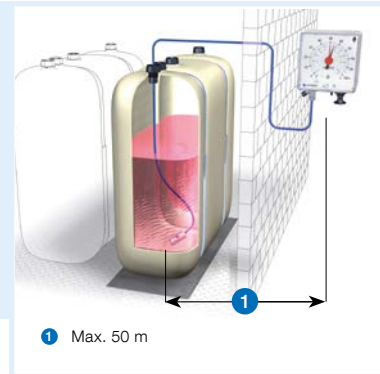

Application For level measurement in tanks containing fuel oil, diesel fuel and rainwater. For tank heights from 900 to 3,000 mm (depends on version). Suitable for use in flood hazard areas and for remote measurement up to 50 m.

Description Universal, pneumatic level indicator with capsule movement. The tank height is fully adjustable. Measuring accuracy $\pm 3\%$ of full scale value. A dual scale facilitates measurements in rectangular tanks (= linear tanks) and cylindrical tanks. Indication in % volume (Unitel) or % liquid level (Unitel for water). Impact-resistant plastic housing for wall mounting. With zero correction and integrated over-pressure safety device. Reference pointer for easy consumption monitoring. Connection for pipe or hose (6 mm outside diameter, universal) for tight mounting of the measuring line (e.g. Pneumofix). Watertight up to 10 m water column.

Technical specifications

Medium

Fuel oil or diesel fuel (density = 0.84 g/cm³) or water (density = 1 g/cm³) for Unitel for water

Measuring range (tank height)

0/3,000 mm (part no. 72500, fuel oil)
0/2,500 mm (part no. 72511, water)

Measuring accuracy

$\pm 3\%$ of full scale value

Operating temperature range

Ambient: -5/+55 °C

PVC hose (accessory)

For measuring line extension. 20 m PE measuring line 4 x 1 mm with hose extension piece

Scale (displayed values)

Unitel: Dual scale 0/100 % volume
Outer for rectangular tanks,
inner for cylindrical tanks
Unitel for water: 0/100 % liquid level

Housing

Wall mounting housing made of impact-resistant plastic with integrated hand pump
W x H x D 145 x 135 x 65 mm

i

See chapter 10 for more products for rainwater harvesting.

DG: G, PG: 1			Part no.	Price €
Unitel for fuel oil tanks	1	-	72500	
Unitel for water tanks	1	-	72511	
Accessories				
PVC hose Ø 4 x 1 mm, 20 m	1	-	20696	
Hose connector 4 x 4 mm	1	25	43945	

Pneumatic level indicator Unitop



- No power supply required
- Consumption monitoring with date indication
- Zero correction possible
- Sturdy brass connector for reliable and tight installation of the measuring line
- For remote measurements up to 50 m

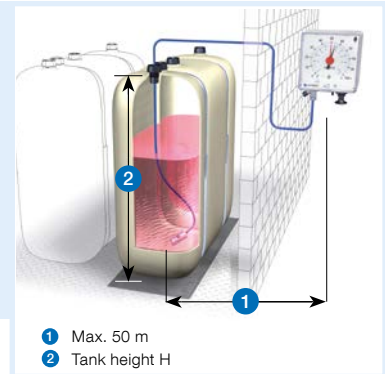

Application For level measurement in tanks containing fuel oil and diesel fuel. For tank heights from 900 to 3,000 mm (depends on version). Suitable for use in flood hazard areas and for remote measurement up to 50 m.

Description Universal, pneumatic level indicator with capsule movement. The tank height is fully adjustable. Measuring accuracy $\pm 2\%$ of full scale value. A dual scale facilitates measurements in rectangular tanks (= linear tanks) and cylindrical tanks. The basic version indicates % of volume so that it is independent of the tank shape. Impact-resistant plastic housing for wall mounting. With zero correction at the front side, reference pointer and date indication for easy consumption monitoring; with integrated pressure relief device. The mechanism carrier of extremely rugged plastic is separated from the housing for stable zero point and high measurement accuracy. Sturdy brass connector with pressure screw for pipe or hose ($\varnothing 6$ mm) for tight installation of the measuring line. A vent screw, integrated in the connector, allows you to check the zero setting of the pointer. Watertight up to 10 m water column.

Technical specifications **Medium** Fuel oil or diesel fuel (density = 0.84 g/cm^3)

Measuring range (tank height) 0/900 to 0/3,000 mm (part no. 28000)

Measuring accuracy $\pm 2\%$ of full scale value

Operating temperature range
Ambient: $-5/+55 \text{ }^\circ\text{C}$
Storage: $-5/+55 \text{ }^\circ\text{C}$

Scale (displayed values)
Dual scale 0/100 % volume
Outer for rectangular tanks,
inner for cylindrical tanks

Housing
Wall mounting housing made of impact-resistant plastic with integrated hand pump
W x H x D: 155 x 166 x 73 mm

Scope of delivery
Level indicator with connection kit and screws,
Litre scales for cylindrical tanks 3,000/5,000,
7,000/10,000, 16,000/20,000

i
See page 11 for
Unitop for AdBlue®.

DG: G, PG: 1			Part no.	Price €
Unitop 3000	1	-	28000	

Mounting accessories pneumatic level indicators

1

Pneumofix type 2

Description Complete, universal mounting kit for pneumatic level indicators. Can be used for tanks of up to 4,000 mm in height or diameter. Consisting of screw fitting with dual thread G1½ and G1, reducer G1 x 1½ x 2. Standpipe in tank with balance chamber. PVC measuring line, 20 m with 30 nail cable clips, hose connector (4 x 4 mm) and mounting accessories. Suitable for use in flood hazard areas. Watertight up to 10 m water column. If no connection socket is available at an individual tank, it is recommended to use Euroflex (see page 128).



Pneumofix

PVC hose Ø 4 x 1 mm

Description For extending the measuring line of pneumatic level indicators. Consisting of: 20 m PE measuring line 4 x 1 mm with hose extension piece. Suitable for use in flood hazard areas. Watertight up to 10 m water column.



PVC hose with mounting accessories

Condensate trap KG 2

Description For protection of pneumatic level indicators against condensate. Made of high-grade, impact-resistant plastic. The condensate trap can be easily unscrewed for emptying. Universal connections for hose or pipe with 6 mm outside diameter. Suitable for use in flood hazard areas. Watertight up to 10 m water column.

Scope of delivery:
KG 2, incl. mounting material (screws, screwed connections)



Condensate trap KG 2

Reducers/adapters

Description Reducer 2 x 1½
Reducer G2 x G1½ made of grey plastic (ABS).

Reducer 1½ x 1
Reducer G1½ x G1 made of grey plastic (ABS).

Description Flange adapter for battery tanks
Flange adapter G1 or G1½ made of black plastic (ABS).



Mounting kit for battery tanks
For mounting of Unitel, Unitop or DTA if all process connections at the tank are used.



Reducers

Flange adapter

Mounting kit

PG: 1	DG			Part no.	Price €
Pneumofix type 2	G	1	-	20142	
PVC hose Ø 4 x 1 mm, 20 m, with mounting accessories	G	1	-	20696	
Hose connector 4 x 4 mm	G	1	25	43945	
Condensate trap KG 2	G	1	5	20320	
Reducer 2 x 1½	G	10	-	20903	
Reducer 1½ x 1	G	10	-	20905	
Flange adapter G1½	G	1	10	20900	
Mounting kit for battery tanks	M	1	-	52154	

Pneumatic level indicator for AdBlue® – Unitop-Set AdBlue



- Specially calibrated for AdBlue®
- Universally adjustable
- Easy mounting
- Complete with special mounting kit
- No power supply required

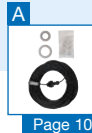

Page 10

Pneumofix type 2

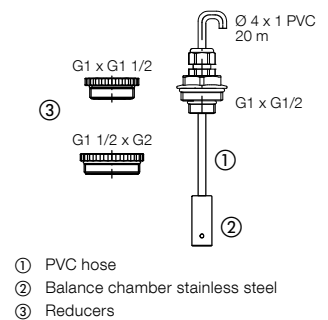

Application For level measurement in tanks containing AdBlue® (density 1.09 g/cm³). For tank heights from 700 to 2,300 mm. Suitable for use in flood hazard areas and for remote indication up to 50 m. The term AdBlue® is the same as "NO_x Reducing Agent AUS 32" and "Urea solution 32.5 %".

Description Universal, pneumatic level indicator with capsule movement. Specially adjusted to the specific weight (density) of AdBlue® = 1.09 g/cm³. Fully adjustable from 700 to 2,300 mm tank height. Measuring accuracy ±2 % of full scale value. Indication in percentage of level. With zero correction at the front side, reference pointer and date indication for easy consumption monitoring; with integrated overpressure safety device. Universal measuring line connection for pipe or hose with an outside diameter of 6 mm. Easy mounting by means of a mounting kit specially designed for AdBlue®. Process connection G1 und G½, standpipe PVC 2.5 m with stainless steel balance chamber, 10 m measuring line PVC 4 x 1 mm, reducer G1 x G1½ x G2. Watertight up to 10 m water column.

Technical specifications

Measuring range
0/700 to 0/2,300 mm tank height

Measuring accuracy
±2 % of full scale value

Operating temperature range
Medium: 0/35 °C
Ambient: -5/+55 °C
(Please observe the pertinent regulations concerning the storage of AdBlue®!)

Scale (displayed values)
0/100 % liquid level

Housing
Wall mounting housing made of impact-resistant Plastic with integrated hand pump
W x H x D 155 x 166 x 73 mm

Process connection
G½ and G1, reducer G1 x G1½ x G2

Standpipe
Plastic PVC
Length 2.5 m balance chamber stainless steel

Measuring line
PVC hose 4 x 1 mm
Length approx. 17 m

Scope of delivery
Level indicator, mounting kit and reducers G2 x G1½ as well as G1½ x G1

i

Make sure to observe all pertinent legislation concerning selection of materials and construction when building storage facilities for AdBlue®. See chapter 2 for suitable overflow prevention systems and chapter 3 for inner tank linings.

DG: G, PG: 1			Part no.	Price €
Unitop-Set AdBlue	1	-	28040	

Digital tank contents indicator DTA 10

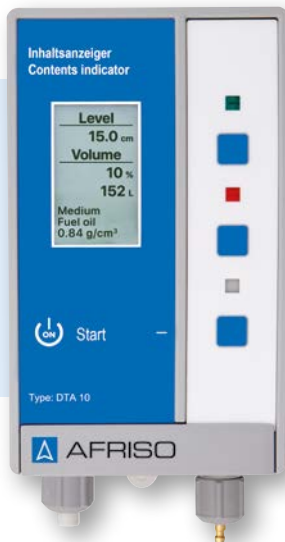

- For fuel oil EL, L, diesel fuel, biodiesel, water and other media with a density from 0.5 to 1.5 g/cm³
- Universal application in tanks of a height of up to 4 m
- Push-to-Read function:
Fast start with just a push of a button



Application Location-independent level measurement with digital display and minimum level signal (reserve level alarm) with a single measurement. Suitable for tanks up to 400 cm liquid level. For fuel oil EL, L or diesel fuel, FAME 100 % as biodiesel (EN 14214), water (no drinking water!) and AdBlue®. In addition, DTA 10 can be used for level measurement with all non-corrosive liquids with a density from 0.5 to 1.5 g/cm³. Remote measurements up to 15 m.

Description The electro-pneumatic tank contents indicator DTA 10 consists of a battery-operated control unit with digital display and a measuring line. Measured values are displayed in litres, % and liquid level (cm). Simple operation and setup via three function keys. Measurements are requested by means of pressing the control key (Push-to-Read function). If the level falls below a minimum level that is freely adjustable as a percentage, the backlight of the display flashes red to indicate an alarm during the measurement. Standard tank shapes (linear, cylindrical and horizontal) are stored. Measuring line connection for hose with 4 mm inside diameter.

Technical specifications

Functions

Push-to-Read level measurement

Measuring range (tank height)

0/400 cm (fuel oil)

0/350 cm (water)

Measuring accuracy

±3.0 cm

Operating temperature range

Ambient: 0/50 °C

Storage: -20/+65 °C

Medium: 0/50 °C

Display

Multi-coloured, backlit graphical display (30 x 50 mm):

- Blue = Operation
- Red = Alarm
- Green = Setup

Indication of litres (5 digits),

% or liquid level in cm

Measuring line

PVC hose 4 x 1 mm

Length 20 m

Balance chamber stainless steel

Supply voltage

9 V monobloc battery

Visual alarm

Backlight flashes red during measurement process

Housing

Wall mounting housing made of impact-resistant plastic (ABS)

W x H x D: 100 x 188 x 65 mm

Degree of protection: IP 20 (EN 60529)

Scope of delivery

- Control unit with 9 V monobloc battery
- Pneumofix type 2:
20 m measuring line with bottom part, connection kit for G½, G1, G1½ and G2, 30 nail cable clips, hose connector (4 x 4 mm), mounting accessories

i

DTA 20 E: Smart Home-enabled version based on Basis EnOcean® wireless see page 100.

PG: 4	DG	Part no.	Price €
DTA 10 with Pneumofix type 2	M	52145	
DTA 10 without Pneumofix type 2	M	52155	
Power supply unit 9 V for DTA series	L	52148	

Digital tank contents indicator DIT 10



- For fuel oil EL, L, diesel fuel, biodiesel and water
- Universal application in tanks of up to 4 m in height or diameter
- No external supply voltage required
- Push-to-read function for extremely long battery service life

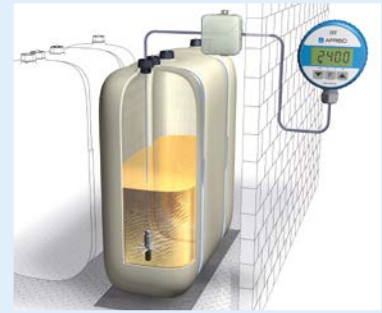

1

Application For level measurement in tanks containing fuel oil EL, L or diesel fuel and FAME 100 % as biodiesel (EN 14214). Specially suitable for underground tanks and basement tanks, also in flood hazard areas. For filling levels from 900 mm to 4,000 mm.

Description The hydrostatic level indicator consists of a control unit with digital display and a submersible probe with integrated pressure measuring cell. High measuring accuracy due to electronic sensor (pressure measuring cell). Simple operation due to device setup via menus. No bearing charts required since all standard tank shapes are stored. Watertight up to 10 m water column.

Technical specifications

Functions

Push-to-read, selection of units, calculation of total volume

Measuring range

0/400 mbar

Measuring accuracy

±1.5 % FS

Operating temperature range

Medium: -5/+70 °C

Ambient: 0/45 °C

Storage: -5/+70 °C

Display

4-digit, 12 mm high LCD 7-segment display with additional symbols

Displayed values

Litres, m³, %, liquid level in mm

Submersible probe

Housing: Stainless steel 304 (1.4301)

Cable: PVC, 6 m with breather tube

Diaphragm: Stainless steel 316 L (1.4435)

Seals: FKM (Viton)

Spacer: POM, PE

Supply voltage

1 x lithium battery 3.6 V (included)

Service life approx. 5 years

Housing

PA6, glass-loaded, blue,

Ø 75 mm, wall mounting

Degree of protection

Control unit: IP 51 (EN 60529)

Submersible probe: IP 68 (EN 60529)

Scope of delivery

- Control unit with digital display
- 5 m connection cable to probe (can be extended by up to 10 m)
- Moisture-proof junction box (IP 54)
- Submersible probe with 6 m submersible cable
- Screw connector kit G1 x G1½ x G2
- Mounting kit for withdrawal flange (PG 9 gland)
- Wall mounting

DG: H, PG: 4	Part no.	Price €
DIT 10	52150	
Spare submersible probe (0/400 mbar)	52153	
Spare battery	68309	

Hydrostatic indicator TankControl 10



1



- For fuel oil EL, L, diesel fuel, biodiesel and water
- Graphical indication of consumption and remaining range
- With visual/audible alarms, Acknowledge button and 2 relays
- Remote measurements up to 15 m

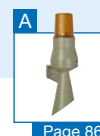

Application Continuous level measurement with graphical display for indication of consumption (history), calculation of remaining range (forecast) and signalling of minimum or maximum levels as well as for level control. For tanks from 1,000 to 4,000 mm liquid level. Suitable for fuel oil EL, L, diesel fuel, FAME 100 % as biodiesel (EN 14214), water (no drinking water!) as well as similar liquids. In conjunction with an additional submersible probe for differential alarm also suitable for detecting level differences in communicating tanks (e.g. battery tanks) which may cause overfilling. It is also possible to connect a floating probe for backflow alarms (drain system, e.g. for rain water harvesting systems) or for additional minimum or maximum alarms. Specially designed for building technology. Suitable for use in flood hazard areas.

Description The hydrostatic level indicator consists of a control unit with numerical and graphical display and a submersible probe with integrated pressure measuring cell. Optionally with additional submersible probe for differential alarm or with floating probe. The system displays either litres, m³, % or liquid level (mm). When the level falls below or exceeds an adjustable minimum or maximum value, the control unit triggers visual and audible (can be acknowledged) alarms. The value for submersible probe 2 is displayed in mm. If an adjustable level difference between submersible probe 1 and submersible probe 2 is exceeded, an alarm is triggered. Two additional relay contacts with selectable switching points are available for external alarm devices, for level control or for connection to telecommunication or building control systems. Easy operation due to device setup via menus. High measuring accuracy due to electronic sensing. Standard tank shapes are stored. Watertight up to 10 m water column.

Technical specifications

Functions

Selection of units, daily saving of level data, consumption monitoring, graphical evaluation of consumption values (up to 5 years), calculation of remaining range, alarm functions (min./max.), sensor error and short circuit alarms.

Measuring range

0/400 mbar

Measuring accuracy

±1.5 % FS

Operating temperature range

Medium: -5/+70 °C
Ambient: 0/45 °C
Storage: -5/+70 °C

Display

High-resolution, backlit graphical display (30 x 50 mm). Indication of either litres (6 digits), m³, % or liquid level in mm. Symbols for alarm functions.

Submersible probe

Housing: Stainless steel 304 (1.4301)
Cable: PVC, 6 m with breather tube
Diaphragm: Stainless steel 316 L (1.4435)
Seals: FKM (Viton)
Spacer: POM, PE
Degree of protection: IP 68 (EN 60529)

Supply voltage

AC 230 V
Lithium battery for data backup (calendar function)

Switching outputs

Relay contacts: 2 voltage-free changeover contacts
Contact rating: AC 230 V, 2 A

Hydrostatic level indicator TankControl 10

Technical specifications

Visual alarm

Red LED

Audible alarm

Integrated piezo buzzer, can be acknowledged

Housing

Wall mounting housing made of impact-resistant plastic (ABS)
W x H x D 100 x 188 x 65 mm
Degree of protection IP 54 (EN 60529)

Scope of delivery

- Control unit with graphical display and 15 m connection cable to the probe (cannot be extended)
- Submersible probe with 6 m submersible cable
- Moisture-proof junction box (IP 54)
- Screw connector kit G1 x G1½ x G2
- Mounting kit for withdrawal flange at plastic battery tanks

Options

- Submersible probe for differential alarm
- Floating probe (spare probe Minimelder)

1

Application examples TankControl 10

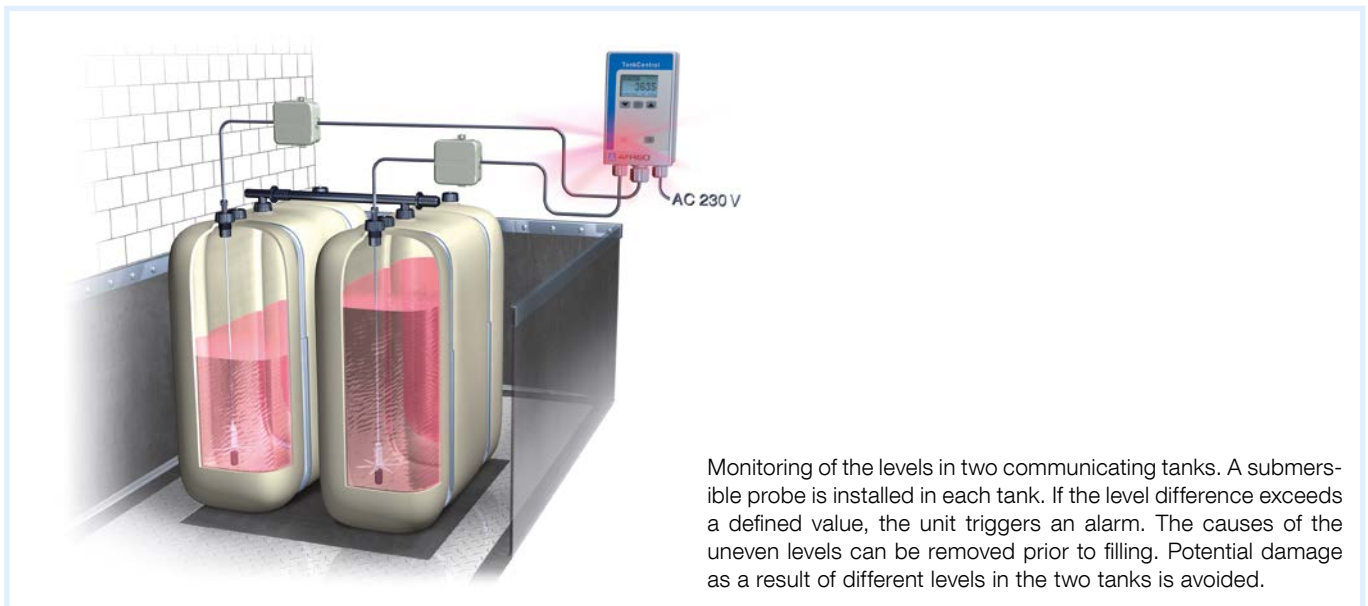

Monitoring of the levels in two communicating tanks. A submersible probe is installed in each tank. If the level difference exceeds a defined value, the unit triggers an alarm. The causes of the uneven levels can be removed prior to filling. Potential damage as a result of different levels in the two tanks is avoided.

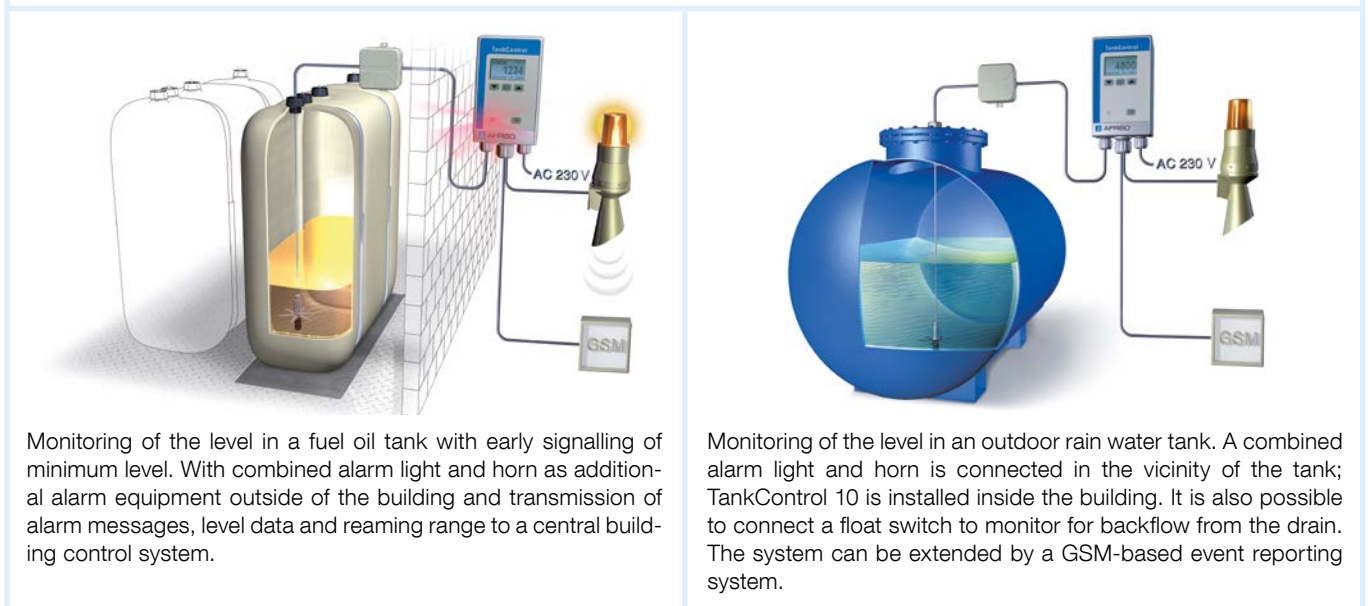

Monitoring of the level in a fuel oil tank with early signalling of minimum level. With combined alarm light and horn as additional alarm equipment outside of the building and transmission of alarm messages, level data and remaining range to a central building control system.

Monitoring of the level in an outdoor rain water tank. A combined alarm light and horn is connected in the vicinity of the tank; TankControl 10 is installed inside the building. It is also possible to connect a float switch to monitor for backflow from the drain. The system can be extended by a GSM-based event reporting system.

PG: 4	DG	Part no.	Price €
TankControl 10	H	52151	
Spare submersible probe (0/400 mbar)	H	52153	
Additional probe differential alarm	H	52152	
Floating probe (spare probe Minimelder)	G	16703	

Hydrostatic level indicator

HydroFox® DMU 08



1



- Compact and sturdy stainless steel design
- Special calibration for all standard pressure units possible
- Version with PUR or FEP cable
- Optional ATEX version



Page 17

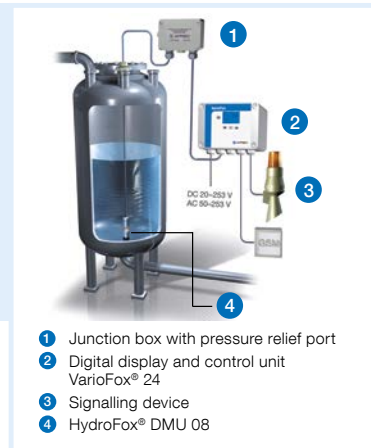

- 1 Junction box with pressure relief port
- 2 Digital display and control unit VarioFox® 24
- 3 Signalling device
- 4 HydroFox® DMU 08

Application For electronic, continuous level measurement, e.g. in wells, drilling holes, water, containers or in waste water systems. Suitable for groundwater, drinking water, waste water (with optional FEP cable), diesel fuel, fuel oil; also for use in flood hazard areas.

Description The level indicators HydroFox® DMU 08 use silicon technology and feature calibrated, amplified sensor signals which are available as standardised voltage or current outputs.

Technical specifications

Measuring accuracy

Deviation from the characteristic curve according to IEC 60770 – limit point calibration (non-linearity, hysteresis, Repeatability): $\lt; \pm 0.5\% \text{ FSO}$

Measuring ranges

Relative pressure: 0/100 mbar bis 0/300 mbar (see catalogue INDUSTRIAL TECHNOLOGY for further measuring ranges)

Overpressure safety

Depends on pressure range
4 x FS to 15 x FS (burst pressure)
3 x FS to 8 x FS (overload)

Operating temperature range

Medium: -10/+70 °C
Ambient: -10/+70 °C
Storage: -25/+70 °C

Temperature error band

in compensated range
0/70 °C $\leq \pm 1\% \text{ FSO}/10 \text{ K}$

Dynamic characteristics

Response time $\leq 10 \text{ ms}$

Materials

Housing: Stainless steel 316 L
Diaphragm: Stainless steel 316 L
Seals: FKM (Viton)
Cable: PUR cable

Pressure transmission liquid

Silicone oil

Supply voltage

DC 12–36 V

Output signal

4–20 mA, 2-wire

Load

4–20 mA: $R_{\text{max}} = [(U_B - U_{\text{Bmin}})/0.02 \text{ A}] \Omega$

Current input

4–20 mA $\lt; 25 \text{ mA}$

Electrical protection

Short circuit proof and protected against reverse polarity

Electrical connection (degree of protection)

PUR cable (IP 68)
With integrated breather tube for reference to the ambient atmospheric pressure

Options

- Extended weight
- Measuring accuracy 0.1 % FSO
- FEP cable
- ATEX version

Accessories

- Screw connector kit
- Junction box
- Anchor clamp

DG: H	PG	Part no.	Price €
DMU 08 with 5 m PUR cable			
Measuring range			
0/100 mbar	4	31555	
0/160 mbar	4	31556	
0/200 mbar	4	31557	
0/250 mbar	4	31558	
0/300 mbar	4	31519	
Screw connector kit plastic, G2 x 1½ x 1	1	52125	
Junction box with pressure relief port	1	31824	
Anchor clamp	3	31825	

i

Complete range of "pressure transducers" see catalogue INDUSTRIAL TECHNOLOGY.

Digital display units DA 10/12/14



- Grey display with excellent readability
- Text-based user interface
- Linearisation for volume indication (24 points)
- Scalable units, displayed as bar chart
- Integrated supply voltage for transducer



Page 86



- 1 Digital display unit DA 12
- 2 Signalling device
- 3 Pressure transducer DMU 07

Application Universal application for electronic transducers for displaying measured values (DA 10), optionally with additional relay outputs (DA 12/14) for electronic transducers.

Description Digital display unit in plastic housing for control panel mounting. With grey display and automatic off function for the backlight. The universal measurement input can be configured as a current input or a voltage input. Standard bearing charts for cylindrical horizontal tanks and spherical tanks are pre-programmed, additional units can be selected or set up. The units are scalable and shown as bar charts. Limit values can be displayed via a window and a trend function (rising/falling). With display message (flashing error text) if values are exceeded, parameter backup for restoring previous configurations and potentiometer for test purposes.

Technical specifications

Display

5-digit graphical LC display, backlit (white), text-based user interface, user interface language selectable (German, English, French, Italian), selectable units, custom units can be defined

Measuring range

± 99,999 digits (start and end values scalable as required)

Linearity

± 0.1 % of measuring range

Resolution

Decimal point position can be set as required

Response time

< 0.2 s

Operating temperature range

Ambient: 0/50 °C

Supply voltage

AC 50–253 V / DC 20–253 V
DC 2.5 W / AC 4.4 VA

Sensor supply

Integrated, galvanically isolated supply voltage for transducer: 17 VDC at 20 mA

Sensor input

All analogue standard signals, e.g. 4–20 mA, 0–20 mA, 0–1 V, 0–10 V as well as potentiometer

Analogue output

0/4–20 mA, galvanically isolated

Housing

Standard rack mounting housing
W x H x D: 96 x 48 x 135 mm

Panel cut out

W x H: 92 x 45 mm

Degree of protection (front)

IP 65 (EN 60529)

Electrical connection

Screw terminals, pluggable (1.5 mm²)

Linearisation

Customer-specific linearisation with a max. of 24 points for the indication of volume (e.g. litres) in non-linear tanks. Bearing charts for cylindrical horizontal tanks and spherical tanks are pre-programmed.

Min./max. memory

The highest and lowest values reached during operation can be displayed.

Additional functions DA 12 / 14

Analogue output 2

0–10 V, galvanically isolated

Switching outputs

Relay contacts: 2 x (DA 12) / 4 x (DA 14)
voltage-free changeover contacts (adjustable switching hysteresis)
Contact rating: AC 250 V, 2A, 100 VA

DG: H, PG: 4	Part no.	Price €
DA 10	31281	
DA 12	31282	
DA 14	31283	
DG: H, PG: 3		
Wall mounting housing WAG 01 for mounting of one DA	31287	
WAG 02 for mounting of two DAs	31288	
WAG 03 for mounting of three DAs	31289	
WAG 04 for mounting of four DAs	31290	



See the catalogue INDUSTRIAL TECHNOLOGY for the complete range of "Digital Display Units".

Digital display and control unit VarioFox® 24

1



- Can be used as compact, ready-to-connect filling or emptying controller
- Visual and audible alarms
- 4 switching outputs
- Data logger function via SD memory card or RS485 interface

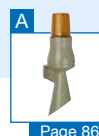

Page 86

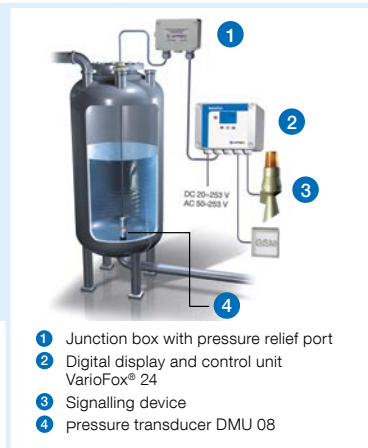

- 1 Junction box with pressure relief port
- 2 Digital display and control unit VarioFox® 24
- 3 Signalling device
- 4 pressure transducer DMU 08

Application Universal application for indication of measured values and for control systems. Can also be used as a data logger in conjunction with an SD card.

Description Compact, ready-to-connect display and control unit in a robust wall-mounting housing. With integrated sensor supply and 4 relay outputs. Together with a transducer (e.g. for pressure, temperature, level, etc.), VarioFox® forms an autonomous measuring and control system. VarioFox® is universally applicable and freely configurable.

Technical specifications

Display

Multi-coloured, backlit graphical display (50 x 30 mm)

- Blue = Operation
- Red = Alarm
- Green = Setup

Display (5 digits)

User interface language selectable:

English, German, French, Italian (start and end values as well as comma scalable as required)

Linearity

±0.1 % of measuring range

Resolution

10 bits, decimal point position can be set as required

Response time

< 0.2 s, filter can be activated

Operating temperature range

Ambient: 0/50 °C

Storage: -20/+65 °C

Supply voltage

AC 50–253 V, 4.2 VA

DC 20–253 V, 2.7 W

Sensor supply

Integrated, galvanically isolated power supply for transducer: DC 20 V/20 mA

Analogue input

All analogue standard signals, e.g. 4–20 mA, 0–20 mA, 0–10 V

Audible alarm

Integrated piezo buzzer, can be acknowledged

Analogue output 1

0/4–20 mA, galvanically isolated

Analogue output 2

0–10 V, galvanically isolated

Digital interface

RS485 (19200 Baud)
with Baud rate adjustment

Switching outputs

Relay contacts: 4 voltage-free changeover contacts (adjustable switching hysteresis)

Contact rating: AC 250 V 2 A 250 VA
DC 250 V 1 A 100 W

Housing

Robust wall mounting housing made of impact-resistant plastic (PC)

W x H x D: 175 x 125 x 75 mm

Degree of protection: IP 65 (EN 60529)

Colour: RAL 7035 (grey)

Electrical connection:

5 x cable gland M16 x 1.5 mm

Linearisation

Customer-specific linearisation with a max. of 24 points for the indication of volume (e.g. litres) in non-linear tanks. Bearing charts for cylindrical horizontal tanks and spherical tanks are pre-programmed.

Min./max. memory

The highest and lowest values reached during operation can be displayed.

Data storage and clock

Long-term monitoring data is stored on a memory card (SD/MMC). Memory card not included.

DG: H, PG: 4	Part no.	Price €
VarioFox® 24 (4 relay contacts)	31248	
SD memory card 1 GB, industrial version	31257	

Level switches

Minimelder-R and Maximelder-R



- For fuel oil EL, L, M, oil/water mixtures and many other media
- With visual/audible alarms, Acknowledge button and 1 relay
- Wall mounting housing for fast, professional mounting
- EnOcean®-ready

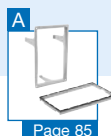

Page 85

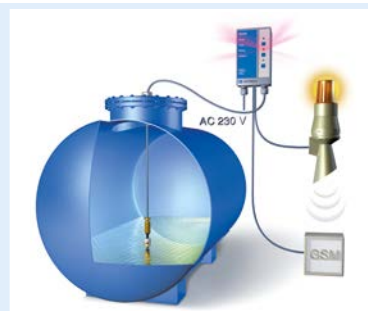

1

Application Designed to signal minimum or maximum levels of water, heating oil EL, L, M, oil/water mixtures and neutral, non-viscous and non-adhesive liquids in tanks. System owners are alerted when the supply runs low or if there is a hazard of overfilling.

Description Minimelder/Maximelder consist of a control unit and a height-adjustable float probe. The Minimelder probe is mounted in the bottom area of the tank and generates an alarm signal when the liquid level falls and the probe is no longer submerged in the liquid. The Maximelder probe is mounted in the top area of the tank and generates an alarm when the liquid reaches the probe. The liquid levels are adjustable. When these levels are reached, the units generate visual and audible alarms. The integrated relay can be used for transmission of the signal to external alarm equipment or for connection to telecommunication or building control systems. Alarm units with the EnOcean-ready label can be integrated into your existing building automation systems at a later point in time. To do so, plug the EnOcean® wireless module TCM 320 into the EnOcean® interface (PCB of the device). The AFRISO gateway in conjunction with additional AFRISO products with EnOcean® wireless technology allow you to configure a whole range of fully customisable, extensible features for the protection of plants and buildings.

Technical specifications

Operating temperature range

Medium: -5/+50 °C

Ambient: -5/+55 °C

Process connection

Plastic screw fitting G1, with cable gland for height adjustment

Probe

Magnetic float switch

L x Ø: 85 x 25.2 mm

Float: Plastic (PA/PP)

Cable: 5 m oil-resistant cable 2 x 0.5 mm²

Weight: Brass

Degree of protection: IP 68 (EN 60529)

Probe voltage: Max. 17 VAC

Connection probe – control unit

Length: 5 m (optionally up to 50 m)

Supply voltage (control unit)

AC 230 V

Power input

5 VA

Switching output

Relay contact: 1 voltage-free changeover contact

Contact rating: AC 250 V, 2 A

Visual indication

1 green LED (operation)

1 red LED (alarm)

Audible alarm

Integrated piezo buzzer, can be acknowledged

Function test



By means of Test button

Housing

Wall mounting housing made of impact-resistant plastic (ABS)

W x H x D: 100 x 188 x 65 mm

Degree of protection: IP 30 (EN 60529)

DG: G, PG: 4			Part no.	Price €
Minimelder-R	1	-	16701	
Maximelder-R	1	-	16702	
Spare probe for Minimelder	1	-	16703	
Spare probe for Minimelder, 50 m	1	-	16719	
Spare probe for Maximelder	1	-	16704	
Accessories (DG: G, PG: 1)				
Mounting frame	1	-	43521	
Sealing kit (IP 54)	1	-	43416	
EnOcean® wireless module TCM 320	1	-	78082	

CATALOGUE INDUSTRIAL TECHNOLOGY

Product solutions for industrial level applications



SonarFox® UST 20

- + Ultrasonic transmitter for non-contact level measurement of liquid and solid media
- + Integrated flow calculation with 32-point linearisation

Measuring ranges
0.15 – 2 m, 0.25 – 6 m, 0.4 – 10 m, 0.5 – 20 m

Measuring accuracy
0.25 %

Page 308

NEW



PulsFox® PMG 20

- + Guided micropulse: Level measurement independent of dielectric constant ϵ_r or changes in pressure, temperature or density
- + Reliable, accurate measurement even with foam, vapour, dust or turbulent surfaces of the medium
- + Available as mono probe or coax probe version

Measuring range
up to $\leq 40,000$ mm

Page 312

NEW



CapFox® EFT 20

- + Capacitance level measurement for fuel oil, diesel fuel and many other liquids as well as bulk solids
- + Rod probe and flexible probe versions

Measuring range
0/100 mm to 0/6,000 mm

Measuring accuracy
 ± 1 % FS

Page 303

NEW

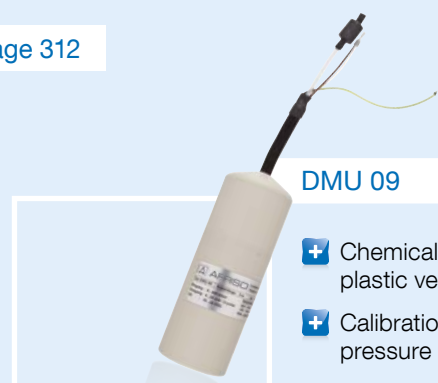

DMU 09

- + Chemical-resistant plastic version
- + Calibration for all standard pressure units possible

Measuring ranges, relative pressure
0/40 mbar to 0/10 bar

Measuring accuracy
 $< \pm 0.35$ % FSO

Page 229

i
This and many other products can be found in the catalogue INDUSTRIAL TECHNOLOGY.



Overfill prevention systems



Level sensors



Accessories

CHAPTER 2

Level sensors, overflow prevention systems and PTC thermistor type level controllers

OVERVIEW

Level sensors/overflow prevention systems at a glance	24
Level sensor chain GWG chain	26
Level sensors with metallised sleeve	29

LEVEL SENSORS

Universal withdrawing system with level sensor chain	28
Level sensors for indoor tanks GWG 12	30
GWG filler caps, cable extension fitting KVA and reducers	32
Level sensors for outdoor tanks GWG 23-Ro/T	34
Level sensors for outdoor tanks GWG 23-Wa	35
Level sensor tester GPG 01	37
Level sensor tester GPR 4	38
Level sensor tester ME 6 / ME 6 P	38

OVERFLOW PREVENTION SYSTEMS

Transducers UFS 01	39
Transducer NB 220 H	40
Level probe type 76 A , type 76 AH	41
Transducer LS 500 , level probe LS 300 EU	42

LEVEL CONTROLLERS

Level controllers RG 210	43
------------------------------------------	----

Level sensors/overflow prevention systems at a glance

2



GWG 12 K/1

GWG 12 K/1C

GWG 12 K/MT

GWG 23-Ro

Level sensors

	GWG 12 K/1	GWG 12 K/1C	GWG 12 K/MT	GWG 23-Ro
Rectangular tanks (DIN 6625-1)	•	•	•	•
Cylindrical horizontal steel tanks (EN 12285-1, 12285-2, DIN 6624-1, 6608-2)				•
Cylindrical vertical steel tanks (DIN 6618-1)				•
Cylindrical vertical steel tanks (DIN 6619-1)				•
Cylindrical vertical steel tanks (DIN 6623-1)				•
Flat bottom tanks (DIN 4119-1)				
Plastic tanks	•	•	•	•
Other tank types*	•	•	•	•
Fuel oil EL (DIN 51603-1)	•	•	•	•
Diesel fuel (EN 590)	•	•	•	•
Fuel oil EL (DIN 51603-1) with 20 % fatty acid methyl ester (FAME) as biofuel	•	•	•	•
Fuel oil EL (DIN 51603-1) with 100 % fatty acid methyl ester (FAME) as biofuel	•		•	•
Diesel fuel (EN 590) with 20 % fatty acid methyl ester (FAME) as biodiesel	•	•	•	•
Diesel fuel (EN 590) with 100 % fatty acid methyl ester (FAME) as biodiesel	•		•	•
Petrol (EN 228)				•**
Aviation petrol				
Aviation / Gasoline				
Aviation turbine fuels				
Special grade fuels				
Aliphatic hydrocarbons				
Gearbox oils, motor oils and hydraulic oils				
Transformer oil				
Vegetable oils				
Oil/water mixtures				
Antifreeze agents				
AdBlue®				
Other flammable/non-flammable liquids*				
Approval: German Institute for Civil Engineering (DIBt)				
Approval: CE as per EU Construction Products Regulation, EN 13616:2004	•	•	•	•
ATEX type examination certificate				•**

Tanks

Media

Approvals

🏠 Page 30

🏠 Page 31

🏠 Page 31

🏠 Page 34

* See the product description on the corresponding catalogue page or the operating instructions for suitability for other tanks/media.

** Depending on product version.

Level sensor chain



Is the battery tank facility protected against overflow damage?

2

Level differences at the beginning of or during the filling process are not an uncommon phenomenon; there are various reasons for this. If this effect occurs, the causes must be identified and removed as quickly as possible. Possible causes include an insufficient flow rate during filling, pollution in the filling or withdrawal systems or leaks. When conventional tank facilities are filled and the

first tank filled is not equipped with a level sensor, there is a high risk of overflowing and fuel oil spills. Possible fatal consequences: damage to the building, soil contamination, environmental damage (groundwater), long-term odour problems and immense consequential costs. The owner or operator is fully responsible for all damages.

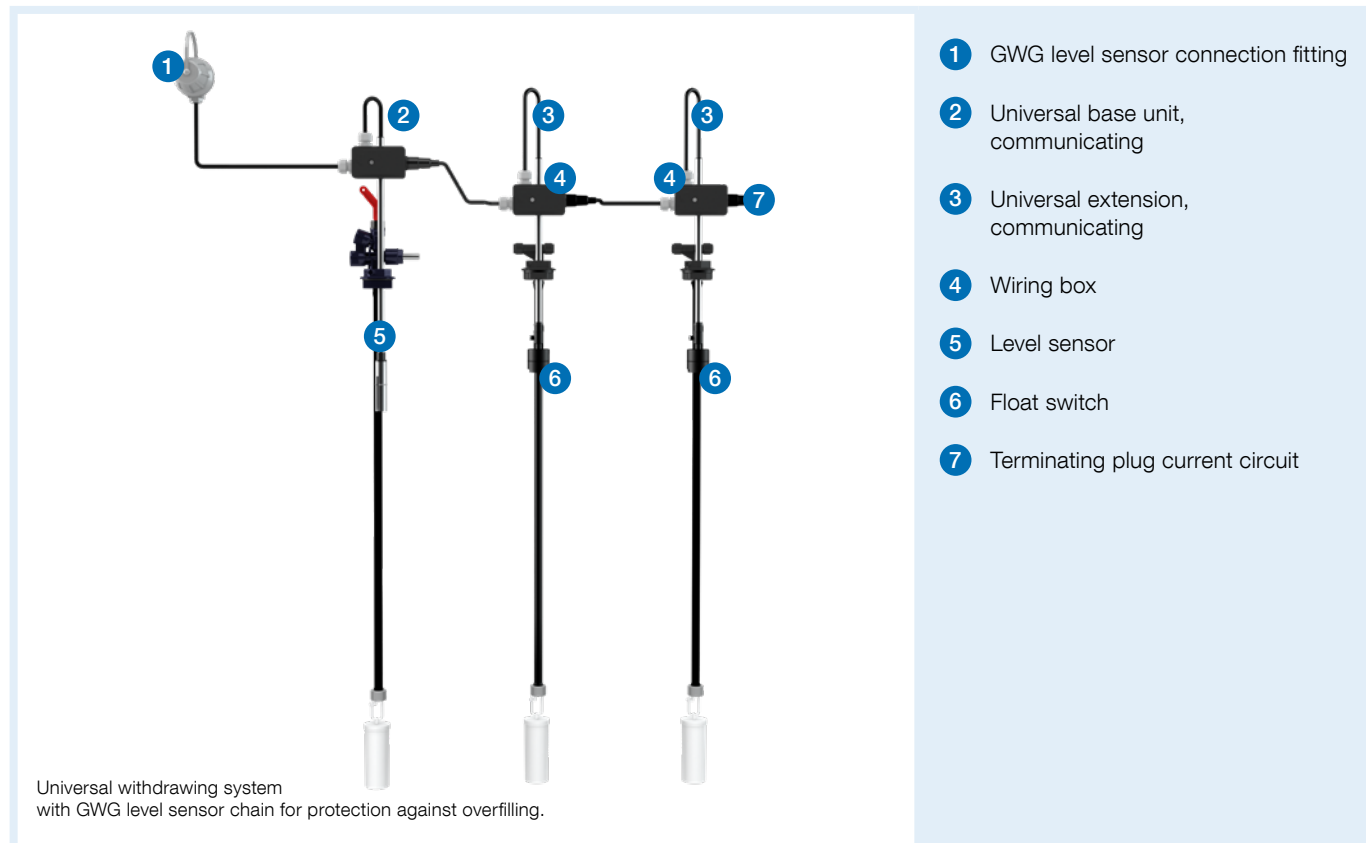

Function principle of GWG level sensor chain

The current circuit of the level sensor which is supplied from the tank vehicle during the filling process and which serves as a safety shut-off system includes float switches if the GWG level sensor chain is installed. A terminating plug at the last tank closes the current circuit. During normal filling, the filling process is terminated when the level sensor is submerged. However, if a tank of the facility without a level sensor reaches its maximum level first, the float

switch stops the filling process just as if the level sensor had responded. The additional volume caused by the shut off delay and the content of the filling line is considered. Since the filling level of all tanks must be visually detectable or indicated by means of a level indicator, the tank that has caused the shut off is easy to identify.

Level sensor chain



GWG level sensor chain – the best protection against damage caused by overfilling

The AFRISO GWG level sensor chain is used to protect battery tank facilities against overfilling. The system is available for communicating and non-communicating tank facilities. The first tank – in direction of filling – is equipped with the level sensor officially required (system with filling from the top). With the GWG level sen-

sor chain, each additional tank of the facility contains a float switch to limit the filling level; this level switch is connected to the wiring box of the first level sensor by means of pre-assembled cables and connectors. A terminating plug is connected at the last tank.

2

Universal withdrawal system with GWG level sensor chain in non-communicating system for three battery tanks with level sensor, level limiters and floating withdrawal. Available for retrofitting of existing systems and for new systems of virtually all well-known tank manufacturers.



Picture: DEHOUST GmbH

Application example with Dehoust tanks: GWG level sensor chain as top filling system DE-A-01 with combined filling and vent line, withdrawal line, level sensor, level limiters and floating withdrawal.

Universal withdrawing system with level sensor chain



2

Extension, communicating

Base unit, communicating

- Complete withdrawal system with level sensor chain
- Universal replacement for withdrawal systems of battery tank facilities
- Reliable protection against overflowing by means of monitoring of all tanks
- Level sensor with metallised sleeve for permanent operation even with biofuel/biodiesel



Adapters for various tank connections

Application Replacement for withdrawal system at battery tank facilities of almost all manufacturers. Depending on the version, available for communicating and non-communicating systems. One base unit per system and one extension for each additional tank. The level sensor chain is completely integrated.

Description The base unit with the level sensor is mounted in the first tank (viewing in direction of filling). An extension is mounted in each additional tank of the battery tank facility. This applies to regular filling from the top. The level sensor and the level limiters are fully wired, the cables just need to be plugged in. The connector shipped with the base unit is plugged into the last extension. This closes the circuit. The connection cable to the level sensor fitting is connected in the junction box. The pipes for the withdrawal line can be connected with a diameter of 8 mm or 10 mm. The connection pipes for the withdrawal line are not included. Adapters for the tank connections of tanks of virtually all manufacturers are included.

Technical specifications

Tank height

Up to 200 cm, can be shortened as required

Connection thread (tank)

G1½

Enclosed adapters for tank connections: G2, M60 x 4, S75 x 6, flange Ø 68 mm

Media

Fuel oil (DIN 51603-1)

Diesel fuel (EN 590)

with up to 20 % FAME each

Approval



GWG: CE as per EU Construction Products

Regulation (EN 13616:2004)

GWG chain, level limiter: Z-65.17-182 (DIBt)

Scope of delivery

- **Base unit:** Floating withdrawal unit, wiring box, terminating connector, level sensor, adapters for tank connection
- **Extension:** Floating withdrawal unit, wiring box, float switch, connection cable, adapters for tank connection

DG: G, PG: 3			Part no.	Price €
Universal base unit, communicating, level sensor chain	-	-	20820	
Universal extension, communicating, level sensor chain	-	-	20824	
Universal base unit, not communicating, level sensor chain	-	-	20825	
Universal extension, not communicating, level sensor chain	-	-	20826	
Withdrawal unit multi-way union Ø 8/10 mm	1	10	20842	
Withdrawal pipe universal Ø 10 x 1 x 1,000 mm, aluminium	10	-	20843	

i

See operating instructions for list of suitable tanks and tank connections.

Level sensor with metallised sleeve



With the GWG level sensors and the metallised sleeve, AFRISO offers maximum safety for the filling of tank facilities. In the case of conventional level sensors, a plastic sleeve provides mechanical protection of the PTC thermistor. The sleeve is open at the bottom and has a slot at the side so that the fuel oil can easily reach the PTC thermistor. However, the openings of the sleeve may get clogged due to the growth of microorganisms (such as bacteria and fungi) and an air cushion prevents the fuel oil from reaching the PTC thermistor. The rise in the use of biofuel with a certain percentage of FAME (fatty acid methyl ester) increases this risk. The higher the FAME content, the greater the water content in the fuel can be. This creates an environment even more susceptible to the growth of microorganisms. This may cause the level sensor to malfunction and ultimately disable the safety shut-off system. This may lead to overflow damage for which the owner/operator of the facility is liable.



Permanently reliable.

The metallised surface of the new sleeves and the new shape of the slot help to prevent the growth of microorganisms and improve the long-term reliability of the level sensor.

Level sensor GWG with metallised or stainless steel sleeve

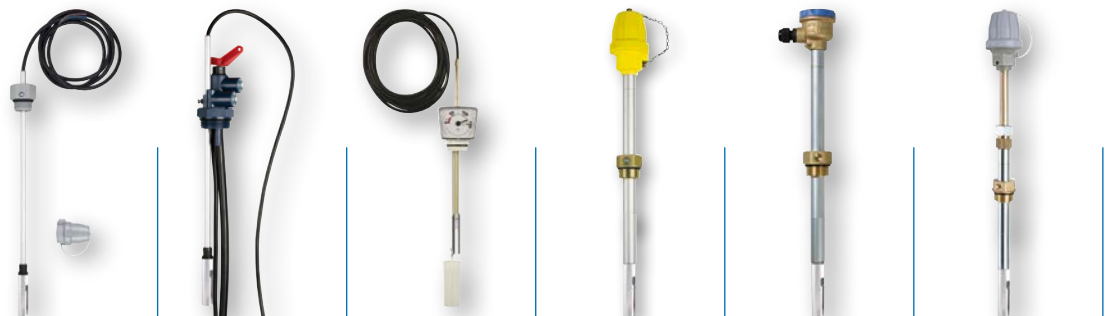

Type	GWG 12 K/1	GWG 12 K/1C	GWG 12 K/MT	GWG 23-RO	GWG 23-WA	GWG 23-T
Application	For indoor tanks or plastic tanks, also battery tank systems.			For all indoor or outdoor tanks (aboveground or underground), except for battery tank systems.		
Media	Fuel oil EL (DIN 51603), diesel fuel (EN 590), FAME 100 % (EN 14214) as biofuel or biodiesel (up to 20 % FAME with GWG 12 K/1C)					
Approval	CE marking as per EC Construction Products Regulation 305/2011, EU 574/2014 (EN 13616:2004)					

Level sensors for indoor tanks



2



GWG 12 K/1

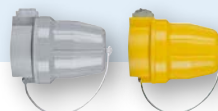

- Design as per EN 13616
- Metallised sleeve for permanent operation even with biopetroleum/biodiesel
- Universal use due to variable height adjustment
- Impact-resistant, shock-resistant and deformation-resistant GWG level sensor connection fitting (type 905 yellow)
- The right version for each application



GWG 12 K/1 with bracket

Application To be used as part of an overflow alarm system to avoid overflowing of tanks. For battery tank systems, rectangular tanks welded on site and other indoor tanks. Suitable for use in flood hazard areas.

Description PTC thermistor type level sensor consisting of probe, screw fitting, fitting for wall mounting as well as cable between probe and fitting. Watertight up to 10 m water column. Odour-tight. Metallised sleeve. The GWG level sensor connection fitting type 905 yellow is shock-resistant, impact-resistant and deformation-resistant. GWG 12 K/1 (bracket) with pre-mounted connection fitting type 905 made of grey plastic. The connection fitting is fixed to an aluminium bracket. The connection cable of the level sensor is factory-wired to the connection fitting. For tanks with direct filling (without filling pipe from the outside). See the ordering table for the available versions, fitting colours, probe and cable lengths. GWG filler cap type 906 (part no. 20430) can also be used.

Technical specifications

Process connection
Screw fitting G1, plastic

Media

- Fuel oil EL (DIN 51603-1)
- Diesel fuel (EN 590)
- FAME 100 % as biofuel
- FAME 100 % as biodiesel

Adjustment range

Probe length 360 mm: 80 to 338 mm
Probe length 480 mm: 80 to 438 mm

Approval

CE marking as per EU Construction Products Regulation 305/2011, EU 574/2014, EN 13616:2004

DG: G, PG: 3	Probe length	Fitting	Cable length			Part no.	Price €
GWG 12 K/1 yellow	360 mm	Yellow	1.5 m	1	25	45100	
GWG 12 K/1 grey	360 mm	Grey	1.5 m	1	25	45105	
GWG 12 K/1 grey	480 mm	Grey	1.6 m	1	25	45102	
GWG 12 K/1/5 yellow	360 mm	Yellow	5.0 m	1	15	45160	
GWG 12 K/1/5 grey	360 mm	Grey	5.0 m	1	15	45165	
GWG 12 K/1	360 mm	Without	1.5 m	1	25	45166	
GWG 12 K/1	360 mm	Without	5.0 m	1	20	45167	
GWG 12 K/1 with bracket	360 mm	Grey	0.4 m	1	25	45104	
GWG 12 K/1/5	As desired	Grey	5.0 m	1	-	45199	

Level sensor combinations



2

Application To be used as part of an overfill alarm system to avoid overfilling of tanks. For battery tank systems, rectangular tanks welded on site and other indoor tanks. Suitable for use in flood hazard areas.

GWG 12 K/1C (Euroflex 312)

Description **Combination fitting exclusively for individual tanks.** PTC thermistor type level sensor consisting of probe, screw fitting, fitting for wall mounting as well as cable between probe and fitting. Watertight up to 10 m water column. Odour-tight. Metallised sleeve. The screw fitting is a withdrawal system Euroflex 312 with quick-action shut-off valve with connection for flow, return and measuring lines. The GWG level sensor connection fitting type 905 yellow is shock-resistant, impact-resistant and deformation-resistant.

Technical specifications

Fitting
Type 905 yellow for wall mounting

Process connection
Screw fitting G1½

Medium

- Fuel oil EL (DIN 51603-1)
- Diesel fuel (EN 590)
- FAME 20 % in fuel oil
- FAME 20 % in biodiesel

Adjustment range
80 to 338 mm

Probe length
360 mm

Hose length
2.15 m

Cable length
5 m

Approval
CE marking as per EU Construction Products Regulation 305/2011, EU 574/2014, EN 13616:2004

GWG 12 K/MT

PTC thermistor type level sensor consisting of mechanical level indicator MT-Profil R, probe, screw fitting, fitting for wall mounting as well as cable between probe and fitting. Watertight up to 10 m water column. Odour-tight. Metallised sleeve. The GWG level sensor connection fitting type 905 yellow is shock-resistant, impact-resistant and deformation-resistant.

Fitting
Type 905 yellow for wall mounting

Process connection
Screw fitting G1½

Medium

- Fuel oil EL (DIN 51603-1)
- Diesel fuel (EN 590)
- FAME 100 % in biofuel
- FAME 100 % in biodiesel

Measuring range level (tank height)
Reversible scale 0/150 cm and 0/250 cm

Adjustment range level sensor
80 to 338 mm

Probe length
360 mm

Cable length
5 m

Approval
CE marking as per EU Construction Products Regulation 305/2011, EU 574/2014, EN 13616:2004



GWG filler cap see page 32.

DG: G	PG			Part no.	Price €
GWG 12 K/1 C with withdrawal system Euroflex	1	1	10	20190	
GWG 12 K/MT with level indicator MT-Profil R	3	1	10	45311	

Accessories for level sensors

2

GWG filler cap

Application For facilities that are operated with fuel oil EL or biofuel, diesel or biodiesel.
Suitable for flood hazard areas.

Description GWG filler cap with bayonet connection G2 with integrated level sensor connection fitting. Brass male coupling as per EN 14420-6. Filler cap made of oil- and weather-resistant plastic. Watertight up to 10 m water column. Lockable with standard padlock.



GWG filler cap

Cable extension fitting KVA

Application For 2-wire electrical cables (max. 42 V/4 A).
Suitable for flood hazard areas.

Description Clamp connections (gland) at both ends for cable diameters between 6 and 8.3 mm. Watertight up to 10 m water column.

Wire cross section: Max. 2.5 mm²
Degree of protection IP 68 (EN 60529)

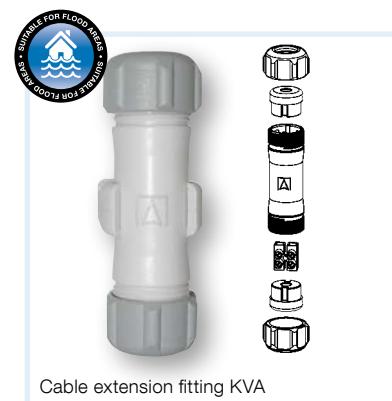

Cable extension fitting KVA

Reducers

Reducer G1½ x G1

Reducer G1½ x G1 made of grey plastic (ABS).

Reducer G2 x G1½

Reducer G2 x G1½ made of grey plastic (ABS).



Reducers

See page 127 for additional filler caps.
See page 37 for level sensor testers.
See page 36 for fittings for level sensors.

DG: G	PG			Part no.	Price €
GWG filler cap	2	1	10	20430	
Reducer G1½ x G1	1	10	-	20905	
Reducer G2 x G1½	1	10	-	20903	
Cable extension fitting KVA	1	1	10	40041	

Level sensors for outdoor tanks as per EN 13616:2004



Fittings for level sensors

- 1 Coupling plug type 902
- 2 Coupling socket type 903
- 3 GWG level sensor fitting for wall mounting type 905
- 4 Pipe fitting type 904 with flange plug type 901

Benefits

- The right version for each application
- Compact, corrosion-proof design
- Adjustable for different tank sizes
- Universal use due to variable height adjustment
- Yellow tube fitting made of impact-resistant plastic with ATEX approval (zone 0) and stainless steel sleeve
- Chemical resistance even if used with biodiesel, biofuel or admixtures up to 100 %
- Metallised sleeve of grey fitting for permanent operation even with biofuel/biodiesel
- Easy and fast installation

Level sensor GWG 23-Ro/T for outdoor tanks as per EN 13616:2004



2

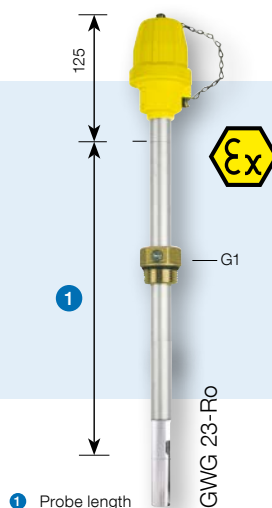

1 Probe length

- For fuel oil EL, diesel fuel, biofuel/biodiesel and petrol
- With metallised sleeve (with grey version) for permanent operation even with biofuel/biodiesel
- Yellow fitting with ATEX type examination certificate (zone 0) and stainless steel sleeve
- Variable height adjustment

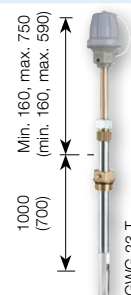

Application Part of a control chain for overfill alarm systems. The level sensor helps to prevent overfilling of tanks. For tanks as per EN 12285-1, 12285-2, DIN 6618, 6619, 6623, 6624, 6608, 4119 and tanks as per DIN 6620 and DIN 6625 or equivalent tanks. Suitable for the following media: fuel oil EL and diesel fuel as well as biofuel, biodiesel or petrol under certain conditions. See the operating instructions for additional information.

Description PTC thermistor type level sensor consisting of height-adjustable probe and screw fitting. Pressure- and vacuum-tight. Watertight up to 10 m water column.

GWG 23-Ro with tube fitting made of **yellow plastic**, highly impact-resistant, deformation-resistant, with strong chain and flange gasket. Also suitable for petrol with **GWG level sensor sleeve made of stainless steel**.

GWG 23-Ro with tube fitting made of **grey plastic**. Suitable for the following media: fuel oil, diesel fuel, biofuel and biodiesel. **With metallised sleeve**.

GWG 23-T with telescopic tube for height adjustment of the connection fitting. Tube fitting made **grey plastic**, shock-resistant, with tie, without flange gasket. **With metallised sleeve**.

When selecting a level sensor, please check to see that the fitting is as close as possible below the access chamber cover – the distance should be no less than 20 mm and no more than 300 mm. See the operating instructions for the adjustment dimension in the tank.

Technical specifications

Probe length
From 400 to 1,000 mm, probe lengths up to 3,000 mm, see ordering table

Process connection
Screw fitting G1

Operating temperature range
Medium: -25/+50 °C
Ambient: -25/+60 °C

Operating pressure in the tank
No pressure

Material

GWG level sensor fitting: Plastic
Probe tube: Steel, galvanised
Screw fitting: Brass
PTC thermistor: Glass-encapsulated
GWG sleeve: Plastic, metallised (grey version)
stainless steel (yellow version)

Approval

CE marking as per EU Construction Products Regulation 305/2011, EU 574/2014, EN 13616:2004
GWG with yellow fitting: Ex II 1 G Ex ia IIB T3

i

See page 36 for prices and versions.

Level sensors GWG 23-Wa for outdoor tanks as per EN 13616:2004

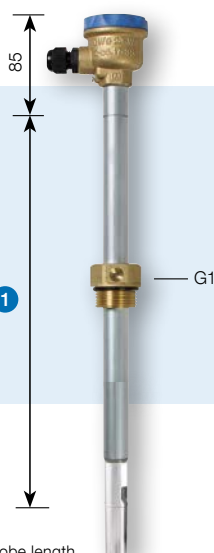

- Fitting for wall mounting
- For fuel oil, diesel fuel, biofuel/biodiesel
- Yellow fitting with ATEX (EC Type Examination Certificate, zone 0)
- Variable height adjustment
- Suitable for use in flood hazard areas
- Yellow fitting with high-grade stainless steel sleeve



GWG level sensor fitting for wall mounting

2

1 Probe length

Application Part of a control chain for overflow alarm systems. The level sensor helps to prevent overfilling of tanks. For tanks as per EN 12285-1, 12285-2, DIN 6618, 6619, 6623, 6624, 6608, 4119 and tanks as per DIN 6620 and DIN 6625 or equivalent tanks whose diameters and volumes correspond to the EN 12285-1 design. Suitable for the following media: fuel oil EL and diesel fuel as well as biofuel, biodiesel or petrol under certain conditions.

See the operating instructions for additional information.

Description PTC thermistor type level sensor consisting of height-adjustable probe, screw fitting, junction box at the upper end of the tube and fitting for wall mounting. Pressure- and vacuum-tight. Watertight up to 10 m water column.

Technical specifications

Probe length

From 400 to 700 mm, probe lengths up to 3,000 mm possible, see ordering table

Process connection

Screw fitting G1

Operating temperature range

Medium: -25/+50 °C

Ambient: -25/+60 °C

Operating pressure in the tank

No pressure

Material

Junction box: Brass/plastic

GWG level sensor fitting (wall mounting): Plastic

Probe tube: Steel, galvanised

Screw fitting: Brass

PTC thermistor: Glass-encapsulated

GWG sleeve: Stainless steel

Approval

CE marking as per EU Construction Products Regulation 305/2011,

EU 574/2014, EN 13616:2004

GWG with yellow fitting: Ex II 1 G Ex ia IIB T3





See page 36 for prices and versions.

Level sensors for outdoor tanks as per EN 13616:2004

	Fitting	Probe length (mm)			DG	PG			Part no.	Price €
GWG 23-Ro 400	Yellow	400			G	3	1	-	46115	
GWG 23-Ro 700	Yellow	700			G	3	1	-	46116	
GWG 23-Ro 1000	Yellow	1,000			G	3	1	-	46117	
GWG 23-Ro So, special lengths	Yellow	Max. 3,000			G	3	1	-	46118	
GWG 23-Ro 400	Grey	400			G	3	1	-	46125	
GWG 23-Ro 500	Grey	500			G	3	1	-	46185	
GWG 23-Ro 700	Grey	700			G	3	1	-	46126	
GWG 23-Ro 1000	Grey	1,000			G	3	1	-	46127	
GWG 23-Wa 400	Yellow	400			G	3	1	-	46130	
GWG 23-Wa 700	Yellow	700			G	3	1	-	46131	
GWG 23-Wa So, special lengths	Yellow	Up to max. 3,000			G	3	1	-	46133	
GWG 23-T 700	Grey	700	Min. length: 860	Max. length: 1,290	G	3	1	-	47622	
GWG 23-T 1000	Grey	1000	1,160	1,750	G	3	1	-	47623	

Please enquire for coded plug inserts for QSS and filling hose control system (ASS).

Accessories	Fitting	DG	PG			Part no.	Price €
GWG level sensor fitting 905-W	Grey	G	1	1	-	40050	
GWG level sensor fitting 905-W	Yellow	G	1	1	-	40052	
Coupling socket TW 903	-	G	1	1	-	40030	
Coupling plug TW 902	-	G	1	1	-	40045	

Level sensor tester GPG 01



- Intuitive operation by means of step by step instructions
- For all level sensors as per EN 13616:2004 design B1 or TRbF 511
- For liquids with a flash point of > 55 °C such as fuel oil, diesel and other liquid fuels or oils
- High-resolution TFT colour display and powerful lithium-ion battery for optimum readings and many measurements
- Robust protective sleeve with magnet for convenient, hands-free operation

2

Application For full testing of level sensors which are not used in hazardous areas/potentially explosive atmospheres. It is possible to perform a simple electrical function test with the level sensor installed as well as a wet test with the level sensor uninstalled.

Description Modern, robust housing with high-resolution TFT colour display and foil keypad with four keys and On/Off button. A 1.2 m connection cable with a coupling socket 903 for plugging in the level sensor is mounted at the top. A mini USB port for the power supply unit/battery charger is located at the bottom. The electrical function test displays the heat-up time in seconds and filling release. When a wet test is performed, the switch off time in seconds after submersion in liquid is indicated. At the end of the test, the full test result is displayed in the form of a summary. In the case of error messages and malfunctions, the display colour changes to red and a corresponding text is shown. If the device is not in use, it is switched off automatically; the charging function remains active.

Technical specifications

Operating temperature range

Ambient: 0/40 °C
Storage: -20/+50 °C

Hours of operation

Max. 38 hours

Weight

Approx. 360 g (device)

Dimensions

W x H x D: 66 x 143 x 37 mm
(without connection cable)

Connection level sensor

1.2 m connection cable with coupling socket 903

Display

TFT colour display, 2.8"
W x H: 45 x 60 mm

Supply voltage

Lithium-ion battery (3.6 V/2,350 mAh)
or power supply unit (USB)

Scope of delivery

Tester with coupling socket 903,
USB power supply unit, mini USB cable,
a protective sleeve with magnet, case, instructions

Level sensor testers
with connector 903 – suitable for all level
sensor fittings.

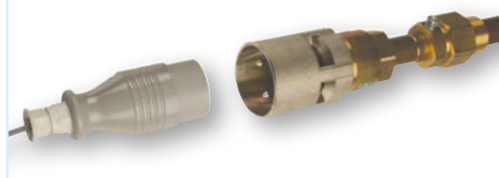

DG: H, PG: 4	Part no.	Price €
Level sensor tester GPG 01	46200	

Level sensor testers

GPR 4 / ME 6

2



GPR 4

Application For fast and easy electrical function tests of level sensors. For use with storage tanks for fuel oils and diesel fuels. Not permitted for use in hazardous areas and not for level sensors which are installed in tanks containing hazardous media.

Description Simple level sensor tester with connector, suitable for all level sensor fittings. A signal lamp indicates function or error. Battery operation. Delivery with battery and level sensor connection fitting, also suitable for level sensor with brass fitting.

Technical specifications

Level sensor testers with connector 903 – suitable for all level sensor fittings.

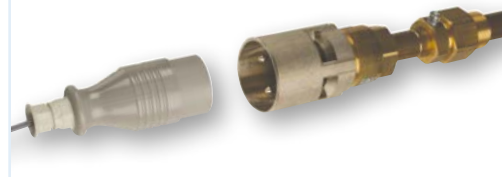

ME 6 / ME 6 P

For genuine function tests of all level sensors built to EN 13616:2004 or TRbF 511. ATEX type examination certificate.

Level sensor tester with connector. The level sensor is heated up by the intrinsically safe current of the tester. The heat-up time and the switch-off time are measured, evaluated and shown on the touch display. Version ME 6 P also detects and displays the QSS coding (quality assurance system product code) of the level sensor. The device stores the measured data; they can be transmitted to a PC via a USB cable.

Operating temperature range

Ambient: -20/+50 °C

Housing

W x H x D: 105 x 210 x 40 mm

Display

Touch display, 36 x 65 mm (W x H)

Degree of protection

IP 30

Supply voltage

4 x AA NiMH batteries (1.2 V / 2000 mAh)

Interfaces

USB-B

Scope of delivery

GWG level sensor tester with coupling socket type 903, USB charger, PC-software on USB flash drive in case

EC Type Examination Certificate

Tester: II (1) G [Ex ia Ga] II C
Coupling socket: II 2 G Ex ia II C T4 Gb

DG: H, PG: 4	Part no.	Price €
Level sensor tester GPR 4	62301	
Level sensor tester ME 6-Set	62234	
Level sensor tester ME 6 P-Set	62235	

Transducer for overfill prevention system UFS 01 (WHG)



- Compact, modern design
- With visual/audible alarms, Test and Acknowledge buttons
- 2 relay outputs for additional alarm equipment, EMS, etc.
- Fail-safe, self-monitoring transducer for maximum reliability

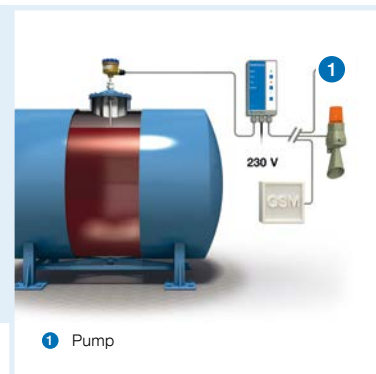
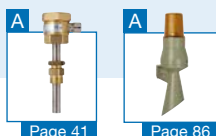

Application To avoid overfilling of stationary tanks and stationary-use tanks. Suitable for a wide range of flammable and non-flammable water-polluting liquids with a flash point > 55 °C.

Description Type-approved together with all level probes type series 76 as part of an overfill prevention system. UFS 01 in a wall mounting housing consists of a transducer and a suitable level probe (to be ordered separately). The transducer contains all display elements and controls as well as all electronic components for signal processing and conversion of the level probe signal into a digital output signal. The level probe and the transducer are connected by means of a two-wire signal cable. When the maximum permissible level is reached, UFS 01 triggers visual and audible alarms. The transducer also features two output relays for switching tasks or connection of event reporting systems, the additional alarm unit ZAG 01 or additional equipment.

Ancillary control unit type 907-Z can be connected as an additional control unit to enable connection to a road tanker with overfill alarm system.

- Media**
- Fuel oil EL, biofuel
 - Diesel/biodiesel mixtures
 - Used gearbox oils and motor oils
 - Unused motor oils, gearbox oils and hydraulic oils
 - Transformer oil
 - Hexanol 1
 - Ethyl aceto-acetate (aceto-acetic ester)
 - Acrylic acid 2-ethyl hexylene ester (2-ethyl hexylene acrylate)
 - Cyclohexyl acetate, benzaldehyde
 - Methyl aceto-acetate
 - Nitrobenzene, 1,2 dichlorobenzene
 - 2,4 dimethylaniline (N, N dimethylaniline)
 - n octanol (n octyl alcohol)
 - Diethylxalate
 - Aniline
 - Vegetable oil (also as per EN 51605)
 - Oil/water mixtures (e.g. drilling oil or lubricating oil)
 - Perchloroethylene and trichloroethylene
 - Antifreeze agents
 - Cleaning agent/water mixtures
 - AdBlue® (urea solution) as per DIN 70070

as well as comparable water-polluting liquids with identical heat conductivity with a flash point of > 55 °C.

Technical specifications

Operating temperature range

Ambient: -20/+60 °C

Supply voltage

AC 230 V or AC/DC 15–40 V

Power input: < 10 VA

Output relay

1 changeover contact / 1 normally open contact (can be acknowledged)

Housing

Wall mounting housing made of impact-resistant plastic (ABS)

W x H x D: 100 x 188 x 65 mm

Degree of protection

IP 30 (EN 60529)

Weight

0.6 kg

Approval

DiBt: Z-65.11-193



See page 41 for level probes.

	DG	PG	Part no.	Price €
Transducer UFS 01, AC 230 V	H	4	53202	
Transducer UFS 01, AC/DC 15–40 V	H	4	53216	
Mounting frame	G	1	43521	
Sealing kit (IP 54)	G	1	43416	
Ancillary control unit type 907-Z, 230 V	H	2	53232	
Ancillary control unit type 907-Z, DC 24 V	H	2	53262	

Transducer NB 220 H for overfill prevention systems (WHG)

2



- Compact design
- With visual and audible alarms
- Either as 230 V or as 24 V version

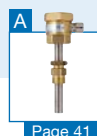

Application To avoid overfilling of stationary tanks and stationary-use tanks. Suitable for a wide range of water-polluting liquids with a flash point of > 55 °C (see product description UFS 01 for list of substances).

Description Type-approved together with all level probes type series 76 and UFS 01 as part of an overfill prevention system. When the level probe comes in contact with the liquid, the relay switches. Alarm units for visual and audible alarms are additionally required.

Technical specifications **Supply voltage**
AC 230 V or DC 24 V

Power input
Max. 4 VA / 6 W

Output
Voltage-free changeover contact

Contact rating
AC 250 V, max. 500 VA

Housing (degree of protection)
Plug-in housing (IP 30)
W x H x D: 50 x 110 x 110 mm

Approval
DIBt: Z-65.11-193

i

See page 41 for level probes.
See page 39 for a list of liquids (substances).
See page 88 for additional alarm unit ZAG 01 with visual/audible alarms.

DG: H	PG			Part no.	Price €
Transducer NB 220 H – AC 230 V	4	1	-	53210	
Transducer NB 220 H – DC 24 V	4	1	-	53219	

Level probes for overfill prevention systems (WHG)



2

Application Level probe for transducers as part of an overfill prevention system for stationary tanks and stationary-use tanks used to store water-polluting liquids with a flash point of > 55 °C (see product description UFS 01 for list of substances).

Level probe type 76 A

Description Approved as part of an overfill prevention system together with level transducers UFS 01 and NB 220 H. The level probe type 76 A consists of a probe tube with a stainless steel-encapsulated PTC thermistor sensor at the lower end, a junction box and a screw fitting. Tube length 100 to 3,000 mm in increments of 100 mm. Standard lengths up to 500 mm. The overfill prevention system must be set up in such a way that a sufficiently loud audible alarm is triggered when the maximum permissible level is reached.

Technical specifications

Material

Junction box: Brass
 Probe tube: Stainless steel 316 Ti or 304
 Screw fitting: Brass
 PTC thermistor: Stainless steel-encapsulated

Process connection

Connection thread G $\frac{3}{4}$

Operating temperature range

Medium: -25/+50 °C

Degree of protection

IP 54 (EN 60529)

Approval

DIBt: Z-65.11-185

Level probe type 76 AH

Approved as part of an overfill prevention system together with level transducers UFS 01 and NB 220 H. The level probe type 76 AH consists of a probe tube with a stainless steel-encapsulated PTC thermistor sensor at the lower end, a junction box and a screw fitting. Tube length 100 to 3,000 mm in increments of 100 mm. Standard lengths up to 500 mm. The overfill prevention system must be set up in such a way that a visual alarm and a sufficiently loud audible alarm are triggered when the maximum permissible level is reached.

Material

Junction box: Brass
 Probe tube: Stainless steel 304 or 316 Ti
 Screw fitting: Brass
 PTC thermistor: Stainless steel-encapsulated

Process connection

Connection thread G $\frac{3}{4}$

Operating temperature range

Medium: -25/+80 °C

Degree of protection

IP 54 (EN 60529)

Approval

DIBt: Z-65.11-185

DG: H, PG: 3	Part no.	Price €
Level probe type 76 A		
100 mm	53225	
200 mm	53217	
300 mm	53220	
400 mm	53207	
500 mm	53209	
Extra charge per 100 mm	–	
Level probe type 76 AH*		
500 mm	53214	

* Please enquire for other response lengths.



See page 39 for a list of liquids (list of substances).

Overfill prevention system LS ATEX (WHG)



2



Transducer LS 500

Application To avoid overfilling of stationary tanks and stationary-use tanks. Approved without list of substances for water-polluting liquids, also with flash point < 55 °C.

Description Transducer with test button. Type-approved together with the level probes LS 300 EU, LS 300 FU or LS 300 ESPU as part of an overfill prevention system. The transducer supplies the level probe via an intrinsically safe circuit, evaluates the change in resistance of the PTC thermistor, continuously checks the PTC thermistor operation and monitors the system (power outage, short circuit, line interruption, etc.). Negative results cause the overfill prevention system to respond. The additional alarm unit ZAG 01 can also be connected.

The overfill prevention system must be set up in such a way that visual and audible alarms are triggered when the maximum permissible level is reached. The transducer must be installed outside of the hazardous area.

Technical specifications

Supply circuit

Supply voltage: AC 230 V
Power input: Max. 4 VA
(Supply voltage: DC 24 V or AC 24 V at extra charge)
Output current circuit 1 voltage-free changeover contact
Sensor current circuit (intrinsically safe)
Voltage: < DC 15.8 V
Current: < 154 mA
Power: < 600 mW

Operating temperature range
-25/+50 °C

Housing (degree of protection)

Wall mounting housing (IP 40)
W x H x D: 75 x 150 x 110 mm

Approval

DIBt: Z-65.11-228

EC Type Examination Certificate:
TÜV 00 ATEX 1641 Ex II (1)G [Ex ia] IIC



All wetted parts
made of stainless
steel 316 Ti

Level probe LS 300 EU

Level probe for transducers as part of an overfill prevention system for stationary and stationary-use tanks. Suitable for installation in all tank versions. Approved without list of substances for water-polluting liquids, also with flash point < 55 °C.

Approved part of an overfill prevention system according to WHG together with the LS 500 transducer – self-monitoring and with automatic corrosion monitoring. LS 300 EU consists of a height-adjustable probe tube made of stainless steel with a PTC thermistor sensor element at the lower end, a screw fitting and a brass junction box with integrated overvoltage protection. Standard length 500 mm, max. length 3,000 mm. The level probe can be used in liquids up to 3 bar overpressure.

Material

Junction box: Brass, chrome-plated
Probe tube: Stainless steel 316 Ti
Screw fitting: Stainless steel 316 Ti
PTC thermistor: Stainless steel-encapsulated

Process connection

Screw fitting G³/₈

Operating temperature range

Medium: -25/+50 °C

Degree of protection

IP 67 (EN 60529)

Approval

DIBt: Z-65.11-228

EC Type Examination Certificate:
TÜV 00 ATEX 1656X
Ex II 1G Ex ia IIC T4
Ex II 1/2G Ex ia IIC T4

DG: H, PG: 4	Part no.	Price €
LS 500	53310	
Level probe LS 300 EU, 500 mm	53300	
Extra charge per 100 mm (from 500 mm)	-	

PTC thermistor level controller RG 210



- Compact control unit
- Universal application due to selectable functions

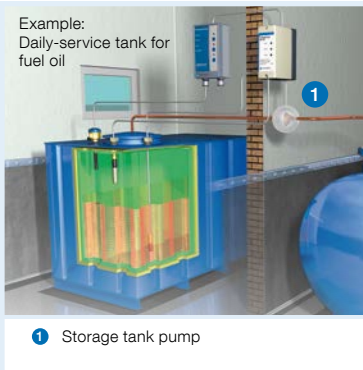

1 Storage tank pump

Application For use in electrically non-conductive liquids which are not viscous or adhesive, such as fuel oil, diesel fuel and media which are not corrosive.

Description PTC thermistor type level controller with selectable functions:

- Level switch (1 probe)
- Level control for filling (2 probes)
- Level control for emptying (2 probes)

Level switch with 1 probe:

The relay switches in case of contact or loss of contact with the liquid. When the switch point is set, it must be observed that the PTC thermistor requires approx. 8 seconds to heat up depending on the ambient temperature.

Level control for filling with 2 probes:

Set internal switch to "fill". The relay energises after the min. probe has heated up. Relay de-energises when the max. probe comes into contact with the liquid.

Level control for emptying with 2 probes:

Set internal switch to "empty". Relay energises when max. probe has contact with the liquid. Relay de-energises when the min. probe loses contact with the liquid and heats up.

Technical specifications

Operating temperature range

Medium: -25/+55 °C
Ambient: -10/+55 °C

Probe

PTC thermistor probe, type 937
Cable length 3 m (max. 50 m)
Process connection G½, G1

Supply voltage

AC 230 V

Power input

12 VA

Relay contact (output)

1 changeover contact voltage-free

Housing (degree of protection)



Plug-in housing (IP 30)
W x H x D: 53 x 113 x 108 mm

Flexible PTC thermistor probe type 937

Flexible PTC thermistor designed for oils and other electrically non-conductive liquids (low-viscosity, non-adhesive). The PTC thermistor connection wires are not encapsulated. Not suitable for installation in humid environments.

i

Note: Not to be used as an overflow prevention system according to WHG. Requires the connection of an overflow prevention system according to WHG.

DG: H, PG: 4			Part no.	Price €
Level controller RG 210	1	-	53206	
Flexible PTC thermistor probe type 937	1	-	53204	



Liquid-based leak detector LAG



Vacuum type leak detector EUROVAC



Leak detectors - sight glass principle



Inner tank linings

Leak detectors, leak monitoring systems and leak protection linings

OVERVIEW

Leak protection, leak monitoring and oil tank conversion	46
Vacuum type leak detector Eurovac	52

LEAK DETECTION

Leak detectors – sight glass principle LAS	48
Leak detector LAG-13 KR	49
Leak detector LAG-14 ER	50
Accessories for leak detectors	51
Vacuum type leak detector Eurovac NV	53
Vacuum type leak detector Eurovac HV	54
Protective equipment for leak detectors: Liquid barrier , condensate bar	55
Spare parts for leak detectors	56
Pressure type leak detector Europress	62

LEAK PROTECTION

Tank protection package AK-S for fuel oil, diesel	57
Inner linings AF-S for liquid fertiliser AHL, AdBlue®	58
Inner linings AR-S for rainwater harvesting	59
Rainwater inner lining AR-SM with magnets	60
Mounting accessories for inner linings	61

Professional equipment and convincing solutions for tank protection

With a comprehensive range of building technology products, AFRISO prides itself in "Making Heating Systems Safe". In addition to this extensive range, a large selection of alarm instruments for the fast detection of level, liquid spillage, leakage, gas or smoke is available.

3

Advantages – your benefits

- Complete range of products for professional tank protection from a single supplier
- Maximum protection against fuel oil accidents with brand products with approval for construction products
- Chemical resistance even if used with biodiesel, biofuel or admixtures
- Inner linings exactly made to size and ready for easy installation
- 10 years warranty on material and workmanship for plastic inner linings
- Fittings and devices ready to be installed, with all required mounting accessories

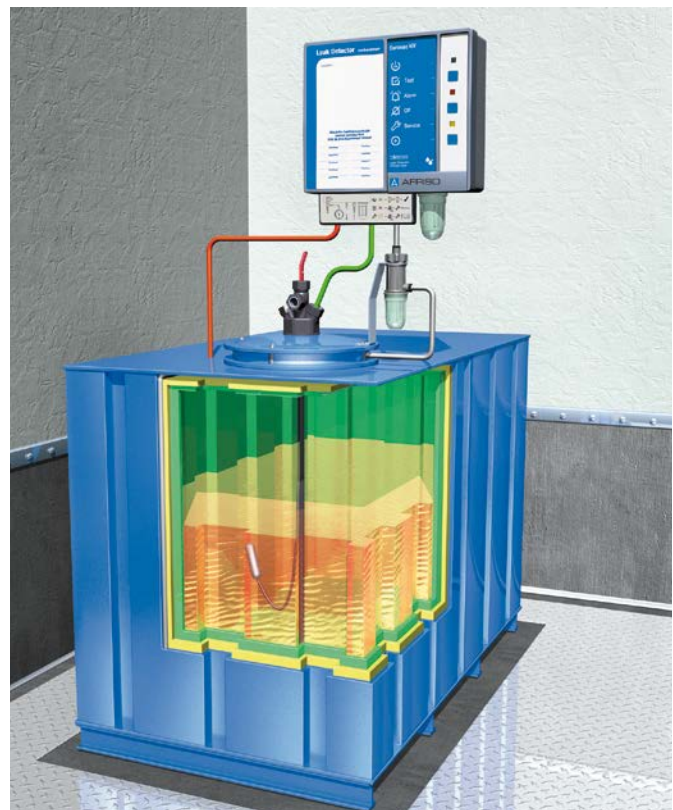

Leak protection lining

The installation of customised AFRISO leak protection linings turns single-walled steel tanks into double-walled tanks. Complex drip pans or collection facilities are no longer required. Oil cannot escape even if there is a leak in the outer tank wall. The Eurovac leak detector uses a vacuum in the interstitial space between the inner lining and the tank wall to monitor both walls for leaks. Malfunctions and leaks are immediately signalled.

Leak detectors and alarm units WATCHDOG-LINE

The uniform appearance not only ensures customer confidence, but also underpins the professionalism of the specialised company.



3

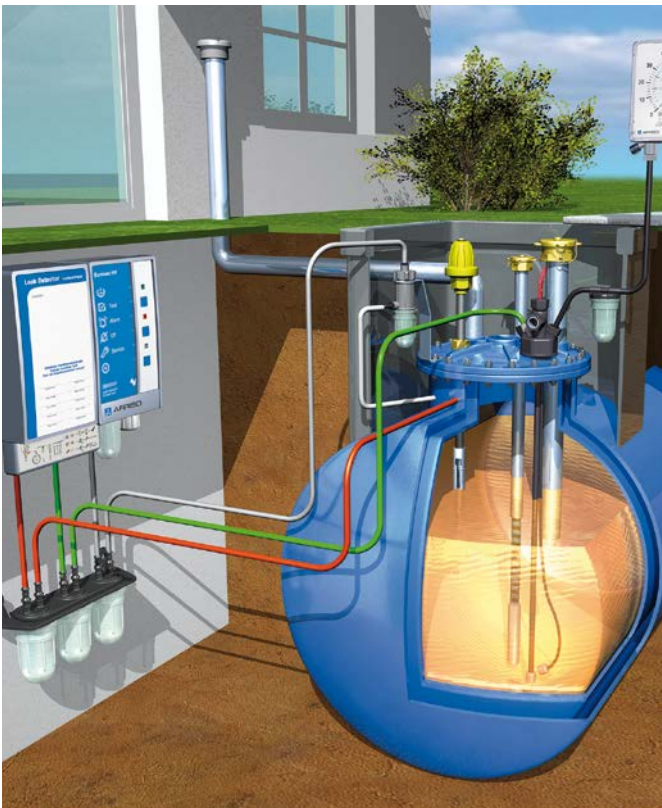

Leak monitoring

Application areas

- Cylindrical steel or plastic (glass-fibre reinforced plastic) tanks
- Double-walled steel tanks
- Steel tanks manufactured on site
- Spherical tanks
- Tanks with inner lining
- Inspection ducts
- Oil storage rooms/collection facilities
- Containers, cisterns, cesspits

Media

- Fuel oil EL
- Diesel fuel
- Biofuel
- Biodiesel
- AHL
- AdBlue®
- Rainwater
- Other liquids

Oil tank conversion kits

If oil tanks can no longer be used or if the heating system is converted to other types of energy or if old unused cesspits and cisterns are available, the containers can be equipped with a plastic inner lining for rainwater harvesting and integrated into a rainwater harvesting system.

Various conversion kits, inner linings and a complete range of accessories are available.

Leak detectors LAS – sight glass principle

3

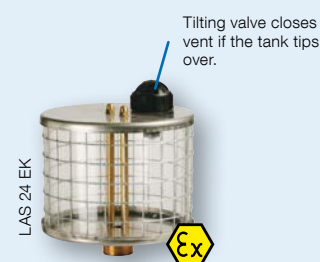

Application For aboveground double-walled tanks containing water-polluting liquids. Application under atmospheric conditions for steel tanks and double-walled tanks with approval for leak detectors. Types LAS 24 E, LAS 39 E and LAS 72 E for all water-polluting liquids. Types LAS 24, LAS 39, LAS 72 and LAS 230 for water-polluting liquids with a flash point of > 55 °C.

Description Leak detector for liquid systems consisting of a transparent acrylic glass cylinder, stainless steel housing covers and bottoms. Connection thread G1. Certification DIBt: Z-65.24-381.

Versions Version E with wire mesh cylinder. LAS 24 EK for mobile tanks with tilting valve to protect against loss of leak detection fluid during transport and for venting on site. LAS 39 and 72 with G1 connection at the side for up to 4 additional containers with 4.5 litres each. The additional containers allow for leak detection at tanks with a greater interstitial space (see overview).

Overview LAS 72 with additional containers

Number of additional containers	Active volume LAS 72 and additional containers in litres	Max. leak detection fluid in the interstitial space in litres	To be used for tanks with a volume in litres up to
0	2.1 l	Max. 72 l	approx. 7,000 l
1	6.6 l	Max. 230 l	approx. 30,000 l
2	11.1 l	Max. 387 l	approx. 50,000 l
3	15.6 l	Max. 545 l	approx. 80,000 l
4	20.1 l	max. 700 l*	100,000 l

Values for LAS 39, 230 on request.

* Design 1975–1985.

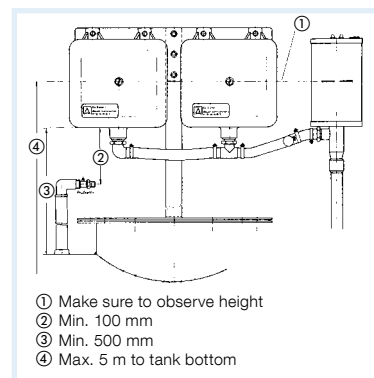

DG: H, PG: 3	Active volume	Interstitial space of tank	Max. no. of additional tanks	Part no.	Price €
LAS 24	0.7 l	Max. 24 l	-	43515	
LAS 24 E	0.7 l	Max. 24 l	-	43516	
LAS 24 EK	0.7 l	Max. 24 l	-	43517	
LAS 39	1.1 l	Max. 39 l	-	43526	
LAS 39 E	1.1 l	Max. 39 l	-	43525	
LAS 72	2.1 l	Max. 72 l	4	43528	
LAS 72 E	2.1 l	Max. 72 l	4	43527	
LAS 230	6.6 l	Max. 232 l	4	43550	
Mounting kit LAS 0 (test valve)	-	-	-	43529	
Mounting kit LAS 1*	-	-	-	43530	
Mounting kit LAS 2*	-	-	-	43531	
Mounting kit LAS 3*	-	-	-	43532	
Mounting kit LAS 4*	-	-	-	43533	

* Including the corresponding number of additional containers (Ex-Elstat l).

Leak detector LAG-13 KR

Class II, EN 13160-1/-3



- Version as per WHG and BetrSichV
- For monitoring of aboveground, double-walled tanks
- With fail-safe mode



3

Application For double-walled tanks with liquid in the interstitial space. For monitoring water-polluting liquids with a flash point of > 55 °C stored aboveground. Approved for all suitable tanks under atmospheric conditions.

Since July 2003, the LAG-13 KR leak detector may only be used for replacements of existing systems at underground, double-walled tanks as a result of the reclassification of water-polluting liquids in Germany!

Description Leak detector class II (EN 13160-1/-3). The system consists of a control unit, a container for leak detection fluid (LAG container white) and a probe. Control unit with operating and alarm indicators, audible/visual alarm, test button and increased interference protection. The audible alarm can be muted with the Acknowledge button. The voltage-free relay contact is provided for connection of additional external alarm equipment (such as horns,) or an additional alarm unit ZAG 01. With fail-safe mode: Audible alarm if the probe fails. Suitable for panel mounting with a mounting frame; a sealing kit (IP 54) is available for rough application conditions. The LAG container serves as detection container and as expansion vessel at the same time. For aboveground tanks, the ratio between usable contents and total volume of leak detection fluid must be no more than 1:35. If the interstitial space has a greater volume, you must use additional containers.

Technical specifications

Operating temperature range

Ambient: -5/+50 °C
Storage: -10/+60 °C

Supply voltage

AC 230 V

Control unit

Wall mounting housing made of impact-resistant plastic (ABS)
W x H x D: 100 x 188 x 65 mm
Degree of protection: IP 30 (EN 60529)

Switching outputs

Relay output: 1 voltage-free changeover contact
Contact rating: AC 250 V, 2A

Tanks

Plastic, white
W x H x D: 300 x 325 x 145 mm
Usable contents / total contents: 4.5 l / 10 l
Outlet: G $\frac{3}{4}$ female
Degree of protection: IP 20 (EN 60529)

Certification

CE-marking as per EC Construction Products Regulation 305/2011, EU 574/2014, EN 13160-1/-3 and ÜHP

DG: G	PG			Part no.	Price €
LAG-13 KR , including container and probe	4	1	5	43500	
LAG container white , without probe	1	1	-	40730	
Control unit LAG-13 KR	4	1	-	40630	
Accessories					
Mounting frame	1	1	-	43521	
Sealing kit (IP 54)	1	1	-	43416	
LAG mounting kit	1	1	-	40540	
Mounting kit for 1 additional LAG container (without container)	1	1	-	40539	
Leak detection fluid – concentrate	1	1	-	43645	

i

See page 51 for a detailed product description LAG container.

Leak detector LAG-14 ER



Class II, EN 13160-1/-3



- **ATEX type examination certificate**
- **Version as per German WHG and BetrSichV**
- **With fail-safe mode**
- **For monitoring of aboveground, double-walled tanks**

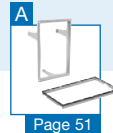

Application For double-walled tanks with liquid in the interstitial space. For monitoring water-polluting liquids stored aboveground. The LAG container can be installed in hazardous areas zones 0, I and II (e.g. manhole of petrol tanks). Approved for all suitable tanks under atmospheric conditions.

Since July 2003, the LAG-14 leak detector may only be used for replacements of existing systems at underground, double-walled tanks as a result of the reclassification of water-polluting liquids in Germany!

Description Class II leak detector (EN 13160-1/-3) with intrinsically safe probe circuit. The system consists of a control unit, a container for leak detection fluid (LAG container black) and a probe. Control unit with operating and alarm indicators, audible/visual alarm, test button and increased interference protection. The audible alarm can be muted with the Acknowledge button. The voltage-free relay contact is provided for connection of additional external alarm equipment (such as horns,) or an additional alarm unit ZAG 01. With fail-safe mode: Audible alarm if the probe fails. Suitable for panel mounting with a mounting frame; a sealing kit (IP 54) is available for rough application conditions. The LAG container serves as detection container and as expansion vessel at the same time. For aboveground tanks, the ratio between usable contents and total volume of leak detection fluid must be no more than 1:35. If the interstitial space has a greater volume, you must use additional containers.

Technical specifications

Operating temperature range

Ambient: -20/+50 °C
Storage: -20/+60 °C

Supply voltage

AC 230 V

Control unit

W x H x D: 100 x 188 x 65 mm
Degree of protection: IP 30 (EN 60529)

Switching outputs

Relay outputs: 1 voltage-free changeover contact
Contact rating: AC 250 V, 2A

Tanks

Antistatic plastic, black
W x H x D: 300 x 325 x 145 mm
Usable contents / total contents: 4.5 l / 10 l
Outlet: G $\frac{3}{4}$ female
Degree of protection: IP 20 (EN 60529)

Certification

CE-marking as per EC Construction Products Regulation 305/2011, EU 574/2014, EN 13160-1/-3 and ÜHP

ATEX type examination certificate

EX5 11 02 15639 011
Ex II (1) G [Ex ia] IIC

DG: G	PG			Part no.	Price €
LAG-14 ER with relay, including container and probe	4	1	5	43410	
LAG container black without probe	1	1	5	40731	
Control unit LAG-14 ER	4	1	-	40642	
Accessories					
Mounting frame	1	1	-	43521	
Sealing kit (IP 54)	1	1	-	43416	



See page 51 for a detailed product description LAG container.

Accessories for leak detectors

LAG container

Description Detection container for LAG leak detectors. The LAG container also serves as an expansion vessel. For aboveground tanks, the ratio between usable contents and total volume of leak detection fluid must be no more than 1:35. If the interstitial space has a greater volume, you must use additional containers.

Since July 2003, the LAG-14 ER leak detector may only be used for replacements of existing systems at underground, double-walled tanks as a result of the reclassification of water-polluting liquids in Germany.

Technical specifications

LAG container black

Suitable for LAG-14 ER, for all stored liquids
W x H x D: 300 x 325 x 145 mm
Usable contents / total contents: 4.5 l / 10 l
Outlet: G $\frac{3}{4}$
Degree of protection: IP 20 (EN 60529)

Technical specifications

LAG container white

Suitable for LAG-13 K,
for all liquids with a flash point
> 55 °C
W x H x D: 300 x 325 x 145 mm
Usable contents / total contents: 4.5 l / 10 l
Outlet: G $\frac{3}{4}$
Degree of protection: IP 20 (EN 60529)

LAG mounting kit

Description For approved hydraulic mounting of leak detectors.

Leak detection fluid concentrate

Description For use with leak detectors for double-walled tanks. Concentrate for mixing the leak detection fluid for the interstitial space. 10 l container with 4 l leak detection fluid Antifrogen N (BAM no: 1.3/9790-5.1/3436), can be mixed with water to 8 l at up to -30 °C or 10 l up to -25 °C. Please enquire for larger containers.

Mounting frame and sealing kit

Description Suitable for all wall mounting housings of the WATCHDOG-LINE alarm units series. Mounting frame for fast integration into control cabinet. Sealing kit for rough application conditions. The sealing kit is easy to mount between the housing cover and base. With this measure, the alarm unit reaches degree of protection IP 54 (not suitable for DTA 10/20 and RENA).



LAG container black



LAG container white

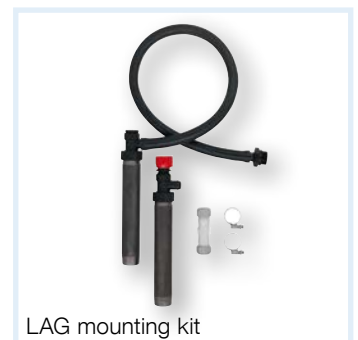

LAG mounting kit



Leak detection fluid – concentrate



Mounting frame and sealing kit

3

DG: G, PG: 1			Part no.	Price €
LAG container white	1	1	40730	
LAG container black	1	1	40731	
LAG mounting kit	1	-	40540	
Mounting kit für 1 LAG additional container (container not in scope of delivery)	1	1	40539	
Leak detection fluid – concentrate	1	-	43645	
Mounting frame	1	1	43521	
Sealing kit (IP 54)	1	1	43416	

Vacuum type leak detector Eurovac

Your benefits

- Leak detector class I, EN 13160-1/-2
- Modern housing design, in line with WATCHDOG-LINE alarm unit series
- Large supply voltage range (AC 100-240 V) for worldwide application
- With power outage monitoring (with optional 9 V battery)
- Indication of pump operating time
- Low-noise operation
- Electronic pressure sensor for permanently stable switching points
- Drilling template included - for easy and fast installation
- Relay output for additional signalling devices, additional alarm units, event reporting systems or for integration into building control systems
- Version in protective housing (IP 55), available with heating and/or horn



3

Robust wall mounting housing with hole pattern – suitable for most standard vacuum type leak detectors



High energy efficiency: Economical, powerful DC motor with high starting torque

Hose connection (Ø 4/6 mm) for the pneumatic connection to the interstitial space of the tanks

Connection measuring line

Connection exhaust line

Connection suction line



EnOcean-ready

Can be combined with EnOcean® wireless module TCM 320 for integration into building automation systems.



Control panel with visual/audible alarms and Acknowledge button

Service indicator for annual maintenance

Supply voltage

Sintered plastic filter and condensate trap to indicate the current degree of pollution and to protect the pump

Vacuum type leak detector Eurovac NV

as per WHG and BetrSichV, EN 13160-1/-2, class I



- With visual and audible alarms, Acknowledge button and switching output
- High energy efficiency: Economical, powerful DC motor with high starting torque
- Service indicator for annual maintenance
- With power outage monitoring

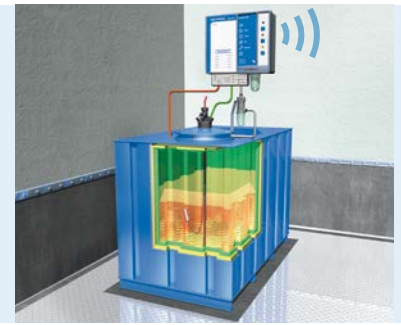

3

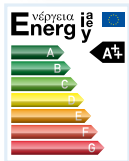

Application Class I vacuum type leak detector according to EN 13160-1/-2 for safe monitoring of double-walled tanks and single-walled tanks with inner lining for the unpressurised storage of water-polluting liquids with a flash point > 55 °C, also AdBlue® (urea solution 32.5 %) according to DIN 70070 or other media (e.g. used hydraulic oil, cooling agent from grinding processes, etc). The broad voltage range (AC 100–240 V) allows for applications in a large variety of countries.

Description Compact leak detector in a robust wall mounting housing with audible and visual alarms. The audible alarm can be muted with the Acknowledge button. Eurovac NV maintains a vacuum in the interstitial space of the tank in the low range. The vacuum pump is operated by an economical DC motor with a high starting torque (energy efficiency class AA++). Eurovac features a switching output for additional equipment (such as additional alarm unit ZAG 01) or integration into building control systems. The pump operating time can be displayed. Three hose connections (red, white, green) for the pneumatic connection to the interstitial space of the tank. The universal connection pieces can be used for 4 mm and 6 mm hoses.

With condensate trap to protect the electronics. Electrical connection from the top or from the bottom. An optional 9 V battery can be connected so that an alarm is triggered in the case of power outage. For outdoor applications, Eurovac NV is available in a protective housing (IP 55).

Alarm units with the EnOcean-ready label allow for wireless integration into a building automation system. To do so, plug the EnOcean® wireless module TCM 320 into the EnOcean® interface (PCB of the device). The AFRISOhome gateway in conjunction with additional AFRISO smart home products with EnOcean® wireless technology allow you to configure a whole range of fully customisable, extensible features for the protection of plants and buildings.

Technical specifications

Operating temperature range

Ambient: -5/+50 °C

In protective housing with heating: -25/+50 °C

Supply voltage

AC 100–240 V

Nominal power

< 10 VA

Switching output

Relay contact: 1 voltage-free changeover contact

Contact rating

Max. 250 V, 2 A, resistive load

Operating pressure

Interstitial space: Approx. -70 mbar

Housing

Wall mounting housing made of impact-resistant plastic (ABS)

W x H x D: 202 x 230 x 70 mm

Degree of protection: IP 30 (EN 60529)

Alarm sound

Min. 70 dB(A)

Certification

CE-marking as per EC Construction Products Regulation 305/2011, EU 574/2014, EN 13160-1/-2 and ÜHP

i

See page 57 for inner linings and mounting accessories.

See the catalogue PORTABLE MEASURING INSTRUMENTS for testers for vacuum type leak detectors.

PG: 4	DG	Part no.	Price €
Eurovac NV (low vacuum)	H	43755	
Eurovac NV in protective housing (IP 55)	H	43788	
Eurovac NV in protective housing (IP 55) with horn	H	43782	
Eurovac NV in protective housing (IP 55) with heating	H	43792	
Eurovac NV in protective housing (IP 55) with heating and horn	H	43789	
EnOcean® wireless module TCM 320	G	78082	

Vacuum type leak detector Eurovac HV

as per WHG and BetrSichV, EN 13160-1/-2, class I



- With visual and audible alarms, Acknowledge button and switching output
- High energy efficiency: Economical, powerful DC motor with high starting torque
- Service indicator for annual maintenance
- With power outage monitoring

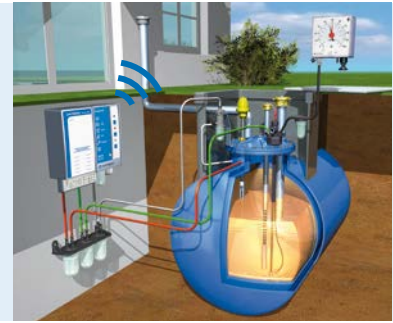

Application

Class vacuum type leak detector according to EN 13160-1/-2 for safe monitoring of double-walled tanks and single-walled tanks with inner lining for the unpressurised storage of water-polluting liquids with a flash point > 55 °C, also AdBlue® (urea solution 32.5 %) according to DIN 70070 or other media (e.g. used oil, hydraulic oil, cooling agent from grinding processes, brake fluid, etc.). The broad voltage range (AC 100–240 V) allows for applications in a large variety of countries.

Description

Compact leak detector in a robust wall mounting housing with audible and visual alarms. The audible alarm can be muted with the Acknowledge button. Eurovac HV maintains a vacuum in the interstitial space of the tank in the high range. The vacuum pump is operated by an economical DC motor with a high starting torque (energy efficiency class A++). Eurovac features a switching output for additional equipment (such as additional alarm unit ZAG 01) or integration into building control systems. The pump operating time can be displayed.

Three hose connections (red, white, green) for the pneumatic connection to the interstitial space of the tank. The universal connection pieces can be used for 4 mm and 6 mm hoses. With condensate trap to protect the electronics. Electrical connection from the top or from the bottom. An optional 9 V battery can be connected so that an alarm is triggered in the case of power outage. For outdoor applications, Eurovac HV is available in a protective housing (IP 55).

Alarm units with the EnOcean-ready label allow for wireless integration into a building automation system. To do so, plug the EnOcean® wireless module TCM 320 into the EnOcean® interface (PCB of the device). The AFRISOhome gateway in conjunction with additional AFRISO smart home products with EnOcean® wireless technology allow you to configure a whole range of fully customisable, extensible features for the protection of plants and buildings.

Technical specifications

Operating temperature range

Ambient: -5/+50 °C
In protective housing with heating: -25/+50 °C

Supply voltage

AC 100–240 V

Nominal power

< 10 VA

Switching output

Relay contact: 1 voltage-free changeover contact

Contact rating

Max. 250 V, 2 A, resistive load

Operating pressure

Interstitial space: Approx. -400 mbar

Housing

Wall mounting housing made of impact-resistant plastic (ABS)
W x H x D: 202 x 230 x 70 mm
Degree of protection: IP 30 (EN 60259)

Alarm sound

Min. 70 dB(A)

Certification

CE-marking as per EC Construction Products Regulation 305/2011, EU 574/2014, EN 13160-1/-2 and ÜHP

i

See page 57 for inner linings and a complete range of mounting accessories. See the catalogue PORTABLE MEASURING INSTRUMENTS for testers for vacuum type leak detectors.

PG: 4	DG	Part no.	Price €
Eurovac HV (high vacuum)	H	43750	
Eurovac HV in protective housing (IP 55)	H	43774	
Eurovac HV in protective housing (IP 55) with horn	H	43776	
Eurovac HV in protective housing (IP 55) with heating	H	43793	
Eurovac HV in protective housing (IP 55) with heating and horn	H	43781	
EnOcean® wireless module TCM 320	G	78082	

Protective equipment for Eurovac leak detectors



Liquid barrier

Application For increased reliability and for the protection of vacuum type leak detectors.

Description Liquid barrier with condensate trap for visual inspection, complete with fixing bracket for easy mounting to manhole cover. The liquid barrier is mounted directly into the suction line between the leak detector and the double-walled tank. The liquid carried in the suction line (condensate or, in the event of a leak, the medium or groundwater) is collected in the condensate trap of the liquid barrier. An integrated float shuts off the suction line if too much liquid is contained in the liquid barrier. The condensate trap can be easily unscrewed for emptying.

- Tightness-tested
- Compact, robust design made of high-strength plastic
- Compatible with hoses with 4/6 mm inside diameter

Technical specifications **Hose connection** Interchangeable Ø 4 or 6 mm

Housing Plastic

Scope of delivery

- Liquid barrier with condensate trap
- Mounting bracket
- Hose connection Ø 4/6 mm



3

Condensate bar

For the protection of vacuum type leak detectors used on double-walled tanks to avoid ingress of condensate liquid into the device or clogging of hoses.

Condensate bar with three condensate traps for visual inspection, with integrated bracket for easy wall mounting. If there is no steady gradient in the measuring, exhaust and suction lines from the leak detector to the tank, a condensate bar must be mounted at each lowest point of the lines. When condensate forms, the liquid is collected in the relevant condensate trap. The condensate traps can be easily unscrewed for emptying.

- Tightness-tested
- Compact, robust design made of high-strength plastic
- Compatible with hoses with 4/6 mm inside diameter

Hose connection Ø 4 and 6 mm

Housing Plastic

Scope of delivery

Condensate bar with 3 condensate traps

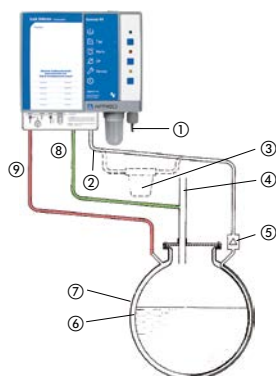

Mounting diagram



- ① Electrical connection
- ② Suction line (transparent)
- ③ Condensate trap/condensate bar
- ④ Tank vent
- ⑤ Liquid barrier
- ⑥ Interstitial space
- ⑦ Outer wall of tank
- ⑧ Exhaust line (green)
- ⑨ Measuring line (red)

DG: H, PG: 1			Part no.	Price €
Liquid barrier	1	1	43646	
Condensate bar	1	20	43692	



Spare parts for leak detectors

When ordering spare parts, please specify the unit designation (refer to type designation plate on the control unit). Spare parts for discontinued models are also listed. Visit www.afriso.com for additional spare parts lists.

LAG spare parts

DG: G	PG			Part no.	Price €
LAG probe, plug-in connection, for LAG 13 and LAG 14	1	1	-	40510	
Foil keypad for control units year of manufacture 1996 and later	4	1	-	18 05 000002	
Foil keypad for control units year of manufacture 2007 and later	4	1	-	18 05 000003	
Spare parts LAG mounting kit					
Test valve plastic, complete	1	1	-	40555	
Hose connection G1 (angled)	1	1	-	40557	
Hose nipple G$\frac{3}{4}$	1	1	-	40558	
Hose EPDM 14 x 3 (reel with 10 m)	1	1	-	40544	

Eurovac/Europress spare parts

DG: H	PG			Part no.	Price €
Pump with motor Eurovac HV	4	1	-	43777	
Pump with motor Eurovac NV	4	1	-	43783	
Foil keypad Eurovac / Europress	4	1	-	18 05 000004	

i

Contact our service department if you have questions concerning spare parts.

E-mail: service@afriso.de
Phone: +49 7135 102-211

Tank protection package AK-S for fuel oil and diesel – Inner linings with complete accessories



as per EN 13160-7

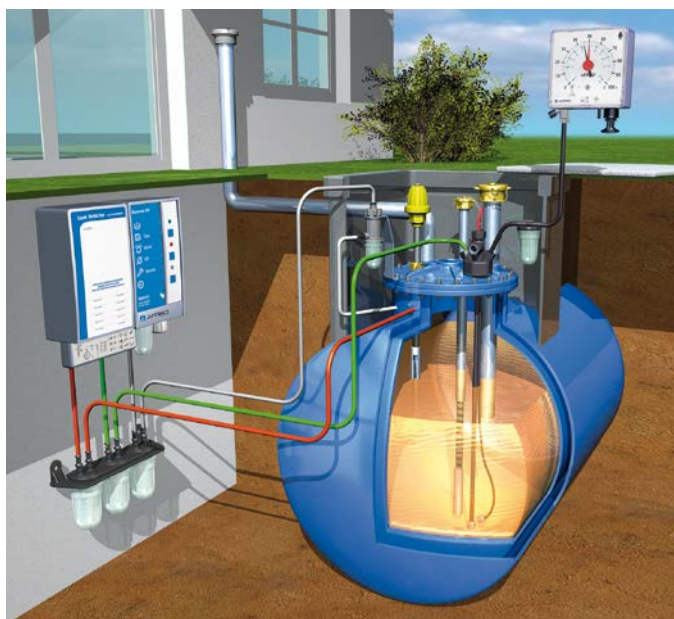

Application

For fuel oil EL (DIN 51603-1), diesel fuel (EN 590) and biofuel as well as biodiesel with up to 20 % FAME.

Description

Tank protection package for standardised cylindrical tanks. Enquire for rectangular and spherical tanks.

Certification

CE as per European Construction Products Regulation ((EU) No 305/2011 and No 574/2014), EN 13160-1:2003, EN 13160-7:2003
DIBt: Z-65.30-162

3

Scope of delivery

- Leak protection lining according to standard or made to size
- Vacuum type leak detector Eurovac
- Front wall lining made of fleece LSV2
- Intermediate layer made of fleece
- Mipoplast plate 800 x 800 mm
- Condensate bar triple 4/6 mm
- Liquid barrier 4/6 mm
- Angled nipple short 4/6 mm
- Angled nipple long 4/6 mm
- PVC suction line 3 x 6 mm perforated and not perforated
- Fastening ring 500 mm or 600 mm
- Hose connector 4 or 6 mm
- T piece hose connection 4 or 6 mm
- Hose connector kit G $\frac{3}{8}$ x G $\frac{1}{2}$ x G $\frac{3}{8}$
- Warning sign with holder and felt overshoes

AK-S for cylindrical, standard tanks (EN/DIN)

DG: H, PG: 1	Part no.	Price €
3,000 I	43901.003	
5,000 I	43901.005	
7,000 I	43901.007	
10,000 I	43901.010	
13,000 I	43901.013	
15,000 I	43901.015	
16,000 I	43901.016	
20,000 I	43901.020	
25,000 I	43901.025	
30,000 I	43901.030	
40,000 I	43901.040	On request
50,000 I	43901.050	On request
60,000 I	43901.060	On request
80,000 I	43901.080	On request
100,000 I	43901.100	On request

i

On request:

- Dimensional drawings for customised inner linings
- Tank protection packages for rectangular and spherical tanks
- Training seminars on installation of inner linings and leak detectors

Inner linings AF-S for the storage of liquid fertiliser AHL, AdBlue®

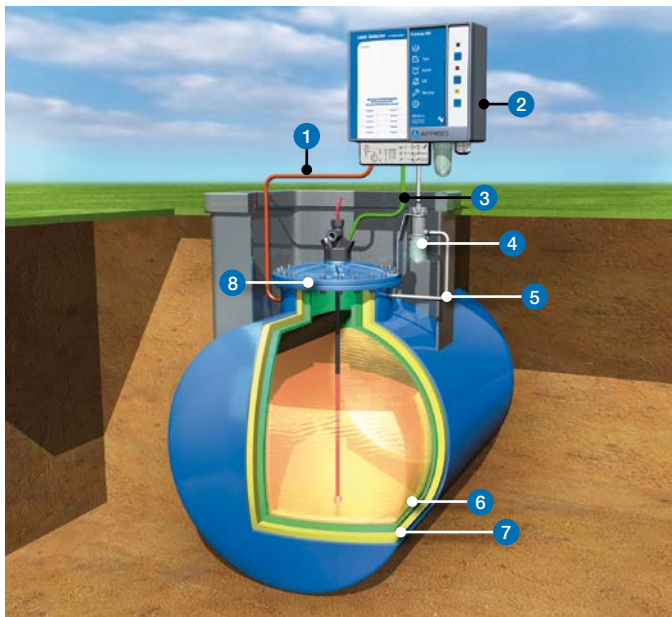

- | | |
|-------------------------|----------------------------------------|
| 1 Measuring line | 5 Suction line/suction line perforated |
| 2 Leak detector Eurovac | 6 Inner lining |
| 3 Exhaust line | 7 Intermediate layer (fleece) |
| 4 Liquid barrier | 8 Fastening ring |

Application

For liquid fertiliser AHL and urea solution 32.5 % AdBlue®. Enquire for other liquids.

Description

Plastic inner linings, blue, with Technical Approval of the German Institute for Civil Engineering (DIBt) for cylindrical standard tanks and rectangular or spherical tanks. Made of PVC film WP6120, 0.8 mm thick.

When AdBlue® is stored, the surface temperature must not exceed 35 °C!

Certification

DIBt: Z-65.30-483

Inner linings for AHL and AdBlue® for cylindrical standard tanks (EN/DIN)

DG: H, PG: 1	Part no.	Price €
Inner linings AF-S for AHL and AdBlue® for rectangular tanks per m²	43870	
Stainless steel fastening ring V2A flat steel (without seal), 40 x 8 mm, glass bead blasted, 500 mm diameter.	43900N	
Stainless steel fastening ring V2A flat steel (without seal), 40 x 8 mm, glass bead blasted, 600 mm diameter.	439000	

DG: H, PG: 1	Part no.	Price €
3,000 l	43880.003	
5,000 l	43880.005	
7,000 l	43880.007	
10,000 l	43880.010	
13,000 l	43880.013	
15,000 l	43880.015	
16,000 l	43880.016	
20,000 l	43880.020	
25,000 l	43880.025	
30,000 l	43880.030	
40,000 l	43880.040	
50,000 l	43880.050	
60,000 l	43880.060	
80,000 l	43880.080	
100,000 l	43880.100	

On request

* Please enquire for larger linings and other shapes. Scope of delivery does not include accessories.

i

On request:

- Dimensional drawings for customised inner linings
- Complete tank protection packages
- Training seminars on installation of inner linings and leak detectors

Inner linings AR-S for rainwater harvesting

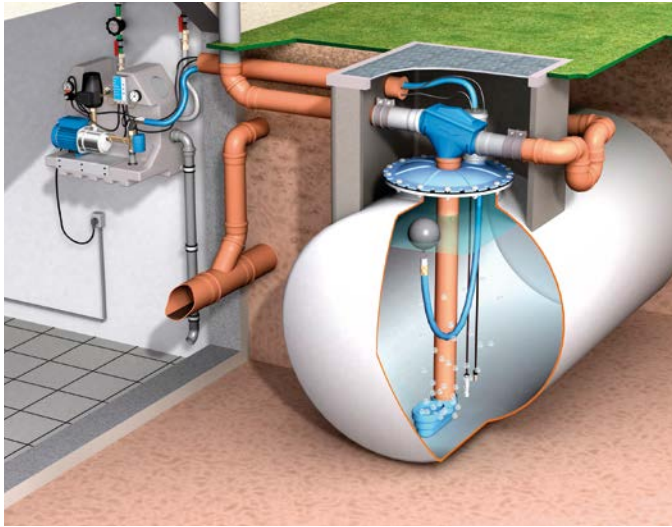

Application

When old heating oil storage tanks are taken out of service, for example due to corrosion, or if the heating system is converted to other types of fuel, the existing tanks can be used to collect rainwater. For integration into a rainwater harvesting system, the tank is cleaned and then fitted with a special inner lining suitable for water. The old, standardised manhole cover (Ø 500 mm) is replaced with a plastic cover specially designed for rainwater harvesting.

Description

Plastic inner linings for rainwater tanks. For hygienic sealing of cylindrical or rectangular tanks to be used in rainwater harvesting systems. Please enquire for inner linings for spherical tanks, cisterns, cesspits and other containers. It is advisable to install a vacuum type leak detector to monitor the rainwater storage tank for tightness, but this is not mandatory in the case of cylindrical tanks.

3

Inner lining for rainwater for cylindrical tanks*

DG: H, PG: 1	Part no.	Price €
3,000 l	43887.003	
5,000 l	43887.005	
7,000 l	43887.007	
10,000 l	43887.010	
13,000 l	43887.013	
15,000 l	43887.015	
16,000 l	43887.016	
20,000 l	43887.020	
25,000 l	43887.025	
30,000 l	43887.030	
40,000 l	43887.040	On request
50,000 l	43887.050	
60,000 l	43887.060	
80,000 l	43887.080	
100,000 l	43887.100	

* Scope of delivery does not include accessories.

Inner lining for rainwater for rectangular tanks *

DG: H, PG: 1	Part no.	Price €
3,000 l	43888.003	
4,000 l	43888.004	
7,000 l	43888.007	
8,000 l	43888.008	
10,000 l	43888.010	
Other sizes		On request

* Scope of delivery does not include accessories.

Other tanks, cisterns, cesspits, etc. can also be sealed and converted to hygienic storage facilities by means of internal linings. Please enquire.

i

See page 61 for accessories, see page 307 for plastic manhole cover.

Rainwater inner lining AR-SM with magnets

3



- Operation without vacuum type leak detector, no pressure, no current
- Easy and fast installation by means of powerful neodymium magnets
- Perfectly fitting, robust PVC lining



Application For conversion of cylindrical steel DIN tanks such as decommissioned fuel oil tanks, diesel tanks or storage tanks into reliable, high-grade rainwater storage tanks. No pressure or flow required. The rainwater inner lining AR-SM with magnets is suitable for storing rainwater in cylindrical steel tanks (3,000 to 50,000 litres).

Please note: In the case of coated steel tanks, verify that the attractive force of the magnets is sufficient.

Description The rainwater inner lining AR-SM with magnets allows owners to convert a decommissioned steel tank into a rainwater storage tank with very little effort.

The rainwater inner lining AR-SM is a PVC lining with flat, round, extremely powerful neodymium magnets welded into lateral and top areas. The lining is reliably held at the inner wall by the magnets - no pressure or power supply are required inside the tank. A tank can be conveniently converted into a rainwater storage tank: First, the tank is measured and then a precisely fitting lining is manufactured. The tank is prepared on the basis of a defined procedure (thorough cleaning of the tank, corrosion checks, etc.); then, a fleece layer is placed on the tank floor for impact protection.

Then the lining is fitted in the steel tank and inflated by means of a blower; if necessary, the final fit is achieved by means of a vacuum pump. When the PVC lining is inflated, the magnets click into place at the inner wall exactly where planned. The fit of the PVC lining is checked and then it is fastened in the manhole by means of a fastening ring. The tank is ready for storing rainwater immediately after the lining and the piping connections have been installed.

Scope of delivery Rainwater inner lining AR-SM, made of plastic film Sikaplan® WP5140-08 black, film thickness 0.8 mm, for closed tanks, with all neodymium magnets welded into the film in the lateral and top areas, with film flange for the standard fastening ring.

i

Not only cylindrical DIN steel tanks, but certain steel tanks with different geometrical shapes can be converted into rainwater storage tanks. Please enquire separately.









i

Depending on the local conditions and on the tank, a fleece lining may be required in the bottom area of the tank as an impact protection. Different dome distances and special dimensions are manufactured at the same conditions.

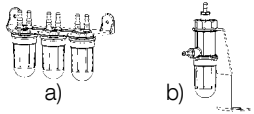
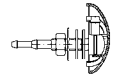
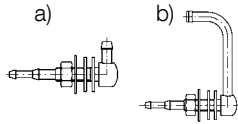
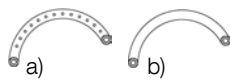
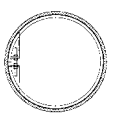
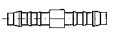
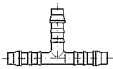
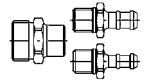
	PG	Part no.	Price €
Extra charge for additional access chamber			
500 mm	1	08027	
600 mm	1	08024	
Accessories (DG: H)			
Fastening ring Ø 500 mm	3	43900A	
Fastening ring Ø 600 mm	3	43900C	
Fleece LSV2 1 x 2 m plate	1	43952	
Bottom plate 800 x 800	1	43894	

DG: H, PG: 1	Part no.	Price €
3,000 l	43889.003	
5,000 l	43889.005	
7,000 l	43889.007	
10,000 l	43889.010	
13,000 l	43889.013	
15,000 l	43889.015	
16,000 l	43889.016	
20,000 l	43889.020	
25,000 l	43889.025	
30,000 l	43889.030	
50,000 l	43889.050	

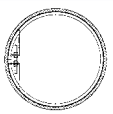
Mounting accessories for inner linings

DG: H	Designation	Specification	PG			Part no.	Price €
	a) Condensate bar	Connections 4/6 mm	1	1	-	43692	
	b) Liquid barrier with condensate trap and fastening bracket	Connections 4/6 mm	1	1	-	43646	
	Angled nipple with spacer	6 x 4/6 mm	2	1	-	43904	
	a) Angled nipple short	6 x 4/6 mm	2	1	25	43906	
	b) Angled nipple long	6 x 4/6 mm	2	1	10	43908	
	a) Suction line perforated (reel 100 m)	6 x 3 mm	1	1	-	43910	
	b) Suction line not perforated (reel 100 m)	6 x 3 mm	1	1	-	43911	
	Fastening ring with round seal, foam rubber	Ø 500 mm	3	1	-	43900A	
		Ø 550 mm	3	1	-	43900B	
		Ø 600 mm	3	1	-	43900C	
		Ø 620 mm	3	1	-	43900D	
	Hose connector for suction hose	4 x 4 mm	1	1	25	43945	
		6 x 6 mm	1	1	25	43912	
	T piece for suction hose	4 x 4 x 4 mm	1	1	25	43944	
		6 x 6 x 6 mm	1	1	25	43913	
	Hose connector kit ND 4/6, G $\frac{3}{8}$ x G $\frac{1}{2}$	ND 4 x G $\frac{1}{2}$ ND 6 x G $\frac{1}{2}$ G $\frac{3}{8}$ x G $\frac{1}{2}$	1	1	25	43914	
	Plate holder	with plate and clamp	3	1	-	43918	
	PVC hose red 100 m	4 x 2 mm	1	1	-	43648	
		6 x 2 mm	1	1	-	43662	
	PVC hose green 100 m	4 x 2 mm	1	1	-	43649	
		6 x 2 mm	1	1	-	43663	
	PVC hose transparent 100 m	4 x 2 mm	1	1	-	43650	
		6 x 2 mm	1	1	-	43664	
	Sealing material 1 kg Glue 0.9 kg	Epple 28	1	1	-	43919	
		Epple 4851	1	1	-	43920	
	Stainless steel fastening ring	V2A flat steel (without seal), 40 x 8 mm, glass bead blasted, 500 mm diameter	3	1	-	43900N	
	Stainless steel fastening ring	V2A flat steel (without seal), 40 x 8 mm, glass bead blasted, 600 mm diameter	3	1	-	43900O	
	Flanges	KT NW 65	3	1	-	44006	
		KT G2	3	1	-	44007	
	Foam rubber roll 10 m	50 x 5 mm	1	1	-	43926	
	Foam rubber roll 10 m	50 x 8 mm	1	1	-	43942	
	Mipoplast bottom plate	800 x 800 mm	1	1	-	43928	

Pressure type leak detector Europress

as per WHG and BetrSichV, EN 13160-1/-2, class I



- With visual and audible alarms, Acknowledge button and switching output
- Pump operating time can be displayed
- Service indicator for annual maintenance
- With power outage monitoring



Europress in protective housing

3



Page 88



Application

Class I pressure type leak detector as per EN 13160-1/-2 for safe monitoring of suitable double-walled tanks for unpressurised storage of numerous water-polluting liquids, also AdBlue® (urea solution 32.5 %). The flexible voltage supply (AC 100–240 V) allows for application in a large variety of countries.

Description

Compact leak detector in a robust wall mounting housing with audible and visual alarms. The audible alarm can be muted with the Acknowledge button. Europress indicates the pump operating time and features a switching output for additional equipment (such as additional alarm unit ZAG 01) or integration into building control systems. The pump operating time can be displayed.

Three hose connections (red, white, green) for the pneumatic connection to the interstitial space of the tank. The universal connection pieces can be used for 4 mm and 6 mm hoses. With condensate trap to protect the electronics. Electrical connection from the top or from the bottom. An optional 9 V battery can be connected so that an alarm is triggered in the case of power outage. For outdoor applications, Europress is available in a protective housing (IP 55).

Alarm units with the EnOcean-ready label can be integrated into your existing building automation systems at a later point in time. To do so, plug the EnOcean® wireless module into the EnOcean® interface (PCB of the device). The AFRISO home gateway in conjunction with additional AFRISO smart home products with EnOcean® wireless technology allow you to configure a whole range of fully customisable, extensible features for the protection of plants and buildings.

Technical specifications

Operating temperature range

Ambient: -5/+50 °C

In protective housing with heating: -25/+50 °C

Supply voltage

AC 100–240 V

Nominal power

< 10 VA

Switching output

Relay contact: 1 voltage-free changeover contact

Contact rating

Max. 250 V, 2 A, resistive load

Operating pressure

Interstitial space: approx. 510 mbar

Housing

Wall mounting housing made of

impact-resistant plastic (ABS)

W x H x D: 202 x 230 x 70 mm

Degree of protection: IP 30 (EN 60259)

Alarm sound

Min. 70 dB(A)

Certification

CE-marking as per EC Construction Products

Regulation 305/2011, EU 574/2014, EN 13160-1/-2

and ÜHP



Drying filter TF 220

PU: 1	DG	PG	Part no.	Price €
Europress	H	4	43790	
Europress in protective housing (IP 55) with horn	H	4	43795	
Europress in protective housing (IP 55) with horn and heating	H	4	43796	
Europress with filter, pipe clamp PG42 and drying beads	H	4	43701	
Mounting kit	H	1	43704	
Drying filter TF 220 with pipe clamp PG42	H	1	43688	
Drying beads, 850 ml	H	1	69226	
Connection piece G1 x ND 4/6 mm	H	1	43698	
EnOcean® wireless module TCM 320	G	4	78082	



Gas detectors



Oil and water Alarm units



Signalling devices

Alarm units, probes and signalling devices

OVERVIEW

WATCHDOG-LINE alarm units for fast detection	66
Alarm units at a glance	68
Industrial alarm units	88

ALARM UNITS FOR OIL/WATER

Oil/water alarm unit ÖWWG 3	71
Oil/water alarm unit ÖWWG 3 with burner connection kit	72
Oil/water alarm unit OM 5	73
Water alarm unit for separate detection of oil and water ÖWU	74
Oil-on-water detector ÖAWD-8	75

ALARM UNITS FOR OIL

Fuel oil alarm unit HMS	76
--------------------------------	----

ALARM UNITS FOR WATER

Water alarm unit WWG	77
Leak detectors CoFox® ELT 500/4, ELT 8	78

ALARM UNITS FOR GAS

Gas alarm unit GS 1.1	79
Gas alarm unit GS 2.1 , external gas sensor GS 4.1	80
Gas detector GM 2.1	81
Gas sensors GS 4.1 for GM 2.1	82
Test gas bag PGT 10	82

ACCESSORIES

Floor water probe BWS 10-1 , wall mounting rail probe WSS , floating probe SWS	83
PTC thermistor probe, photoelectric probe, EnOcean® wireless module TCM 320	84
Drip pan, mounting frame, seal kit IP 54, DIN rail clip	85

SIGNAL PROCESSING

Signalling devices: combined warning light and horn WLH 1 , horn KH 1	86
Signalling devices: horn HPW 2 , warning light with rotating reflector SLD 1	87
Additional alarm unit ZAG 01 for alarm units	88

Alarm units for fast detection of levels, accumulations of liquids, leakage, gases or smoke

WATCHDOG-LINE – for maximum safety

4

- 1 Oil/water alarm unit OM 5 with EnOcean® wireless module TCM 320 for integration into smart home systems
- 2 Photoelectric probe for tank room monitoring
- 3 Photoelectric probe with drip pan
- 4 Wireless smoke alarm Funk ASD 10
- 5 Digital tank contents indicator DTA 20 E (wireless)



In the building technology sector, there are many risks which should be monitored to avoid annoyance to home owners, janitors, property managers or maintenance personnel and to avert extensive damage. WATCHDOG-LINE alarm units report undesirable events, danger and emergency conditions early so that immediate measures can be taken.

The WATCHDOG-LINE devices excel with easy and intuitive operation. A large variety of probes and sensors enable fast detection of liquid levels, leakage and accumulations of liquids, gases or smoke. Integrated visual and audible alarms provide the appropriate signals in hazard conditions. For remote signalling and easy

integration into AFRISO smart home systems, the devices are ready for the installation of an EnOcean® wireless module. This way, the persons in charge can be notified of an alarm condition - whether or not they have a mobile device. Residential buildings, factories and facilities are protected and monitored.

From standard wall mounting to integration into control cabinets using mounting frames – WATCHDOG-LINE alarm units are easy and quick to install. With very little effort, the devices can also be retrofitted with seal kits for use in rough dirty and wet environments (IP 54).

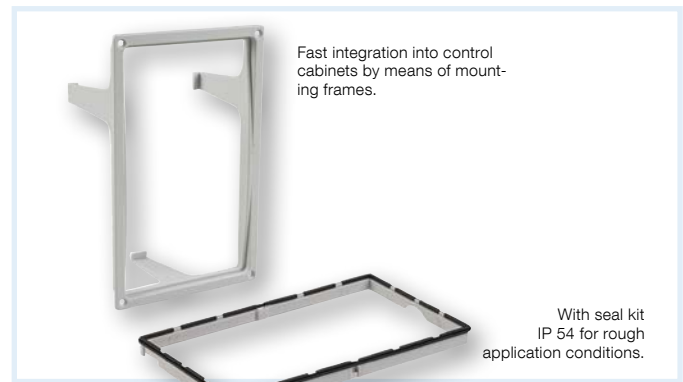

WATCHDOG-LINE alarm units



- Audible and visual alarms for maximum safety
- Additional signalling devices (ZAG 01, horn, warning light) can be connected
- Ready-to-connect device for easy installation and commissioning
- High reliability and long service life



4

Typical application areas







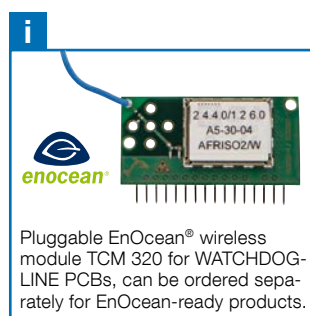



























- Collection facilities below oil and water consuming equipment
- Drip pans below storage tanks, burners or motors in buildings or outdoors
- Containers, barrels and tanks/ double-walled tanks
- Sewage tanks
- Cisterns and water storage tanks
- Drinking water installations
- Oil depots, boiler rooms and rooms with mains water connection
- Heating systems
- Cable and pipe ducts
- Canal shafts, manholes and inspection ducts
- Cellars, kitchens, laundry rooms
- Warehouses and storage areas
- Machinery rooms
- Museums, archives, office buildings
- Lift shafts
- High-tech equipment rooms and server rooms
- Pumping stations and control rooms
- Catchment and overflow basins
- Flood hazard areas
- Oil, petrol and grease separators
- Protective pipes and pipelines

Detectable media





















- Water, waste water, groundwater
- Heating circuit water
- Cooling water
- Rainwater
- Fuel oil EL, L, M
- Diesel fuels or low-viscosity lubricating oils class A III
- Motor oils, gearbox oils and hydraulic oils
- Vegetable oils and transformer oils
- Beverages
- Antifreeze agents and fertilisers
- Emulsions
- Sludge, sand
- Oil, petrol and grease layers
- Conductive water mixtures and liquids
- Gases, vapours, smoke
- Many other liquids with a flash point of > 55 °C

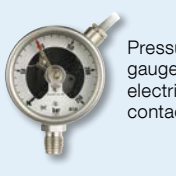

WATCHDOG-LINE alarm units at a glance

Alarm unit	Probe	Media	Application	Catalogue page
 <p>Water alarm unit WWG</p> 	Wall mounting rail probe WSS  or  Floor water probe BWS 10-1	<ul style="list-style-type: none"> Water Conductive water mixtures Electrically conductive liquids Emulsions 	<p>Single-channel Suitable for water, but also for electrically conductive liquids, emulsions and conductive water mixtures.</p> <p>EnOcean®-ready</p>	 Page 77
 <p>Oil/water alarm unit ÖWU</p> 	 Wall mounting rail combination probe	<ul style="list-style-type: none"> Oil + water 	<p>Single-channel ÖWU distinguishes oil alarms and water alarms and indicates the appropriate alarm condition.</p> <p>EnOcean®-ready</p>	 Page 74
 <p>Oil/water alarm unit ÖWWG 3</p> 	 PTC thermistor probe	<ul style="list-style-type: none"> Electrically conductive and non-conductive liquids 	<p>Single-channel ÖWWG 3 generates alarms in the event of accumulations of liquids caused by tank leaks, backflow, flooding, etc. EnOcean®-ready</p> <p>Certificate: DIBt: Z-65.40-339</p>	 Page 71
 <p>Oil-on-water detector ÖAWD ÖAWD-8</p> 	 Floating probe SWS	<ul style="list-style-type: none"> Oil on water 	<p>Single-channel ÖAWD monitors standing water and calmly flowing bodies of water / water surfaces for pollution by oil.</p>	 Page 75
 <p>Oil/water alarm unit OM 5*</p> 	 Photoelectric probe	<ul style="list-style-type: none"> Oil Water 	<p>5 channels For collection facilities below oil consuming equipment, pipe and cable ducts, pumps and control stations and tanks.</p> <p>Certificate: DIBt: Z-65.40-214</p>	 Page 73
 <p>Digital tank contents indicator DTA 10/ DTA 20 E</p> 	 Pneumatic measuring line	<ul style="list-style-type: none"> Fuel oil Diesel fuel Water Non-corrosive media (density 0.5 to 1.5 g/cm³) 	<p>Single-channel For manual level measurement and signalling of a minimum level during measurements – battery-operated.</p> <p>DTA 20 E EnOcean® inside</p>	 Page 12 and Page 100
 <p>Level indicator TankControl 10</p> 	 or  Submersible probe or Magnetic float switch	<ul style="list-style-type: none"> Fuel oil EL, L Diesel fuel Biodiesel Water 	<p>Single-channel/dual-channel For continuous level measurement and alarms in the event of minimum or maximum levels, level differences, backwater and level control.</p>	 Page 14
 <p>Level switches Minimelder / Maximelder</p> 	 Magnetic float switch	<ul style="list-style-type: none"> Water Fuel oil EL, L, M Oil/water mixtures Neutral liquids 	<p>Single-channel Suitable to signal minimum or maximum levels in tanks containing liquids.</p> <p>EnOcean®-ready</p>	 Page 19

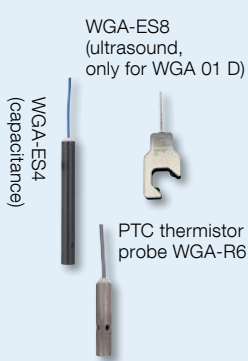
* Use as leak detection system class III as per EN 13160-1/-4.

Alarm unit	Probe	Media	Application	Catalogue page
 Backup controller RENA	 Level probe	<ul style="list-style-type: none"> ▪ Rainwater 	Single-channel Controls backup supply of mains water if the rainwater level is low.	 Page 309
 Water valve WaterControl 01.1	 WaterSensor con Water Sensor BWS WaterSensor eco Battery-less	<ul style="list-style-type: none"> ▪ Water ▪ Rainwater 	Multi-channel For manually or remotely controlled closing and opening of a water pipe in the case of a leak. Teach-in of up to 40 sensors. EnOcean®-inside	 Page 98
 Overfill prevention system UFS 01 according to WHG	 Level probe Type 76 A	<ul style="list-style-type: none"> ▪ Water-polluting liquids (flash point > 55 °C) 	Single-channel Signals when the maximum level in stationary tanks is reached. Certificate: DIBt: Z-65.11-193	 Page 39
 Leak detector LAG as per German WHG and BetrSichV	 Leak detection fluid container with probe	<ul style="list-style-type: none"> ▪ Water-polluting liquids 	Single-channel Leak detector for double-walled tanks with liquid in the interstitial space. Certificate: CE marking as per EU Construction Products Regulation 305/2011, EU 574/2014, EN 13160-1,-3 and ÜHP	 Page 49
 Gas detector GM 2.1	 Gas sensor GS 4.1	<ul style="list-style-type: none"> ▪ Explosive gases ▪ Vapours 	Dual-channel Suitable for monitoring rooms, buildings and public facilities.	 Page 81
 Alarm unit for low gas level	 Pressure gauges with electrical contacts	<ul style="list-style-type: none"> ▪ Gases 	Single-channel Alarm unit for low gas level for monitoring the pressure in gas-filled containers.	 Page 117
 Alarm units WGA for separators	 WGA-ES8 (ultrasound, only for WGA 01 D) WGA-ES4 (capacitance) PTC thermistor probe WGA-R6	<ul style="list-style-type: none"> ▪ Oil ▪ Petrol ▪ Grease ▪ (Sludge, sand) 	Devices with 1 channel / 2 channels / 3 channels Monitor, for example, the layer thickness and the maximum level of separated liquid in oil, petrol and grease separators.	 Page 336

Application examples WATCHDOG-LINE alarm units

4

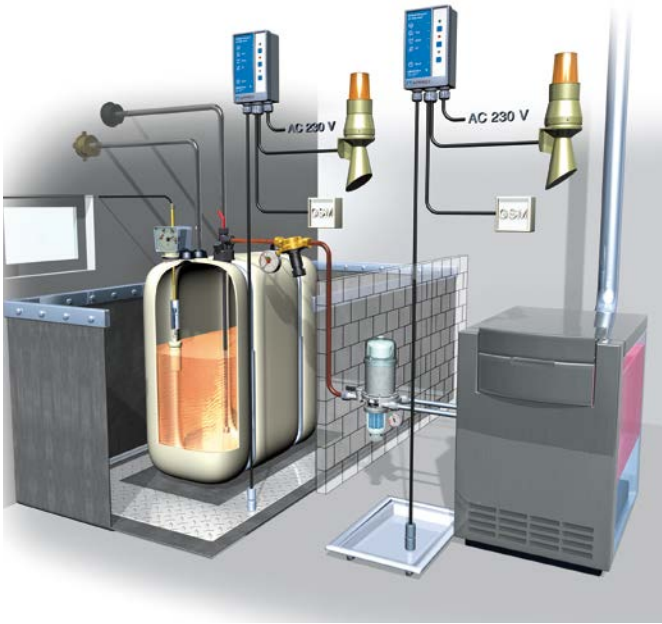

Leak detection in tank and heating rooms with ÖWWG 3.



When the maximum level in the catchment basin is reached, the WWG alarm unit controls the draining process by means of a connected pump.



AFRISO Smart Home: Monitoring and control of domestic equipment, apartments and buildings for function and leaks with the AFRISOhome gateway. Interconnected sensors, actuators and alarm units increase safety and convenience. Application examples: Heating systems, laundry rooms, basements, utility rooms and drinking water installations.



Warning system (water leaks, flooding) for complete buildings with central alarm CoFox®.

Oil/water alarm unit ÖWWG 3

Class III, EN 13160-1, -4



- For storage rooms, manholes, drip pans
- With visual/audible alarms, Test/Acknowledge buttons and relay output
- Self-monitoring probe
- EnOcean®-ready

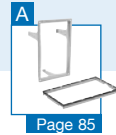

4

Applications For visual and audible alarms of liquids with a flash point of $> 55\text{ °C}$ are detected in, for example, oil storage rooms, drip pans, inspection ducts, ducts, protective pipes, manholes, pipes and cellars, however, not in wet rooms and humid rooms. Suitable for the following media: water, fuel oil, diesel fuel or low-viscosity lubricating oils, motor oils, hydraulic oils, vegetable oils and transformer oils, antifreeze agents, oil-water mixtures and emulsions. Use as leak detection system class III as per EN 13160-1/-4 and as leak detection system as per TRWS 791-1/-2.

Description The oil/water alarm unit in a wall mounting housing triggers visual and audible alarms in the event of accumulations of liquids which can be caused by tank leaks, backflow, flooding, etc. ÖWWG 3 consists of a control unit with visual/audible alarm, Test and Acknowledge buttons as well as a flexible PTC thermistor probe. The probe is mounted at the lowest point of the area to be monitored. Alarm is triggered when there is contact with escaped liquid. The audible alarm can be muted with the Acknowledge button. The visual alarm remains active until the leak has been removed. The Test button allows you to simulate an alarm condition in order to perform a function check. The self-monitoring probe triggers an alarm if it is damaged. The voltage-free relay contact is provided for connection of additional alarm equipment (such as additional alarm unit ZAG 01). ÖWWG 3 is suitable for panel mounting with a mounting frame. A sealing kit (IP 54) is available for rough application conditions. Alarm units with the EnOcean-ready label can be integrated into your existing building automation systems, for example, AFRISO smart home, at a later point in time. To do so, plug the EnOcean® wireless module into the EnOcean® interface (PCB of the device).

Technical specifications

Operating temperature range

Ambient: $-5/+40\text{ °C}$

Probe

L x Ø: 57 x 14 mm

Cable length: 3.2 m or 10 m

Supply voltage

AC 100–240 V or AC/DC 15–40 V

Nominal power

10 VA

Switching output

Relay contact: 1 voltage-free changeover contact

Alarm sound

Min. 70 dB (A)

Housing

Wall mounting housing made of impact-resistant plastic (ABS)
W x H x D: 100 x 188 x 65 mm
Degree of protection: IP 30 (EN 60529)

Certificate

DIBt: Z-65.40-339

Scope of delivery

- Control unit
- PTC thermistor probe
Part no. 44510/44488: 3.2 m
Part no. 44494: 10 m

Option

- EnOcean® wireless module (can be retrofitted)

DG: G, PG: 4		Probe length	Part no.	Price €
Oil/water alarm unit ÖWWG 3	AC 100–240 V	3.2 m	44510	
		10 m	44494	
	AC/DC 15–40 V	3.2 m	44488	
Spare probe ÖWWG 3, length 3.2 m, year of manufacture 09/2013 and later			44516	
Spare probe ÖWWG 3, length 10 m, year of manufacture 09/2013 and later			44484	
Spare probe ÖWWG 3, length 25 m, year of manufacture 09/2013 and later			44482	
Spare probe ÖWWG 3, length 3.2 m, up to year of manufacture 08/2013			44481	
Probe fuse			44495	
Mains fuse			10820	
EnOcean® wireless module TCM 320			78082	

Oil/water alarm unit ÖWWG 3 with burner connection kit



- Connection pre-wired
- With visual/audible alarms, Test and Acknowledge buttons
- Automatic switching off of the burner in alarm conditions
- EnOcean®-ready



4



Application For visual and audible alarms in the event of accumulations of liquids below the burner of an oil fuelled system and for switching off the burner in alarm conditions. Suitable for the following media: water, fuel oil and diesel fuel.

Description The ÖWWG 3 oil/water alarm unit consists of a control unit with visual/audible alarm, Test and Acknowledge buttons as well as a flexible PTC thermistor probe. Cable and connector for connection of burner and boiler are fully wired and ready to be connected. In the event of an alarm, the unit triggers visual and audible alarms and switches off the burner. The audible alarm can be muted with the Acknowledge button. The visual alarm remains active until the leak has been removed. The burner then resumes operation. The Test button allows you to simulate an alarm condition in order to perform a function test. Alarm units with the EnOcean-ready label can be integrated into your existing building automation systems, for example, AFRISO smart home, at a later point in time. To do so, plug the EnOcean® wireless module into the EnOcean® interface (PCB of the device). The AFRISOhome gateway in conjunction with additional AFRISO smart home products with EnOcean® wireless technology allow you to configure a whole range of fully customisable, extensible features for the protection of plants and buildings.

Technical specifications

Operating temperature range

Ambient: -5/+40 °C

Probe

L x Ø: 57 x 14 mm
Cable length: 3.2 m

Connector

Burner: 7-pin, female with 3 m cable
Boiler: 7-pin, male, with 3 m cable

Supply voltage

AC 230 V

Nominal power

10 VA

Alarm sound

Min. 70 dB(A)

Housing

Wall mounting housing made of impact-resistant plastic (ABS)
W x H x D: 100 x 188 x 65 mm
Degree of protection: IP 30 (EN 60529)

Certificate

DIBt: Z-65.40-339

Scope of delivery

- Control unit
- 1 connected PTC thermistor probe
- One connected plug each for burner and boiler connection

Option

- EnOcean® wireless module (can be retrofitted)

DG: G, PG: 4	Part no.	Price €
Oil/water alarm unit ÖWWG 3 With burner connection kit	44490	
EnOcean® wireless module TCM 320	78082	

Oil/water alarm unit OM 5

Class III, EN 13160-1, -4



- For storage rooms, manholes, drip pans, double-walled tanks
- With visual/audible alarms, Test/Acknowledge buttons and relay output
- Self-monitoring probe

Monitors up to 5 tanks

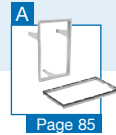

4

Application For visual and audible alarms if liquids with a flash point of $>55\text{ }^{\circ}\text{C}$ are detected. OM 5 is suitable for the following media: Fuel oil, diesel fuel or low-viscosity lubricating oils, motor oils, gearbox oils or hydraulic oils, vegetable oils and transformer oils, water and other liquids. Use as leak detection system class III as per EN 13160-1/-4 and as leak detection system as per TRWS 791-1/-2.

Description The unit in a wall mounting housing triggers visual and audible alarms in the event of accumulations of liquids which can be caused by tank leaks, backflow, flooding, etc. OM 5 consists of a control unit with visual/audible alarm, Test and Acknowledge buttons as well as a relay output. Up to five photoelectric probes can be connected. The probes are mounted at the lowest point of the object to be monitored. Alarm is triggered when there is contact with escaped liquid. The audible alarm can be muted with the Acknowledge button. The visual alarm is cleared once the leak has been fixed. The Test button allows you to simulate an alarm condition in order to perform a function test. The voltage-free relay contact is provided for connection of additional alarm equipment (such as additional alarm unit ZAG 01, horn). The alarm units are suitable for panel mounting with a mounting frame. A sealing kit (IP 54) is available for rough application conditions.

Empty probe for retrofitting of photoelectric probes in battery tanks.

OM 5/1 with additional probe for detection of minimum levels, e.g. in fuel oil tanks.

Technical specifications

Operating temperature range

Ambient: $-10/+60\text{ }^{\circ}\text{C}$

Probe

L x \varnothing : 33 x 10 mm
Cable length: 10 m

Supply voltage

OM 5: AC 230 V or AC/DC 24 V
OM 5/1: AC 230 V

Nominal power

5 VA

Switching output

Relay contact: 1 voltage-free changeover contact

Alarm sound

Min. 70 dB(A)

Housing

Wall mounting housing made of impact-resistant plastic (ABS)
W x H x D: 100 x 188 x 65 mm
Degree of protection: IP 30 (EN 60529)

Certificate

DIBt: Z-65.40-214

Scope of delivery

- OM 5: ■ Control unit without probe
OM 5/1: ■ Control unit
■ 1 photoelectric probe
■ 1 floating probe

i

Please order the photoelectric probes separately.

DG: G, PG: 4	Part no.	Price €
Oil/water alarm unit OM 5	44502	
Oil/water alarm unit OM 5, 24 V	44486	
Oil/water alarm unit OM 5/1	44517	
Photoelectric probe 10 m	44503	

Oil/water alarm unit ÖWU



- Combination probe for determination of leaking medium oil and water
- For storage rooms, manholes, drip pans and pumps
- With fail-safe mode
- With visual/audible alarms, Test/Acknowledge buttons and relay output

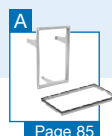

4

Application For visual and audible alarms if liquids with a flash point of > 55 °C are detected. Suitable for the following media: water, fuel oil, diesel fuel or low-viscosity lubricating oils, motor oils, gearbox oils or hydraulic oils, vegetable oils and transformer oils.

Description Alarm unit in wall mounting housing for early detection of accumulations of liquids. ÖWU consists of a control unit with visual/audible alarm, Test and Acknowledge buttons, two relay outputs as well as a combination probe with photoelectric and conductivity sensors. An integrated microprocessor determines whether the detected medium is oil or water. The probe is mounted at the lowest point of the object to be monitored. Alarm is triggered when there is contact with escaped liquid. The audible alarm can be muted with the Acknowledge button. The visual alarm is cleared once the leak has been removed. The Test button allows you to simulate an alarm condition in order to perform a function test. The two voltage-free relay contacts are provided for connection of additional external alarm equipment or additional alarm units; e.g. 1 relay for water alarm and 1 relay for oil alarm. ÖWU features a "fail-safe" mode. The alarm units are suitable for panel mounting with a mounting frame. A sealing kit (IP 54) is available for rough application conditions.

Alarm units with the EnOcean-ready label can be integrated into your existing building automation systems, for example, AFRISO smart home, at a later point in time. To do so, plug the EnOcean® wireless module into the EnOcean® interface (PCB of the device). The AFRISOhome gateway in conjunction with additional AFRISO smart home products with EnOcean® wireless technology allow you to configure a whole range of fully customisable, extensible features for the protection of plants and buildings.

Technical specifications

Operating temperature range

Medium: 5/50 °C
Ambient: -10/+60 °C

Wall mounting rail probe

W x H x D: 40 x 300 x 55 mm
Standard probe cable: 1.5 m

Supply voltage

AC 100–240 V

Nominal power

6 VA

Switching output

1 voltage-free changeover contact (water alarm)
1 changeover contact (oil alarm)

Switching over

Eco mode/fail-safe mode

Contact rating

Max. AC 250 V, 2 A

Alarm sound

Min. 70 dB(A)

Housing

Wall mounting housing made of impact-resistant plastic (ABS)
W x H x D: 100 x 188 x 65 mm
Degree of protection: IP 30 (EN 60529)

Scope of delivery

- Control unit
- Wall mounting rail probe WSS

Option

- EnOcean® wireless module (can be retrofitted)

DG: G, PG: 4	Part no.	Price €
Oil/water alarm unit ÖWU	40028	
EnOcean® wireless module TCM 320	78082	

Oil-on-water detector ÖAWD-8



- For the detection of oil layers on water
- Alarm unit on conductivity principle
- With visual alarm, Test and Unlock pushbuttons
- Relay output for additional alarm



4

Application For visual and audible alarms in the event of oil layers on water. Especially suitable for catchment basins, floods and inspection ducts.

Description Alarm unit in wall mounting housing for the detection of oil layers on water. ÖAWD consists of a control unit with visual/audible alarm, Test/Unlock buttons as well as a relay output. ÖAWD is based on the conductivity principle. The floating probe SWS is used for detection. If an oil layer (of at least 2 mm) is detected, the alarm unit triggers a visual alarm and stores the alarm condition. Once the cause of the alarm condition has been removed, press the Unlock button to reset ÖAWD. The visual alarm is deactivated. The Test button allows you to simulate an alarm condition in order to perform a function test. The voltage-free relay contact is provided for connection of additional signalling equipment (such as ZAG 01), actuators (pumps, valves), additional alarm units or event reporting systems. The alarm units are suitable for panel mounting with a mounting frame. A sealing kit (IP 54) is available for rough application conditions. ÖAWD-8 is available for applications with turbulent surfaces; this version features a delay of approx. 8 s which helps to avoid false alarms.

Technical specifications

Operating temperature range

Medium: 0/50 °C
Ambient: 0/55 °C

Probe SWS

2-rod electrode, encapsulated cable connection
W x H x D: 200 x 140 x 200 mm
Cable length: 10 m
Adjustment range: 2/10 mm oil layer thickness
Also suitable for changing levels

Supply voltage

AC 100–240 V

Nominal power

5 VA

Switching output

Relay output: 1 voltage-free changeover contact

Contact rating

AC 250 V, 2 A

Response delay

ÖAWD-8: 8 s

Housing

Wall mounting housing made of impact-resistant plastic (ABS)
W x H x D: 100 x 188 x 65 mm
Degree of protection: IP 30 (EN 60529)

Scope of delivery

- Control unit without probe

DG: H, PG: 4			Part no.	Price €
Oil-on-water detector ÖAWD-8	1	-	55105	
Floating probe SWS	1	-	55100	

Fuel oil alarm HMS in connector housing



- Immediate switching off of monitored devices in the event of a leak alarm
- With visual alarm
- Ready-to-connect device for fast and easy installation



4

Application For the detection of oil in drip pans below oil-consuming systems, oil pumps, pumping or control stations. Suitable for the following media: water, fuel oil, diesel fuel, motor oils, machine oils, hydraulic oils and similar. Liquids with a flash point of > 55 °C.

Description The HMS fuel oil alarm unit consists of a transducer and a photoelectric probe. Devices to be monitored are connected directly to the socket of the transducer. If there is no leak, the green lamp is on. If the probe detects unwanted liquid, the alarm unit triggers a visual alarm (red lamp) and the socket in the transducer is automatically switched off.

Technical specifications

Operating temperature range
Ambient: -10/+60 °C

Photoelectric probe
Probe head: Polyamide
Cable: 2 m

Supply voltage
AC 230 V

Visual indication
Green lamp Operation
Red lamp Alarm

Housing
Connector housing
W x H x D: 65 x 120 x 92 mm
Degree of protection: IP 20 (EN 60529)

Certificate
DIBt: Z-65.40-214

Scope of delivery

- Transducer
- Photoelectric probe with 2 m probe cable
- Bracket for probe with mounting accessories

DG: G, PG: 4	Part no.	Price €
Fuel oil alarm unit HMS	44513	

Water alarm unit WWG



- Ideal for laundry rooms, cellars/storage rooms, pump and inspection ducts
- With visual/audible alarms, Test and Acknowledge buttons and 2 relay outputs
- With floor probe or wall mounting rail probe
- EnOcean®-ready

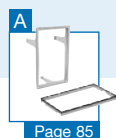

4

Application For visual and audible alarms in the event of accumulations of electrically conductive liquids such as rainwater, tap water, fresh water, waste water, cooling water and heating water.

Description Alarm unit in wall mounting housing for the detection of even the smallest amounts of water caused by, for example, backflow due to clogged water pipes, water ingress from outdoors, broken pipes or failure of a waste water pump. WWG 1 consists of a control unit with visual/audible alarm, Test and Acknowledge buttons, two relay outputs as well as a special floor probe. The probe is mounted at the lowest point of the object to be monitored. Alarm is triggered when there is contact with escaped liquid. The audible alarm can be muted with the Acknowledge button. The visual alarm is cleared once the leak has been removed. The Test button allows you to simulate an alarm condition in order to perform a function test.

The two voltage-free relay contacts are provided for connection of additional external alarm equipment or alarm units. One relay can be acknowledged (e.g. for an external horn), the other relay cannot (e.g. for an external lamp, a solenoid valve, a pump). The alarm units are suitable for panel mounting with a mounting frame. A sealing kit (IP 54) is available for rough application conditions.

Alarm units with the EnOcean-ready label can be integrated into your existing building automation systems, for example, AFRISO smart home, at a later point in time. To do so, plug the EnOcean® wireless module into the EnOcean® interface (PCB of the device). The AFRISOhome gateway in conjunction with additional AFRISO smart home products with EnOcean® wireless technology allow you to configure a whole range of fully customisable, extensible features for the protection of plants and buildings.

Water alarm unit WWG 2 like WWG 1, but with height-adjustable wall mounting rail probe.

Technical specifications

Operating temperature range

Ambient: -5/+55 °C

Floor probe BWS 10-1

Response level approx. 2–3 mm
Dimensions Ø 70 mm

Wall mounting rail probe WSS

Height-adjustable by approx. 200 mm
W x H x D: 37 x 320 x 55 mm

Standard probe cables

1.5 m, max. length 50 m (shielded)

Function principle

Conductivity measurement

Supply voltage

AC 100–240 V

Nominal power

2.5 VA

Switching output

1 voltage-free changeover contact
1 voltage-free normally open contact
(can be acknowledged)

Contact rating

Max. AC 250 V, 2 A

Alarm sound

Min. 70 dB(A)

Housing

Wall mounting housing made of impact-resistant plastic (ABS)
W x H x D: 100 x 188 x 65 mm
Degree of protection: IP 30 (EN 60529)

Scope of delivery

- Control unit
- Floor probe BWS 10-1 (for WWG 1)
- Wall mounting rail probe WSS (for WWG 2)

Option

- EnOcean® wireless module (can be retrofitted)

DG: G, PG: 4	Part no.	Price €
Water alarm unit WWG1	40029	
Water alarm unit WWG 2	40031	
EnOcean® wireless module TCM 320	78082	

Leak detectors CoFox® ELT 500/4, ELT 8



4

Application For the detection of electrically conductive liquids such as water, emulsions or waste water.

Alarm unit CoFox® ELT 500/4

Description Alarm unit in wall mounting housing with visual alarm, operation indicator, reset button and relay output for additional external signalling equipment or the additional alarm unit ZAG 01. A total of 4 probe circuits can be connected. Leak location by means of LEDs. When the probe comes into contact with liquid, The alarm is triggered and the connected alarm equipment is activated. The alarm can be acknowledged with the Reset button. ELT 500/4 features four channels for separate probe circuits so that several probes can be operated in parallel or cascading for large-area monitoring is possible.

Technical specifications

- Operating temperature range**
Ambient: -10/+50 °C
- Response threshold**
50 kOhm
- Switching output**
Relay output: 1 voltage-free changeover contact
- Visual indication**
Green LED: Mains operation
4 red LEDs: Alarm condition
- Supply voltage**
AC 230 V
- Probe connections**
4 probe circuits
- Contact rating**
Max. AC 250 V, 2 A
- Nominal power**
3 VA
- Housing**
Wall mounting plastic housing
W x H x D: 53 x 113 x 108 mm
Degree of protection: IP 30 (EN 60529)

Water alarm unit CoFox® ELT 8

Water alarm unit in wall mounting housing with visual alarm, operation indicator as well as two relay outputs for additional external signalling equipment or the additional alarm unit ZAG 01. The probe is mounted at the lowest point of the object to be monitored. The alarm is triggered when the probe comes into contact with liquid and ELT 8 activates the connected alarm equipment. The visual alarm is cleared once the leak has been removed. ELT 8 enables parallel operation of several probes.

- Operating temperature range**
Ambient: -10/+60 °C
- Response threshold**
Fully adjustable, 2.5 kOhm – 60 kOhm
- Switching output**
Relay output: 2 voltage-free changeover contacts
- Visual indication**
Green LED: Mains operation
Red LED: Alarm condition
- Supply voltage**
AC 230 V or DC 24 V
- Probe connections**
1 probe circuit (several probes can be connected in parallel)
- Contact rating**
Max. AC 250 V, 2 A
- Nominal power**
4 VA (230 V) / 2 VA (24 V)
- Housing**
W x H x D: 53 x 113 x 108 mm
Degree of protection: IP 30 (EN 60529)

i See page 83 for probes. See the catalogue INDUSTRIAL TECHNOLOGY for additional information on CoFox® ELT 500/4 and ELT 8.

DG: H, PG: 4	Part no.	Price €
Alarm unit CoFox® ELT 500/4*	53505	
Water alarm unit CoFox® ELT 8*	230 V	53503
	24 V	53503A

* Please order probes separately.

Gas alarm unit GS 1.1



- For private homes
- Detection of, for example, natural gas (methane) and liquefied gas (propane, butane) in ambient air and generation of gas alarm

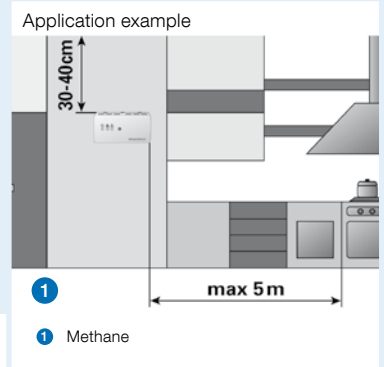

Application For the detection of flammable gases such as methane, propane, butane in ambient air in residential buildings.

Description Gas alarm unit with integrated semiconductor sensor and alarm buzzer. LEDs for operation (green), alarm (red), error (yellow), the Test button and the Reset button are located at the front side of the housing. The alarm is triggered when approx. 20 % of the lower explosion limit (LEL) is reached. The audible alarm can be muted with the Reset button. The visual alarm remains active until the alarm condition no longer exists (reset).

Technical specifications

Supply voltage

AC 230 V

Housing

W x H x D: 158 x 90 x 44 mm
Degree of protection: IP 20 (EN 60529)

Operating temperature range

Ambient: 0/50 °C; max. 75 % r.h.

Alarm value

Approx. 20 % LEL

Alarm tone

Internal buzzer, min. 50 dB(A)

Service life

Approx. 5 years

i

GS gas alarm units are cross-sensitive to hydrocarbons, lacquers, solvents, alcohols and similar media.

DG: H, PG: 4			Part no.	Price €
Gas alarm unit GS 1.1 Methane	1	-	61184	
Gas alarm unit GS 1.1 Propane/Butane	1	-	61186	

Gas alarm units for the private home

With relay
for external
Sensor



4

Gas alarm unit GS 2.1

Application For the detection of flammable gases such as methane, propane, butane in ambient air in residential buildings.

Description Gas alarm unit with integrated semiconductor sensor, alarm buzzer and relay output for connection of additional external alarm equipment (e.g. horn, warning light). LEDs for operation (green), alarm (red), error (yellow), the Test button and the Reset button are located at the front side of the housing. The alarm is triggered when approx. 20 % of the LEL (lower explosive limit) is reached. The audible alarm can be muted with the Reset button. The visual alarm remains active until the alarm condition no longer exists (reset). The unit features an additional input for connection of an external gas sensor GS 4.1 as a second measuring point, e.g. for monitoring different rooms.

Technical specifications

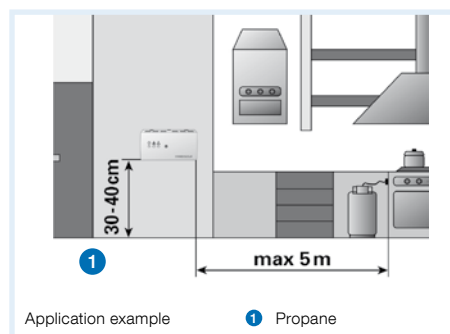

Supply voltage: AC 230 V

Housing

W x H x D: 158 x 90 x 44 mm
Degree of protection: IP 20 (EN 60529)

Operating temperature range

Ambient: 0/50 °C; max. 75 % r.h.

Alarm value: Approx. 20 % LEL

Audible alarm: Internal buzzer, min. 50 dB(A)

Service life: Approx. 5 years

External gas sensor GS 4.1

Additional gas sensor to be used with the gas alarm unit GS 2.1. Enables monitoring at two points in different rooms.

Remote probe for gas alarm unit GS 2.1. Audible alarm is triggered by the gas alarm GS 2.1.

Detectable gases: Methane, propane, butane. LEDs at the sensor indicate the operating and alarm state of the gas alarm system:

- LED green: Operation
- LED yellow: Error
- LED red: Gas alarm

Measured gas

Flammable gases and vapours in ambient air.

Measuring range

0–50 % LEL

Measuring principle

Semiconductor (service life approx. 5 years, depending on the operating conditions)

Supply voltage: Via GS 2.1

Housing

W x H x D: 80 x 80 x 36 mm
Degree of protection: IP 20 (EN 60529)

Operating temperature range

Ambient: 0/50 °C
max. 75 % r.h.

Alarm value: Approx. 20 % LEL

Service life: Approx. 5 years

i

GS gas alarm units and sensors are cross-sensitive to hydrocarbons, lacquers, solvents, alcohols and similar media.

DG: H, PG: 4			Part no.	Price €
Gas alarm unit GS 2.1 Methane	1	-	61185	
Gas alarm unit GS 2.1 Propane/Butane	1	-	61187	
Gas sensor GS 4.1 Methane	1	-	61188	
Gas sensor GS 4.1 Propane/Butane	1	-	61189	

Gas detector GM 2.1



- For early detection of natural gas (methane) and liquefied gas (propane, butane)
- Audible and visual alarms, Acknowledge button and relay output
- Self-monitoring for line interruption, short circuit and sensor defect



Application For continuous monitoring for explosive gases and vapours and for generating alarms in conjunction with the appropriate sensors. GM 2.1 is installed in heating rooms and basements, storage, office and residential buildings to increase safety. Not suitable for installation in hazardous areas (EX areas).

Description Alarm unit in a wall mounting housing with audible and visual alarms. GM features an alarm threshold and is equipped with a relay contact. If the threshold value is exceeded, the unit generates an alarm. The red LED lights up, the audible alarm goes off and the alarm relay switches. The audible alarm can be muted with the Acknowledge button. When the alarm condition no longer exists, you press the Acknowledge button again to clear the visual alarm (alarm memory). The alarm can only be cleared with the Acknowledge button if the cause of the alarm has been removed. If the concentration still exceeds the alarm threshold, pressing the Acknowledge button does not clear the alarm. The voltage-free relay contact allows you to switch additional external signalling equipment such as the event reporting system EMS, horns and lamps in the case of alarm or error conditions. GM is suitable for control panel mounting with a mounting frame. A DIN rail clip is available for fast and easy mounting of GM to standard rails (DIN rail/EH50022). A sealing kit (IP 54) is available for rough application conditions.

GM 2.1 can be combined with suitable gas sensors:

- 1 gas sensor (methane or propane/butane)
- 2 gas sensors, also for different gases (methane and/or propane/butane)

Technical specifications

Inputs

2 sensors
Connection cable 3 wires
Wire cross section > 0.5 mm²

Distance control unit – sensor

Max. 150 m

Alarm threshold

1 permanently installed alarm threshold for alarm at approx. 20 % LEL with alarm memory

Indication

1 green LED: Operation
1 red LED: Flashing: error
Steady on: alarm

Audible alarm

Piezo buzzer approx. 70 dB(A), can be acknowledged

Switching outputs

Relay contacts: 1 voltage-free changeover contact
Contact rating: AC 250 V, 2 A

Supply voltage

AC 230 V

Power input

15 VA

Operating temperature range

Ambient: 0/40 °C

Housing

Wall mounting housing made of impact-resistant plastic (ABS)
W x H x D: 100 x 188 x 65 mm
Weight: 0.55 kg
Degree of protection: IP 30 (EN 60529)



Please order sensors separately.

DG: H	PG	Part no.	Price €
Gas detector GM 2.1	4	61150	

Gas sensors for GM 2.1, test gas bag for gas alarm unit/sensors



4

Gas sensor GS 4.1

Description Semiconductor gas sensor in plastic housing for connection to gas detector GM 2.1. To be used in dry rooms (e.g. heating facilities). Detectable gases: methane, propane, butane. LEDs at the sensor indicate the operating and alarm state of the gas alarm system:

- LED green: Operation
- LED yellow: Error
- LED red: Gas alarm

Technical specifications

Measured gas

Flammable gases and vapours in ambient air. Gas sensors are cross-sensitive to hydrocarbons, lacquers, solvents, alcohols and similar media.

Measuring range

0–50 % LEL

Measuring principle

Semiconductor (service life approx. 5 years, depending on the operating conditions)

Operating temperature range

Ambient: 0/50 °C

Humidity

Max. 75 % r.h.

Housing

Wall mounting plastic housing
W x H x D: 80 x 80 x 36 mm
Weight: Approx. 100 g

Test gas bag PGT 10 for gas alarm units/sensors

For checking and servicing gas alarm systems during function tests and system checks. Nylon bag case with test gas cap and withdrawal unit MiniFlo (valve, flow meter with stainless steel float for gas flow regulation from 0.5–1.5 l/min and test gas hose). Can accommodate 1 to 3 test gas cylinders.

Calibration gas not included in scope of delivery; please order separately.



Withdrawal unit MiniFlo

i

Gas sensor calibration

Prior to shipment, the gas sensors are calibrated and documented to the gas specified by the customer. Therefore, please always indicate the gas type when ordering.

	PG	DG			Part no.	Price €
Gas sensor GS 4.1 methane	4	H	1	-	61188	
Gas sensor GS 4.1 Propane/Butane	4	H	1	-	61189	
Test gas bag PGT 10 incl. withdrawal unit MiniFlo (without test gas cylinders)	4	H	1	-	500542	
Sampling unit MiniFlo , brass valve and Perspex flow meter with stainless steel float for gas flow control from 0.5 to 1.5 l/min, test gas hose	3	*	1	-	69050	
Calibration gas methane 20 % LEL , non-recyclable cylinder containing 12 l	2	*	1	-	69060	
Calibration gas methane 40 % LEL , non-recyclable cylinder containing 12 l	2	*	1	-	69061	
Calibration gas propane 20 % LEL , non-recyclable cylinder containing 12 l	2	*	1	-	69062	
Calibration gas propane 40 % LEL , non-recyclable cylinder containing 12 l	2	*	1	-	69063	
Calibration gas carbon monoxide (300 ppm) , non-recyclable cylinder containing 12 l	2	*	1	-	69064	
Synthetic air for zero point calibration , non-recyclable cylinder containing 12 l	2	*	1	-	69065	

* Net price. Enquire for other calibration gases and concentrations.

Probes for alarm units

Floor water probe BWS 10-1

Application For the detection of conductive liquids such as flood water, rainwater, tap water, fresh water, waste water, cooling water and heating water.

Description Floor probe suitable for WWG 1, ELT 8, ELT 680 and ELT 500/4. The probe is mounted at the lowest point of the object to be monitored. The alarm is triggered by the alarm unit when the probe comes into contact with liquid.

Probe diameter: 70 mm
Cable length: 2 m
Response level: approx. 2–3 mm



Floor water probe BWS 10-1

4

Wall mounting rail probe WSS

Application For the detection of conductive liquids such as rainwater, tap water, fresh water, waste water, cooling water and heating water.

Description Height-adjustable wall mounting rail probe suitable for WWG 2, ELT 8, ELT 680 and ELT 500/4. The probe is mounted to the wall at the object to be monitored. The desired response level (distance from probe to floor) is adjusted via the wall mounting rail. The alarm is triggered by the connected alarm unit when the probe comes into contact with liquid.

Dimensions: 37 x 320 x 55 mm
Cable length: 1.5 m
Height-adjustable: by approx. 200 mm



Wall mounting rail probe WSS

Floating probe SWS

Application For the detection of oil layers, emulsions or foam on water. Also suitable for changing levels (e. g. flowing bodies of water).

Description Floating probe suitable for ÖAWD-8, ELT 8 and ELT 680. The probe floats on the water surface. The oil layer thickness (at least 2 mm) is set via the height-adjustable 2-rod probe. The alarm is triggered by the connected alarm unit when the probe comes into contact with the oil layer.

Dimensions
W x H x D: 200 x 140 x 200 mm

Cable
Encapsulated cable connection
Length: 10 m

Adjustment range
2/10 mm oil layer thickness



Floating probe SWS



Many probe versions are available. Please enquire.

DG: H, PG: 4			Part no.	Price €
Floor water probe BWS 10-1	1	-	55112	
Wall mounting rail probe WSS	1	-	55050	
Floating probe SWS	1	-	55100	

Probes and accessories for alarm units

4

PTC thermistor probe

Application For the detection of liquids with a flash point of > 55 °C. Suitable for the following media: water, fuel oil, diesel fuel or low-viscosity lubricating oils, motor oils, hydraulic oils, vegetable oils and transformer oils, antifreeze agents, oil-water mixtures and emulsions.

Description Suitable for ÖWWG 3. The probe is mounted at the lowest point of the object to be monitored or in the drip pan. The alarm is triggered by the alarm unit when the probe comes into contact with liquid.

Probe diameter: 14 mm
Cable length: 3.2 m or 10 m
Response level: 17 mm



PTC thermistor probe

Photoelectric probe

Application For the detection of liquids with a flash point of > 55 °C. Suitable for the following media: water, fuel oil, diesel fuel or low-viscosity lubricating oils, motor oils, gearbox oils or hydraulic oils, vegetable oils and transformer oils.

Description Floor probe suitable for oil/water alarm unit OM 5. The probe is mounted at the lowest point of the object to be monitored. The alarm is triggered by the alarm unit when the probe comes into contact with liquid.

Probe diameter: 10 mm
Cable length: 10 m
Response level: 5 mm



Photoelectric probe

EnOcean® wireless module TCM 320

Application For remote indication and easy integration of WATCHDOG-LINE alarm units into smart home systems (such as AFRISO smart home) based on EnOcean® wireless. Users with mobile devices can immediately take appropriate action in response to an alarm.

Description EnOcean® wireless module for WATCHDOG-LINE alarm units. Can be plugged into PCBs of boards which are factory-equipped with a slot for the EnOcean® wireless module. Can be integrated into all AFRISO products with the label "EnOcean-ready" on the front.



EnOcean® wireless module TCM 320

DG: G, PG: 4			Part no.	Price €
Spare probe ÖWWG 3, length 3.2 m, year of manufacture 09/2013 and later	1	-	44516	
Spare probe ÖWWG 3, length 10 m, year of manufacture 09/2013 and later	1	-	44484	
Spare probe ÖWWG 3, length 25 m, year of manufacture 09/2013 and later	1	-	44482	
Spare probe ÖWWG 3, length 3.2 m, year of manufacture up to 8/2013	1	-	44481	
Photoelectric probe	1	-	44503	
EnOcean® wireless module TCM 320	1	-	78082	

Accessories for alarm units

Drip pan

Application For the collection of, e. g., escaping oil. Drip pans should be mounted below all oil fittings such as filters, oil vents, burners, etc. in order to avoid damages resulting from escaping oil and in order to detect leaks as early as possible.

Description Drip pan made of white plastic (PE). At the lowest part of the drip pan, the sensor of an oil alarm unit can be installed, e. g. the oil alarm unit ÖWWG 3. If the drip pan cannot be checked on a daily basis, oil alarms with audible and visual alarms are required. Several independent drip pans can be monitored, e. g. with a single oil alarm unit OM 5 and up to 5 probes. A mounting clamp for the sensor is supplied with the drip pan.

Dimensions (W x D): 600 x 300 mm



Drip pan

4

Mounting frame

Description Mounting frame for wall mounting housings 100 x 188 x 65 mm (W x H x D) of the WATCHDOG-LINE alarm units from year of manufacture 10/2007. For fast integration in control cabinets.



Mounting frame

Sealing kit (IP 54)

Description Sealing kit for rough application conditions. Suitable for all wall mounting housings of the WATCHDOG-LINE alarm units from year of manufacture 10/2007, with the exception of tank contents indicators DTA 10/20 and backup controller RENA. The sealing kit is easy to mount between the housing cover and base. This increases the degree of protection of the alarm unit to IP 54.





Sealing kit (IP 54)

DIN rail clip

Description DIN rail clip for fast and easy mounting of WATCHDOG-LINE alarm units in the control cabinet or for side-by-side mounting of several units on the wall. The clip is mounted by means of screws so that the alarm unit can be clipped onto standard DIN rails.



DIN rail clip

DG: G, PG: 1			Part no.	Price €
Drip pan	1	-	44512	
Mounting frame	1	-	43521	
Sealing kit (IP 54)	1	-	43416	
DIN rail clip	1	-	43100	

Signalling devices

4



Combined warning light and horn WLH 1

- Benefits**
- Highly effective signal due to yellow light
 - Loud 90 dB alarm tone
 - Warning light and horn can be controlled separately

Application For dry indoor spaces.

- Technical specifications**
- Sound pressure** 90 dB (A), distance 1 m
 - Supply voltage** AC 230 V
 - Power input** 10 VA
 - Degree of protection** IP 33 (EN 60529)
 - Weight** 0.19 kg

Horn KH 1

- Loud 90 dB alarm tone
- Horn with continuous tone

For dry indoor spaces.

- Sound pressure** 90 dB (A), distance 1 m
- Supply voltage** AC 230 V
- Power input** 6 VA
- Degree of protection** IP 20 (EN 60529)
- Weight** 0.18 kg

DG: G, PG: 4			Part no.	Price €
Combined warning light and horn WLH 1	1	-	61020	
Horn KH 1	1	-	61011	

Signalling devices



Horn HPW 2

- Benefits**
- Loud 110 dB alarm tone
 - Horn with continuous tone

Application For humid rooms and for outdoor installation.

Technical specifications **Sound pressure**
110 dB (A), distance 1 m

Supply voltage
AC 230 V

Power input
22 VA

Degree of protection
IP 55 (EN 60529)

Weight
1 kg



Warning light with rotating reflector SLD 1

- Highly effective signal due to yellow light and rotating reflector
- Robust design with Al base
- Maintenance-free

For humid rooms and for outdoor installation.



Supply voltage
AC 230 V

Degree of protection
IP 55 (EN 60529)

Weight
1.8 kg

Mounting position
Any

4

DG: G, PG: 4	PG	DG			Part no.	Price €
Horn HPW 2	4	G	1	-	61012	
Warning light with rotating reflector SLD 1	4	H	1	-	61015	

Additional alarm unit ZAG 01



4

- Audible and visual alarms for maximum safety
- Manufacturer-independent use with devices with switching output (relay contact)
- With 2 voltage-free changeover contacts (at output side)
- Ready-to-connect device for easy installation and commissioning

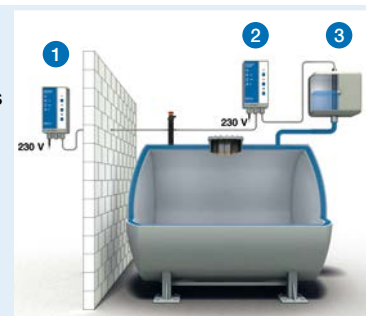

- 1 Additional alarm unit ZAG 01
- 2 Leak detector LAG 13
- 3 LAG container with probe

Application For indication and transfer of alarm signals from WATCHDOG-LINE alarm units, AFRISO leak detectors or any other switching equipment. Suitable for triggering additional visual and audible alarms in buildings, e.g. in the case of underground tank facilities or in rooms which are far away from the dangerous location. Can be connected directly to the switching output of the alarm unit.

Description The additional alarm unit in a wall mounting housing signals alarm conditions in conjunction with an alarm unit or a leak detector. ZAG 01 is connected to the voltage-free contact of the alarm unit. A 230 V alarm input is also available. The audible alarm can be acknowledged with the Acknowledge button in the case of an alarm. The visual alarm is cleared once the leak or event has been removed. The Test button allows you to perform a function test.

The voltage-free relay contacts allow for connection of additional external signalling equipment (such as horns), event reporting systems EMS, building control systems or similar equipment. ZAG 01 is suitable for panel mounting with a mounting frame. A sealing kit (IP 54) is available for rough application conditions.

Technical specifications

Operating temperature range

Ambient/storage: -10/+60 °C

Supply voltage

AC 230 V

Nominal power

3 VA

Alarm input

Input 1: Voltage-free
Input 2: AC 230 V

Switching outputs

Relay contact 1:
voltage-free changeover contact,
can be acknowledged

Relay contact 2:
voltage-free changeover contact,
cannot be acknowledged
Contact rating: AC 250 V, 2 A

Alarm sound

Min. 70 dB (A)

Housing

Wall mounting housing made of
impact-resistant plastic (ABS)
W x H x D: 100 x 188 x 65 mm

Degree of protection

IP 30 (EN 60529)

DG: H, PG: 4	Part no.	Price €
Additional alarm unit ZAG 01	40633	

CATALOGUE INDUSTRIAL TECHNOLOGY

Industrial alarm units



Gas alarm unit/station GW-S/GW-SK

- + Versions with compact DIN rail housing or wall mounting housing
- + For connection of up to six sensors/measuring points
- + Options: Serial interface, emergency power module, data logger

Sensor inputs
4–20 mA, RS-232 interface for configuration

Switching outputs
4/6 voltage-free relay contacts



Page 341



Probes for GW-S/GW-SK

- + Versions for the detection of flammable or combustible gases or for monitoring oxygen concentrations and toxic gases
- + For monitoring of combustible gases and vapours or carbon monoxide



Page 343



This and many other products can be found in the catalogue INDUSTRIAL TECHNOLOGY.

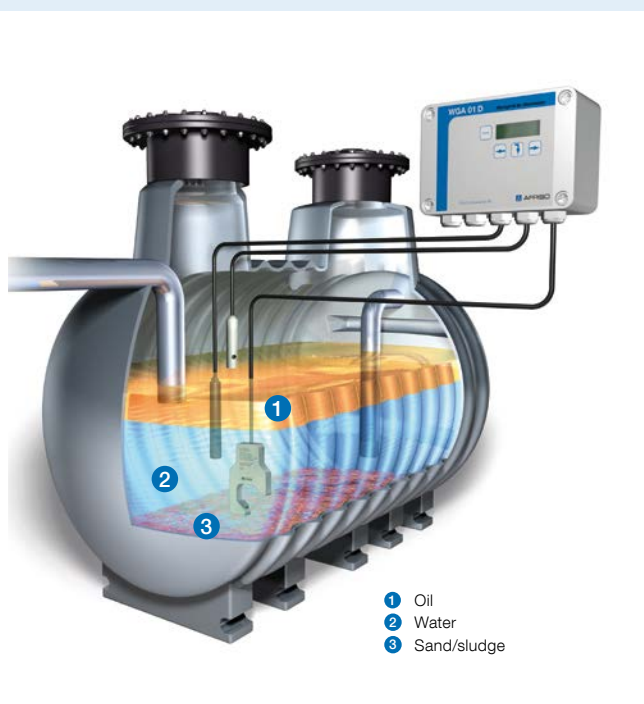

- 1 Oil
- 2 Water
- 3 Sand/sludge



Alarm units for separators

- + For oil, petrol and grease separator systems
- + Probes for all applications: Layer thickness alarm, overflow alarm, sludge alarm, sand alarm or oil-on-water alarm
- + With visual/audible alarms and relay output
- + Version WGA 01 D with LC display for plain text messages



Page 336



reddot award 2014
winner

Temperature control



Water sensors

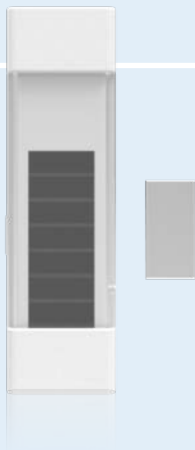

Wireless automation



AFRISOhome gateway

CHAPTER 5

AFRISO smart home: Intelligent alarm units, sensors and actuators for building automation

OVERVIEW

Building automation with AFRISO smart home	92
Sensors for the detection of water leakage	94
WATCHDOG-LINE alarm units with EnOcean® wireless	120

ALARM UNITS

Mechanical water sensor WaterSensor eco	95
Conductivity water sensor WaterSensor con	96
Conductivity water sensor WaterSensor BWS	97
Radio-controlled water valve WaterControl	98
Temperature and pressure measuring instrument TDM 51 F	99
Digital tank contents indicator DTA 20 E	100
Wireless smoke alarm ASD	101
Wireless heat detector AHD 10	102

HOME COMFORT

Single room temperature controller CosiTherm® wireless	103
Room temperature sensor FT/FTF	106
Wireless transmitter for temperature and/or humidity FTM T/TF	107
Temperature and humidity sensor FTM 20 TF	108
Wireless actuator AVD 30 for radiators	109
CO₂ sensor	110

WIRELESS AUTOMATION

Universal wireless transmitter FTM	111
Wireless rocker switch FT4F-rw	112
Door and window contact AMC 20	113
Indoor siren AIS 10/PRO with repeater function	114
Spare parts and accessories for AFRISO Smart Home	119

CENTRAL CONTROL/MANAGEMENT

AFRISOhome gateway HG 02	116
Mobile app AFRISOhome	118

Customised building automation with AFRISO smart home

5

The diagram illustrates the AFRISO smart home ecosystem. A central blue square with a white triangle points to four main categories: **INDOOR CLIMATE** (represented by a radiator, a fan, and a thermometer), **COMFORT** (represented by a lightbulb, a document, and a house with a heart), **SECURITY** (represented by a house with a camera, a door, a window, a fire, and a water drop), and **INDUSTRY SOLUTIONS** (represented by a house, a factory, and a wrench). Below the diagram are two download buttons: "Download on the App Store" and "GET IT ON Google Play". To the right, a smartphone displays the AFRISO app interface. The app shows a personalized greeting "Hey Max" and a notification "are you hungry too?". The main screen features four control cards: "Lights" (All on), "Climate" (20.6 - 25.5 °C, 48 - 50 %, 384 - 566 ppm), "Door/Window" (All closed), and "Security" (Motion detector reports Motion alarm!). The bottom navigation bar includes "My Home", "Devices", "PROGRAMS", and "Groups".

Safety means more comfort – the intelligent, energy-saving building with AFRISO smart home

AFRISO has been manufacturing alarm units for the safe operation of tank facilities and heating systems for more than 60 years. So far, alarms were mainly signalled directly on site. Transferring alarm messages to building control systems was possible, but it involved considerable effort. The wireless transmission standard EnOcean®, available for domestic technology since 2003, breaks new ground for a completely different approach to building automation. The transmission protocol allows a whole range of different products to be networked on the basis of EnOcean® wireless. This technological milestone breaks new ground for building automation not only in new buildings – reasonably priced intelligent networking becomes possible in existing buildings. Products with an EnOcean® wireless module do not require cable connections to a building control centre and can be used almost anywhere in buildings due to their compact design.

Manufacturers from a great variety of areas have teamed up in the EnOcean® Alliance and offer a large range of products. With the smart home system, AFRISO has developed a portfolio of outstanding sensors and alarm units for reliable leakage protection (for example, water/oil) as well as devices for controlling heating systems in an economical way. AFRISO smart home products are cost-effective, reliable and practical.

Even for end customers, there are no more barriers to entry into the networked world of customised, modularly extensible building automation and security systems. The perfect approach to a flexible smart home solution.



No cables.

No cables are required for building automation systems on the basis of the EnOcean® wireless technology. Ten metres of power cable (NYY 3 x 1.5 mm) weigh approx. 2.3 kg – not using this cable saves money and is great for the environment.



No batteries.

Energy harvesting is the foundation of battery-less, maintenance-free and flexible building automation. The energy required for sending messages is derived from ambient sources – small movements, pressure, light, temperature or vibration are sufficient to allow for power-independent operation of the sensors.



No limits.

Renovation projects and new buildings benefit from the new, creative and innovative developments based on EnOcean® wireless technology. There are countless ways of combining EnOcean® products.





A fully featured smart home system on the basis of EnOcean wireless technology networks all light, heating and air conditioning control systems via a central gateway. The gateway processes sensor and consumption data, triggers control action and initiates other measures, and transmits the information to mobile devices such as smartphones, tablets, etc. via WLAN or Internet. Products from other members of the EnOcean® Alliance for controlling household appliances can also be integrated.



AFRISO Smart Home

- | | |
|-----------------------------------------------------------------------|--------------------------------------------------------------------|
| 1 Radio-controlled water valve WaterControl | 8 Indoor siren AIS 10 |
| 2 Wireless conductivity water sensor WaterSensor BWS | 9 AFRISOhome gateway |
| 3 Digital tank contents indicator DTA 20 E | 10 Heat detector AHD 10 |
| 4 Room air monitoring: CO₂ sensor wireless | 11 Wireless mechanical water alarm WaterSensor eco |
| 5 Single room temperature controller CosiTherm®-Funk | 12 Wireless smoke detector ASD 10 |
| 6 Wireless room temperature sensor FT | 13 Wireless actuator for radiators AVD 30 |
| 7 Wireless rocker switch FT4F-rw | |

Sensors for the detection of water leakage

				
Product type	WaterSensor eco	WaterSensor con	WaterSensor BWS 10-2	WWG 1 with BWS 10-1
Catalogue page	See page 95	See page 96	See page 97	See page 77
Typical applications	Inaccessible areas without light source or areas where battery replacement is difficult or impossible, e.g. below bathtubs, sinks, kitchen cabinets, refrigerators, shafts, etc.	Accessible areas subject to sunlight or areas where batteries can be replaced, in living spaces.	Accessible areas subject to sunlight or areas where batteries can be replaced, in basements or utility rooms.	Most robust and reliable version for industrial facilities, basements, storage rooms, etc.
Measuring principle	Fibre disks	Conductivity	Conductivity	Conductivity
EnOcean® wireless	•	•	•	Via additional module TCM 320
AFRISO HG 01/ HG 02	•	•	•	•
homee EnOcean® Cube	•	•	•	
wiButler	•	•	•	
alphaEos	•	•	•	
Digital Concepts	•	•	•	•
Eltako GFVS	•			
Standalone operation with AFRISO water valve WaterControl 01.1	•	•	•	•
Availability monitoring (heartbeat)		•	•	•
External power supply	Energy Harvesting	Energy harvesting via solar cell or optional battery	Energy harvesting via solar cell or optional battery	AC 230 V (mains voltage monitoring and alarm in the case of power outage)
Response level	1.5 mm	0.5 mm	2–3 mm	2–3 mm
Response delay	< 6 minutes	None	None	None
Non-breakable probe			•	•
Floor mounting	•		•	•
Wall mounting			•	•
Integrated temperature measurement		•	•	

5

Can be connected to the following gateways

Mechanical water sensor

WaterSensor eco



- Flexible location-independent use anywhere in buildings
- No battery, no cables required
- Wireless transmission without power supply in the case of state transitions



Battery-less sensor system: Fibre disks generate the energy to signal events

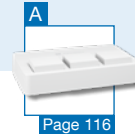

Application For the detection of accumulations of water at defined horizontal surfaces or positions (e.g. below pipes, fittings and in the area of washing machines, below bath tubs or dishwashers, in utility rooms or basements). Suitable for water.

Description WaterSensor eco is equipped with fibre disks that work as a sensor; it does not require an additional power supply. In the case of a leak, the fibre disks expand and generate the required power to send the event message to WaterControl or to the AFRISOhome gateway. The event message is sent when the fibre disks expand or shrink. WaterControl can be used, for example, to shut off the water pipe to keep further water from escaping. The AFRISOhome gateway transmits alarm messages and state transition messages via WLAN or LAN to the person in charge (for example, to the owner, the facility manager, the janitor or other configured contacts); the message includes information on which WaterSensor eco has signalled the state transition. The AFRISOhome gateway in conjunction with additional AFRISO smart home products with EnOcean® wireless technology allows the user to configure a whole range of fully customisable, extensible applications.

Technical specifications

Operating temperature range

Ambient: -25/+65 °C
Storage: -25/+65 °C
Medium: 1/65 °C

Response level

1.5 mm

Response delay

< 6 min (for the first 5 expansion processes)
up to 1 hour (for expansion processes 6 to 10.)

Supply voltage

Energy harvesting (via fibre disks)

Housing

Plastic housing (PC)
Colour: White, similar to RAL 9003
W x H x D: 80 x 55 x 30 mm
Weight: 66 g
Degree of protection: IP 43 (EN 60529)

EnOcean® wireless

EEP: F6-05-01
Frequency: 868.3 MHz
Transmission power: Max. 10 mW
Range: 10 to 30 m (depending on room arrangement and materials in the building)

Scope of delivery

- WaterSensor eco
- Adhesive tape

Necessary additional components

- WaterControl and/or
- AFRISOhome gateway

i

See operating instructions for detailed information on the range of the EnOcean® wireless module.

DG: L, PG: 4	Part no.	Price €
Water sensor WaterSensor eco	55080	

Conductivity water sensor

WaterSensor con



- No cables required (operation via photovoltaic cell or battery)
- Shapely probe for use in living spaces, kitchens or business rooms
- Additional temperature measurement

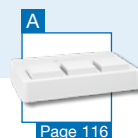

5

Application For the detection of accumulations of water at defined horizontal surfaces or positions (e.g. in the area of fittings washing machines, coffee makers with water connection, etc.). Suitable for water.

Description WaterSensor con features a conductivity sensor at the bottom. The energy required to send an EnOcean® telegram is generated by means of an integrated photovoltaic cell. An optional battery can be used for application in darker rooms. An extension cable is available for separate mounting of sensor and wireless transmitter. WaterSensor con cyclically transmits the actual ambient temperature and the logical state of the conductivity sensor (conductive liquid present or not present) and also sends a telegram when the state changes via the integrated EnOcean® wireless module to the water valve WaterControl or to the AFRISOhome gateway.

WaterControl can close the water pipe in response to an event message to keep further water from escaping. The AFRISOhome gateway transmits alarm messages and status messages via WLAN or LAN to the person in charge (for example, to the owner, the facility manager, the janitor or other configured contacts); the message includes information on which water sensor has signalled the state transition.

The AFRISOhome gateway in conjunction with additional AFRISO smart home products with EnOcean® wireless technology allows the user to configure a whole range of fully customisable, extensible applications.

Technical specifications

Operating temperature range

Ambient: 0/40 °C
Storage: -20/+60 °C
Medium: 1/60 °C

Response level

0.5 mm

Temperature measuring range

Measuring range: 0/40 °C
Accuracy: ±1 K

Supply voltage

Energy harvesting (via photovoltaic cell) or 1/2 AA lithium battery, DC 3.6 V (with daylight less than 200 lx)

Housing

Plastic housing (PC)
Colour: White, similar to RAL 9003
W x H x D: 55 x 50 x 42 mm
Weight: 47 g
Degree of protection: P 42 (EN 60529)

EnOcean® wireless

EEP: A5-30-03
Frequency: 868.3 MHz
Transmission power: Max. 10 mW
Range: 10 to 30 m (depending on room arrangement and materials in the building)

Scope of delivery

- WaterSensor con
- Without battery

Necessary additional components

- WaterControl and/or
- AFRISOhome gateway



See operating instructions for detailed information on the range of the EnOcean® wireless module.

DG: L, PG: 4	Part no.	Price €
Water sensor WaterSensor con	78146	

Conductivity water sensor

WaterSensor BWS



- No cables required (operation via photovoltaic cell or battery)
- Robust, non-breakable probe especially for utility rooms
- Additional room temperature measurement via wireless transmitter

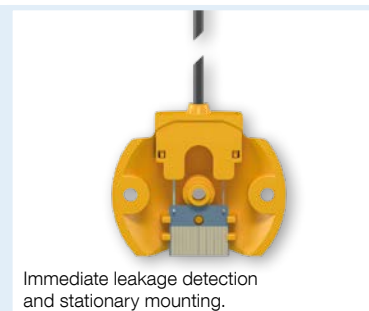
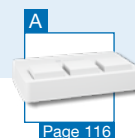

5

Application For the detection of accumulations of water at defined horizontal surfaces or positions (e.g. in the area of fittings, washing machines, below pipes, etc.). Suitable for water.

Description WaterSensor BWS consists of a probe with extension cable and a wireless transmitter with an integrated temperature sensor. The probe features a conductivity sensor at the bottom. The energy required to send an EnOcean® telegram is generated by means of a photovoltaic cell in the wireless transmitter. An optional battery can be used for application in darker rooms. WaterSensor BWS cyclically transmits the actual ambient temperature and the logical state of the conductivity sensor (conductive liquid present or not present) and also sends a telegram when the state changes via the integrated EnOcean® wireless module to the water valve WaterControl or to the AFRISOhome gateway. WaterControl can close the water pipe in response to an event message to keep further water from escaping. The AFRISOhome gateway transmits alarm messages and status messages via WLAN or LAN to the person in charge (for example, to the owner, the facility manager, the janitor or other configured contacts); the message includes information on which water sensor has signalled the state transition. The AFRISOhome gateway in conjunction with additional AFRISO smart home products with EnOcean® wireless technology allows the user to configure a whole range of fully customisable, extensible applications.

Technical specifications

Operating temperature range

Ambient: 0/40 °C
Storage: -20/+60 °C
Medium: 1/60 °C

Response level

Approx. 2–3 mm

Temperature measuring range

Measuring range: 0/40 °C
Accuracy: ±1 K

Supply voltage

Energy harvesting (via photovoltaic cell) or 1/2 AA lithium battery, DC 3.6 V (with daylight less than 200 lx)

Housing

Plastic housing (PC)
Colour: White, similar to RAL 9003
W x H x D: 55 x 50 x 42 mm
Weight: 47 g
Degree of protection: IP 42 (EN 60529)

Housing floor probe BWS 10.2

EEP: A5-30-03
Dimensions Ø x L: 75 x 40 mm
Cable length: 1.80 m

EnOcean® wireless

Frequency: 868.3 MHz
Transmission power: Max. 10 mW
Range: 10 to 30 m (depending on room arrangement and materials in the building)

Scope of delivery

- Wireless transmitter
- Sensor BWS 10-2 with connection cable
- Without battery

Necessary additional components

- WaterControl and/or
- AFRISOhome gateway



See operating instructions for detailed information on the range of the EnOcean® wireless module.

DG: L, PG: 4	Part no.	Price €
Water sensor WaterSensor BWS	55120	
Spare probe BWS 10-2	55116	

Water valve WaterControl 01.1 with wireless control



- Immediate shutting off of the water pipe in the case of a leak
- Reduced damage after pipe burst
- Shut-off valve with modular design, removable motor and ball valve with additional screw connection for easy mounting, also if mounting space is limited



Page 95



Page 96



Page 118

Application For manually or remotely controlled closing and opening of a water pipe in buildings in response to an event message from the water sensors WaterSensor eco, con or BWS.

Description WaterControl 01.1 consists of a shut-off valve and a control unit with power supply and an EnOcean® wireless module. The shut-off valve features a drinking water-approved ball valve with an electric motor which is integrated in the water-carrying pipe. Two ball valves (G1 male / G1½ male) with corresponding screw connections for G¾ female and G1 female / G1¼ female and G1½ female are available.

There several ways to open and close the shut-off valve in the water pipe:

- Opening/closing the shut-off valve mechanically via the operating handle
- Opening/closing the shut-off valve electrically via buttons at the control unit
- Closing the shut-off valve via water sensors
- Opening/closing the shut-off valve via EnOcean® switch
- Opening/closing the shut-off valve via AFRISOhome gateway and smartphone

The control unit has a permanent wireless connection to the water sensors WaterSensor eco or WaterSensor con or WaterSensor BWS and/or the AFRISOhome gateway. An event message is triggered if the water sensors detect a leak, e.g. caused by a defective household appliance or a water pipe burst. WaterControl 01.1 can be used, for example, to shut off the water pipe to keep further water from escaping. The AFRISOhome gateway transmits alarm messages and state transition messages via WLAN to the person in charge (for example, to the owner, the facility manager, the janitor or other configured contacts).

Technical specifications

Operating temperature range

Ambient: 0/50 °C
Storage: -10/+80 °C
Medium: 4/80 °C

Supply voltage

AC 100–240 V

Nominal power

Motor at standstill: < 2 VA
Motor running: < 5 VA

Housing

Wall mounting housing made of impact-resistant plastic (ABS)
W x H x D: 100 x 188 x 65 mm
Weight: 430 g
Degree of protection: IP 40 (EN 60529)

Ball valve (DVGW-tested) with motor

Weight: 800 g to 2 kg
Degree of protection: IP 40 (EN 60529)

EnOcean® wireless

EEP: D2-A0-01
Frequency: 868.3 MHz
Transmission power: Max. 10 mW
Range: 10 to 30 m (depending on room arrangement and materials in the building)

Devices to teach in

Teach in of up to 40 devices:

- 1 EnOcean® centre/gateway
- WaterSensor con (20 x)
- WaterSensor eco (10 x)
- WaterSensor BWS
- EnOcean® rocker switch open/close (10 x)
- Water alarm unit WWG in any combination



See operating instructions for detailed information on the range of the EnOcean® wireless module.

DG: G, PG: 4	Part no.	Price €
WaterControl 01.1 G¾	42570	
WaterControl 01.1 G1	42571	
WaterControl 01.1 G1¼	42575	
WaterControl 01.1 G1½	42576	

Temperature and pressure measuring instrument TDM 51 F



- Ideal for measuring a great variety of values and parameters in domestic technology applications
- Pressure and temperature sensors can be connected
- Integrated mains voltage monitoring
- EnOcean®-inside



Page 118

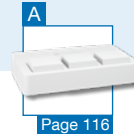

Page 116

5

Application For measuring pressure and temperature in domestic technology applications such as filling pressure in the heating system, level in fuel oil tanks or cisterns, layer temperature in hot water storage tanks or system temperatures (e.g. flow, return).

Description The temperature and pressure measuring instrument TDM 51 F features five inputs for Pt 1000 temperature sensors and an RS 485 Modbus connection for digital temperature sensors. The measured data is transmitted to the AFRISOhome gateway HG 01 via an integrated EnOcean® wireless module. The measured data is visualised on the AFRISOhome application. If the measured value is out of range, groups of persons (e.g. owner or janitor) can be notified selectively. TDM 51 F monitors the mains voltage and sends an alarm message in the case of a power outage. EnOcean® wireless technology allows for integration into building control systems.

Technical specifications

Operating temperature range

Ambient: -5/+55 °C

Supply voltage

AC 100–240 V

Nominal power

2.5 VA

Housing

Wall mounting housing made of impact-resistant plastic (ABS)

W x H x D: 100 x 188 x 65 mm

Weight: 430 g

Degree of protection: IP 40 (EN 60529)

Inputs

- 5 x Pt 1000 (2-wire), measuring range: -100/+300 °C
- 1 x Modbus RTU (RS 485)

Accuracy

Temperature: ±0.5 K

Pressure: Depends on sensor used

EnOcean® wireless

EEP: Generic Profile (GP)

Frequency: 868.3 MHz

Transmission power: Max. 10 mW

Range: 10 to 30 m (depending on room arrangement and materials in the building)

Scope of delivery

- Control unit with EnOcean® wireless module

i

See operating instructions for detailed information on the range of the EnOcean® wireless module.

See catalogue INDUSTRIAL TECHNOLOGY., chapters 3 / 4, for temperature and pressure sensors.

DG: G, PG: 4	Part no.	Price €
Temperature and pressure measuring instrument TDM 51 F	78089	

Digital tank contents indicator DTA 20 E



- Plug & play level indicator for smart home systems based on EnOcean® wireless
- Daily measurement and worldwide access to consumption data
- Local display and push message (adjustable) when minimum level is reached
- For fuel oil, (bio) diesel, water and other media with a density between 0.5 and 1.5 g/cm³

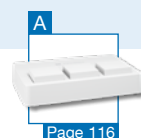

5

Application

Location-independent level measurement with digital display and minimum level signal (reserve level alarm). If the product is operated in conjunction with the AFRISOhome gateway, the tank operator/owner can read the level on a mobile device in addition to the local display. Suitable for tanks up to 400 cm liquid level. For fuel oil EL, L or diesel fuel, FAME 100 % as biodiesel (EN 14214) and water (no drinking water!) and for AdBlue®. In addition, DTA 20 E can be used for level measurement with all non-corrosive liquids with a density from 0.5 to 1.5 g/cm³. Remote measurements (measuring line) up to 15 m.

Description

The electro-pneumatic tank contents indicator DTA 20 E consists of a control unit with power supply unit, an EnOcean® wireless module, a digital display and a measuring line. Measured values are displayed in litres, % and liquid level (cm). Simple operation and setup via three function keys at the device. DTA 20 E measures the level (adjustable interval) and transmits it to the AFRISOhome gateway via EnOcean® wireless. In addition, measurements can be taken by means of pressing the control key (Push-to-Read function). If the level falls below a minimum level that is freely adjustable as a percentage, the backlight of the display flashes red to indicate an alarm during the measurement. In addition to indication on the local display, the tank owner/operator can receive a push message on the smartphone or tablet. Standard tank shapes (linear and cylindrical, horizontal) are stored.

Technical specifications

Functions

Periodic level measurement (1 to 240 hours) with wireless transmission to master systems such as AFRISOhome gateway
Push-to-Read level measurement

Measuring range (tank height)

0/400 cm (fuel oil)
0/350 cm (water)

Measuring accuracy

±3.0 cm

Operating temperature range

Ambient: 0/50 °C
Storage: -20/+65 °C
Medium: 0/50 °C

Display

Multi-coloured, backlit graphical display (30 x 50 mm):

- White = Operation
- Red = Alarm
- Green = Setup

Indication of litres (5 digits), % or liquid level in cm

Measuring line

PVC hose 4 x 1 mm
Length 20 m
Balance chamber stainless steel

Supply voltage

AC 100–240 V

Minimum alarm

Backlight flashes red
Push message to mobile devices

Housing

Wall mounting housing made of impact-resistant plastic (ABS)
W x H x D: 100 x 188 x 65 mm
Degree of protection: IP 20 (EN 60529)

EnOcean® wireless

EEP: Generic Profile (GP)
Frequency: 868.3 MHz
Transmission power: Max. 10 mW
Range: 10 to 30 m (depending on room arrangement and materials in the building)

Scope of delivery

- Control unit with power supply unit
- Pneumofix type 2:
20 m measuring line with bottom part, connection kit for G½, G1, G1½ and G2, 30 x nail cable clips, hose connectors (4 x 4 mm), mounting accessories

Necessary additional components

AFRISOhome gateway

DG: L, PG: 4	Part no.	Price €
DTA 20 E with Pneumofix 2	52146	
DTA 20 E without Pneumofix 2	52156	
Power supply unit 9 V with mains plug for DTA series	52148	



See operating instructions for detailed information on the range of the EnOcean® wireless module.

Wireless smoke alarm ASD



- Immediate triggering of an alarm before a flue gas concentration becomes hazardous
- Wireless transmission, cyclically (function check) and in the case of state transitions
- Compact, unobtrusive design
- Design as per EN 14604

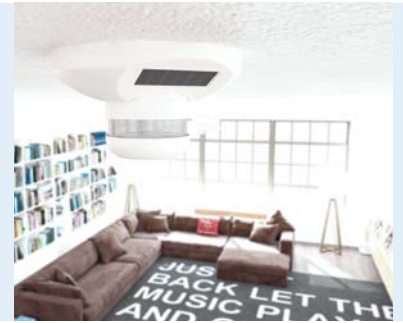

Page 118

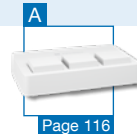

Page 116

5

Application For detection of fumes and smoke gas in living spaces. Audible alarm when a defined smoke concentration is exceeded.

Description The photoelectric smoke alarm ASD consists of a sensor head and a mounting base with integrated EnOcean® wireless module. The sensor head features a permanently installed lithium battery with a service life of up to 10 years for reliable, long-term fire protection. A fire alarm is indicated by an alarm tone with approx. 85 dB and a flashing LED. The alarms are transmitted via the EnOcean® wireless module. In addition, ASD 10 transmits the ambient temperature. A photovoltaic cell generates the required energy. A battery can be inserted in the base for use in darker environments.

Wireless smoke alarm ASD 10 with transmission of fire alarm and current room temperature.

Wireless smoke alarm ASD 20 with transmission of fire alarm and battery state of the mounting base for the EnOcean® wireless module.

The AFRISOhome gateway lets you program a great variety of scenarios for an alarm, for example switching on the lights for the escape route, opening of shutters for escaping, push messages, etc. The EnOcean® wireless module is not only used for transmission, but also for regular function checks.

Technical specifications

Operating temperature range

Ambient: 0/+40 °C
Storage: -20/+60 °C
Max. humidity, non-condensing

Supply voltage

Sensor head: Permanently installed lithium battery
Base: Energy harvesting (via photovoltaic cell) or 1/2 AA lithium battery, DC 3.6 V (with daylight less than 200 lx)

Housing

Plastic housing (PC)
Colour: White, similar to RAL 9003
ø x H: 87 x 48 mm
Weight: 38 g
Degree of protection: P 54 (EN 60529)

EnOcean® wireless

EEP: A5-30-03 (ASD10) / F6-05-02 (ASD20)
Frequency: 868.3 MHz
Transmission power: Max. 10 mW
Range: 10 to 30 m (depending on room arrangement and materials in the building)

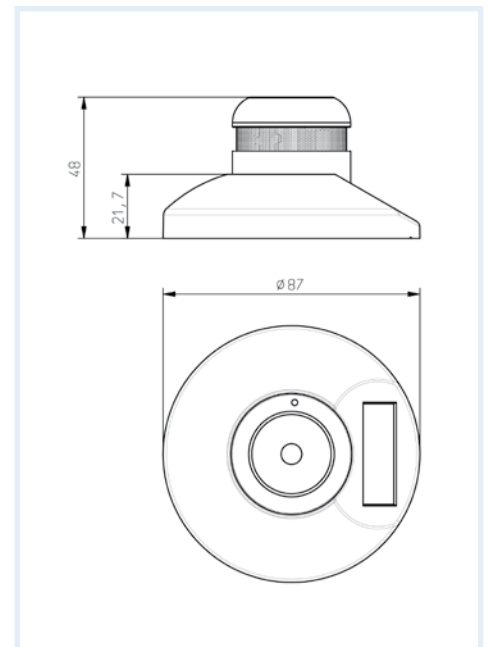

See operating instructions for detailed information on the range of the EnOcean® wireless module.

DG: L, PG: 4	Part no.	Price €
Wireless smoke alarm ASD 10	61245	
Wireless smoke alarm ASD 20	61249	
Spare part		
Sensor head smoke alarm ASD 10 SH	61246	

Wireless heat detector

AHD



- Immediate triggering of an alarm if the temperature rises rapidly and if it exceeds 58 °C
- Wireless transmission, cyclically (function check) and in the case of state transitions
- Compact, unobtrusive design
- Design as per EN 54-5 class A1/R

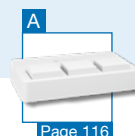

5

Application For detection of heat and fire in living spaces. Audible alarm and direct transmission to the AFRISOhome gateway if the temperature rises rapidly or if it exceeds 58 °C. AHD is ideal for use in rooms subject to generation of smoke or vapour (such as kitchens, bathrooms) or in which dust, dirt and exhaust gases can develop (such as workshops, garages). Recommended if smoke alarms cannot be used due to possible false alarms.

Description The heat detector AHD consists of a sensor head and a mounting base with integrated EnOcean® wireless module. The sensor head features a permanently installed lithium battery with a service life of up to 10 years for reliable, long-term fire protection. A fire alarm is indicated by a flashing LED and a sound sequence with the maximum alarm sound pressure of 85 dB. The alarm is also transmitted via the EnOcean® wireless module. A photovoltaic cell generates the required energy. A battery can be inserted in the base for use in darker environments. Each heat detector has a unique ID so that the recipient can distinguish the individual heat alarms if multiple sensors are used. The AFRISOhome gateway lets you program a great variety of scenarios for an alarm, for example switching on the lights for the escape route, opening of shutters for escaping, push messages, etc. The EnOcean® wireless module is not only used for transmission, but also for regular function checks.

AHD 10 with transmission of fire alarm and current room temperature.

AHD 20 with transmission of heat alarm and battery status of mounting base.

Technical specifications

Operating temperature range

Ambient: -10/+50 °C

Storage: -20/+60 °C

Max. humidity: 90 %, non-condensing

Supply voltage

Sensor head: Permanently installed lithium battery

Base: Energy harvesting
(via photovoltaic cell)
o 1/2 AA lithium battery,
DC 3.6 V (with daylight
less than 200 lx)

Housing

Plastic housing (PC/ABS)

Colour: White, similar to RAL 9003

ø x H: 86 x 45 mm

Weight: 38 g

Degree of protection: IP 30 (EN 60529)

EnOcean® wireless

EEP: A5-30-03 (AHD 10),

F6-05-02 (AHD 20)

Frequency: 868.3 MHz

Transmission power: Max. 10 mW

Range: 10 to 30 m
(depending on room arrangement
and materials in the building)

Approval

EN 54-5, class A1/R for heat detection systems

Scope of delivery

- Wireless mounting base
- Heat detector
- Mounting accessories



See operating instructions for detailed information on the range of the EnOcean® wireless module.

DG: L, PG: 4	Part no.	Price €
Wireless heat detector AHD 10	61550	
Wireless heat detector AHD 20	61553	
Spare part		
Sensor head heat detector AHD 10 SH	61551	

Single room temperature controller CosiTherm® Wireless

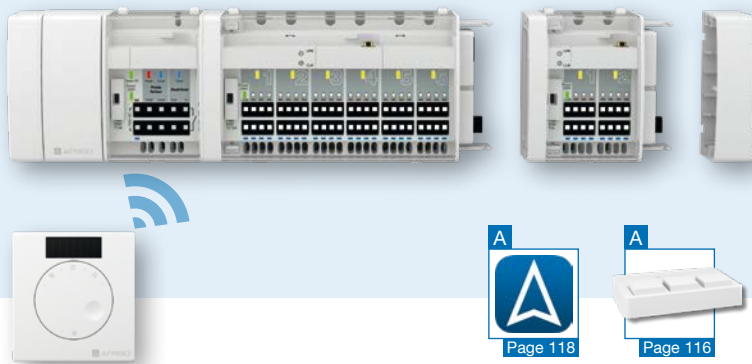

- Controller terminal bar for connection of actuators
- For manifold systems for heating and cooling
- Worldwide access via AFRISOhome gateway



Page 118

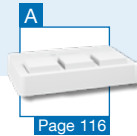

Page 116



Page 106



Page 220

5

Application Controls the temperature of individual rooms in connection with manifold systems for heating or cooling. EnOcean® wireless technology for integration into building automation systems.

Description The base version of the single room temperature controller CosiTherm® Wireless consists of a base module, at least one controller module with two or six independent control circuits and a corresponding number of room temperature sensors. The controller modules can be interconnected in a modular way to account for the number of control circuits/rooms. One room temperature sensor is required per control circuit; the standard version is battery-less and connected to the controller module via the EnOcean® wireless technology. The room temperature sensor measures the actual temperature in the room. The reference temperature is adjusted via the rotary knob of the room temperature sensor or via the app AFRISOhome. The controller module compares the actual temperature and the reference temperature and controls the volume flow of the heating/cooling water via the thermostatic actuators of the manifold system.

The base module features two independently programmable switching channels for temperature reduction, nine programmable memory blocks and a valve and pump protection function. The additional pump running time is adjustable. The terminals of the controller modules are colour-coded for easy assignment to the wires of the thermostatic actuators; in conjunction with the DIN rail snap connectors at the rear of the housing, this facilitates installation.

With an AFRISOhome gateway, it is possible to remotely check and, if necessary, adjust the room temperatures via the AFRISOhome app (for example, when coming back from winter vacation). This flexible remote control of the room temperature combines multiple benefits: You can increase living comfort and reduce energy costs.

In conjunction with additional AFRISO smart home products with EnOcean® wireless technology, the user can configure a whole range of fully customisable, extensible applications.

Functions **Base module BM**

- Power supply of the thermostatic actuators (AC 230 V)
- Switchover of the system to "Heating" or "Cooling"
- Control of the heating/cooling pumps

Controller module

- Comparison of actual and reference temperatures
- Control of heating/cooling water via connected thermostatic actuators
- Connection of two or six control circuits, extensible
- Connection to room temperature sensors via EnOcean® wireless technology

Single room temperature controller CosiTherm® – wireless

Technical specifications

Connections

Base module BM

Max. 9 controller modules F2 or
3 controller modules F6

Controller module F2

Max. 2 room temperature sensors and
8 actuators as well as external antenna

Controller module RM F6

Max. 6 room temperature sensors and
24 actuators as well as external antenna

Operating temperature range

Ambient/storage: -10/+60 °C

EnOcean® wireless

Frequency: 868.3 MHz

Transmission power: Max. 10 mW

Range: 10 to 30 m (depending on room
arrangement and materials in the
building)

Base module BM

Supply voltage

AC 230 V, 50–60 Hz

Nominal power

1 VA

Housing

Plastic housing PC/ABS

Colour: Light grey, similar to RAL 7047

W x H x D: 122 x 92 x 45 mm

Degree of protection: IP 20 (EN 60529)

Weight

215 g

Controller module

Supply voltage

AC 230 V (via base module BM)

Nominal power

Controller module F2: 0.3 W

Controller module F6: 0.5 W

Housing (W x H x D)

Plastic housing PC/ABS

Controller module F2: 3 x 92 x 45 mm

Controller module F6: 162 x 92 x 45 mm

Degree of protection: IP 20 (EN 60529)

Weight

Controller module F2: 130 g

Controller module F6: 260 g

5



See operating instructions for detailed information on the range of the EnOcean® wireless module.

DG: G, PG: 4	Part no.	Price €
Base module BM	78112	
Controller module F2A with external antenna, for 2 control circuits	78123	
Controller module F6A with external antenna, for 6 control circuits	78124	

Single room temperature controller CosiTherm® – wireless



Types and dimensions (mm)

Base module BM

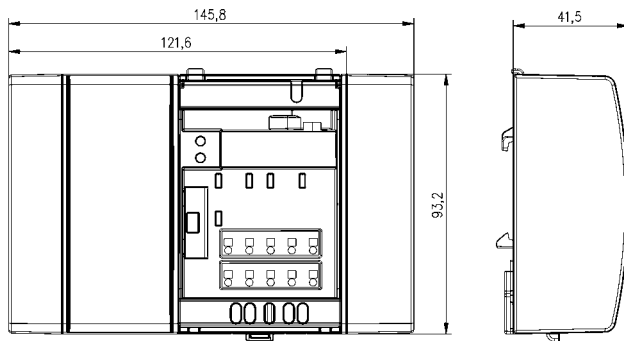

Controller module F2

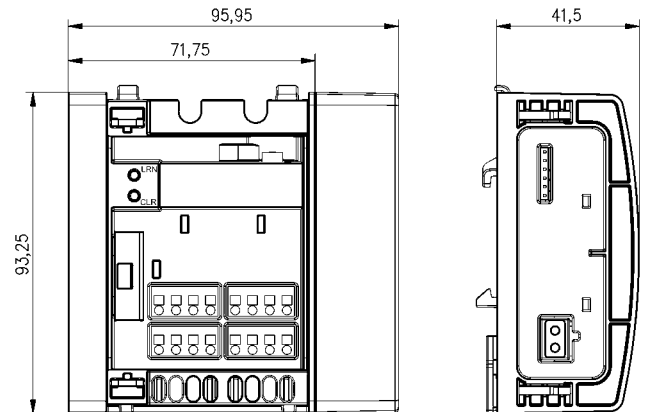

Controller module F6

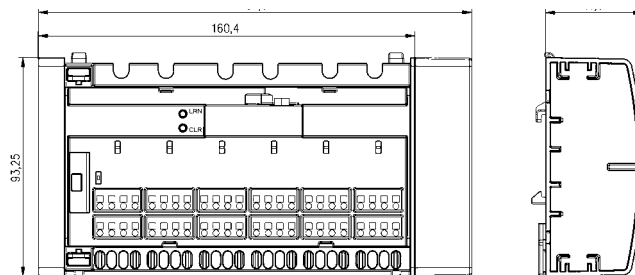

Room temperature sensor FT/FTF – wireless

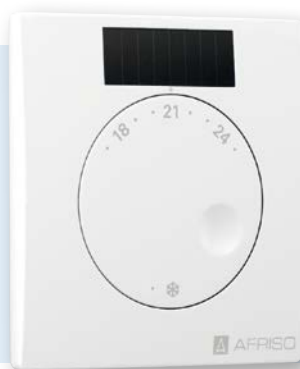

- Extremely flat with a height of 12.5 mm
- No cables required (operation via photovoltaic cell or battery)
- Flexible location-independent use anywhere in buildings

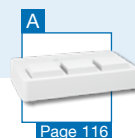
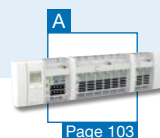

5 red dot award 2014
winner

Application Determination of the actual ambient temperature and adjustment of the reference value for the room temperature.

Description The room temperature sensor FT transmits the actual ambient temperature as well as the reference room temperature via the integrated EnOcean® wireless module to the single room temperature controller CosiTherm® Wireless or to the AFRISOhome gateway. The room temperature sensor FTF also transmits the current humidity value. The reference value for the room temperature is adjusted by means of the integrated rotary knob.

The actual temperature in rooms with an underfloor heating system is compared to the reference temperature on an ongoing basis. If there is a difference, the single room temperature controller CosiTherm®

Wireless adapts volume flows of the heating/cooling water via the thermostatic actuators of the manifold system. The energy required to send reference temperature and actual temperature values is generated by means of an integrated photovoltaic cell; it is also possible to use a standard battery.

The AFRISOhome gateway transmits alarm messages and changes in temperature and/or humidity via WLAN or LAN to the person in charge (for example, to the owner, the facility manager, the janitor or other configured contacts); the message includes information on which room temperature sensor has signalled the change. The AFRISOhome gateway in conjunction with additional AFRISO smart home products with EnOcean® wireless technology allows the user to configure a whole range of fully customisable, extensible applications.

Technical specifications

Operating temperature range

Ambient: -20/+60 °C
Storage: -20/+60 °C

Temperature adjustment range

8/30 °C

Temperature measurement

0/40 °C

Accuracy: ±1 K

Humidity measurement

With room temperature sensor FTF only

Room humidity: 0/100 % r.h.

Accuracy: ±5 % r.h.

Supply voltage

Energy harvesting (via photovoltaic cell) or type 1632 battery, DC 3 V (with daylight less than 200 lx)

Housing

Plastic housing PC

Colour: White, similar to RAL 9003

W x H x D: 78 x 82.5 x 12.5 mm

Weight: 43 g

Degree of protection: IP 30 (EN 60529)

EnOcean® wireless

EEP: A5-10-03 (FT) or A5-10-12 (FTF)

Frequency: 868.3 MHz

Transmission power: Max. 10 mW

Range: 10 to 30 m (depending on room arrangement and materials in the building)

Scope of delivery

- Room temperature sensor FT/FTF
- 4 x adhesive dots
- Without battery

Necessary additional components

- CosiTherm® Wireless and/or
- AFRISOhome gateway

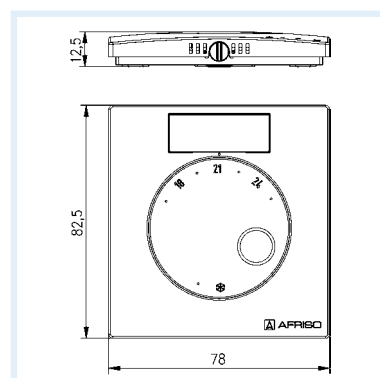

See operating instructions for detailed information on the range of the EnOcean® wireless module.

DG: L, PG: 4	Part no.	Price €
Room temperature sensor FT (temperature)	78111	
Room temperature sensor FTF (temperature, humidity)	78119	

Wireless transmitter FTM T/TF for temperature and/or humidity



- Flexible location-independent use anywhere in buildings
- Wireless transmission, cyclically (function check and transmission of values)
- No cables required (operation via photovoltaic cell or battery)
- Easy mounting via wall bracket



Wall bracket FTM with snap-on mounting.

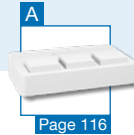

Application Determination of the ambient temperature and air humidity at a defined location.

Description The temperature sensor FTM T transmits the current ambient temperature via the integrated EnOcean® wireless module to the AFRISOhome gateway. The temperature and humidity sensor FTM TF also transmits the value of the current air humidity. Based on the event message, the AFRISOhome gateway can trigger measures. The energy required to send a wireless telegram is generated by means of the integrated photovoltaic cell. An optional battery can be used for application in darker rooms. The ambient temperature can be readjusted via the single room temperature controller CosiTherm® Wireless in order to keep the room temperature from rising or falling. The AFRISOhome gateway transmits alarm messages and changes in temperature and/or humidity via WLAN or LAN to the person in charge (for example, to the owner, the facility manager, the janitor or other configured contacts); the message includes information on which temperature sensor has signalled the change. The AFRISOhome gateway in conjunction with additional AFRISO smart home products with EnOcean® wireless technology allows the user to configure a whole range of fully customisable, extensible applications.

Technical specifications

Operating temperature range

Ambient: 0/40 °C
Storage: -20/+60 °C

Measuring range

Temperature: 0/40 °C
Accuracy: ±1 K
Humidity: 0/100 % r.h.
Accuracy: ±5 % r.h.

Supply voltage

Energy harvesting (via photovoltaic cell)
or 1/2 AA lithium battery, DC 3.6 V
(with daylight less than 200 lx)

Housing

Colour: White, similar to RAL 9003
W x H x D: 52 x 40 x 17 mm
Weight: 24 g
Degree of protection: IP 30 (EN 60529)

EnOcean® wireless

EEP: A5-02-05 (FTM T) or
A5-04-01 (FTM TF)
Frequency: 868.3 MHz
Transmission power: Max. 10 mW
Range: 10 to 30 m (depending on room
arrangement and materials in the
building)

Scope of delivery

- Temperature sensor
- Wall bracket
- 2 x adhesive dots
- Without battery

Necessary additional components

- CosiTherm® Wireless and/or
- AFRISOhome gateway

i

See operating instructions for detailed information on the range of the EnOcean® wireless module.

DG: L, PG: 4	Part no.	Price €
Temperature sensor FTM T	78144	
Temperature and humidity sensor FTM TF	78145	

Temperature and humidity sensor FTM 20 TF



- **Maintenance-free battery-less operation**
- **Solar-operated energy storage module for several days of operation even in darkness**
- **Either easy adhesive mounting or placement by means of base**
- **Battery operation optionally possible**

FTM 20 TF
with base and
triangular cover



5

Application Wireless sensor for determination of the ambient temperature and air humidity at a defined location and transmission to AFRISOhome gateway.

Description The temperature sensor FTM 20 TF measures the ambient temperature and the humidity at regular intervals. Significant changes of the sensor data are immediately transmitted to the AFRISOhome gateway; they can be used as parameters to control actuators such as the radiator actuators AVD 30 or extractor fans with EnOcean wireless technology.

The energy required to send a wireless telegram is generated by means of the integrated photovoltaic cell. The integrated energy storage module allows for several days of operation even in total darkness. In permanently dark environments (such as basements or warehouses) it is also possible to use a button cell battery.

A double-sided adhesive strip allows for extremely easy mounting of the compact housing to walls or furniture. It is possible to plug on a metal plate which serves as a base for placing the sensor on a shelf, a window sill or a sideboard.

The AFRISOhome gateway in conjunction with additional AFRISO smart home products with EnOcean® wireless technology allows the user to configure a whole range of fully customisable, extensible applications.

Technical specifications

Operating temperature range

Ambient: -20/+60 °C

Measuring range

Temperature: -20/+60 °C

Accuracy: ±0.5 K

Humidity: 0/100 % r.h.

Accuracy: ±4.5 % r.h.

Supply voltage

Energy harvesting (via photovoltaic cell) or CR 1225 button cell

Housing

Colour: White, similar to RAL 9010

W x H x D: 76.2 x 22 x 15 mm

Weight: 20 g

Degree of protection: IP 40 (EN 60529)

Operation start up time with empty energy storage module

Typically: 2.5 min at 400 lx/25 °C

EnOcean® wireless

EEP: A5-04-03

Frequency: 868.3 MHz

Transmission power: Max. 10 mW

Range: 10 to 30 m
(depending on room arrangement and materials in the building)

Scope of delivery

- Temperature sensor
- Cap triangular or quadrangular
- Base
- 1 x adhesive tape/wall bracket
- Without battery

Necessary additional components

- AFRISOhome gateway



See operating instructions for detailed information on the range of the EnOcean® wireless module.

DG: L, PG: 4	Part no.	Price €
Temperature and humidity sensor FTM 20 TF	61255	

Bidirectional wireless radiator actuator AVD 30



- Battery-less control of radiators
- Maintenance-free without additional operating costs
- Connection M30 x 1.5: Easy replacement of existing thermostat heads
- Low-noise operation

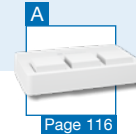

Application For wireless and battery-less temperature control in individual rooms. Ideal for heating, ventilation and air conditioning systems. Adjustments are made exclusively via the AFRISOhome app or via a central operating unit.

Description Wireless, bidirectional radiator actuator AVD 30 based on EnOcean® wireless with integrated frost protection function. AVD 30 requires no batteries; to generate the energy required for operation and communication between the AFRISOhome gateway it uses the temperature difference between the room and the radiator. An internal energy storage module helps to prevent conditions with insufficient energy supply during operation. If the energy storage module is empty, the actuator opens the radiator valve by 50 % and switches to idle state. Once a sufficient volume of heating water flows, AVD 30 starts automatically and resumes controlling the room temperature. In sparsely heated rooms, it may be necessary to charge the energy storage module via the integrated micro USB port; the actuator triggers a corresponding alarm on time.

AVD 30 controls, for example, the room temperature in a room with radiators. For this purpose, the actual temperature is measured directly at the actuator or with an additional room temperature sensor. The reference temperature can be set, for example, via the AFRISOhome app in combination with an AFRISOhome gateway. The actual temperature and the reference temperature are compared in the AFRISOhome gateway and necessary change requests are transmitted to the actuator at regular intervals. Additional configurable conditions can be included in the temperature control (for example, temperature reduction if a window is open or in the case of absence). This flexible control of the room temperature combines multiple benefits: you can increase living comfort and reduce energy and operating costs.

Technical specifications

Drive

Valve stroke: Max. 4.5 mm
Adjustment time: 0.24 mm/s
Actuating force: Max. 80 N

Supply voltage

Energy harvesting via temperature difference radiator <-> room

Housing

W x H x D: 60 x 63 x 59.5 mm
Weight: Approx. 225 g
Degree of protection: IP 30 (EN 60529)

Connection

M30 x 1.5 mm

EnOcean® wireless

EEP: A5-20-1
Frequency: 868.3 MHz
Transmission power: Max. 10 mW
Range: 10 to 30 m
(depending on room arrangement and materials in the building)

Necessary additional components

- AFRISOhome gateway

i

See operating instructions for detailed information on the range of the EnOcean® wireless module.

DG: L, PG: 4	Part no.	Price €
Bidirectional wireless actuator AVD 30	75008	

CO₂ sensor



- Monitoring of room air quality
- Compact, unobtrusive design
- Visual indication of concentration
- Mains plug version similar to Schuko® CEE mains plug
- With or without EnOcean® wireless technology



Flexible use in buildings due to integrated mains plug.

5

Application For continuous monitoring of the carbon dioxide (CO₂) concentration in the ambient air. Application in rooms in which many persons work, study or live and where carbon dioxide levels may consequently be elevated. High concentrations of carbon dioxide in the ambient air reduce the ability of persons to concentrate and perform. Ideal for educational institutions, training/meeting rooms, office areas and household.

Description CO₂ sensor with infrared technology in plastic housing, for connection to a standard CEE socket. The CO₂ concentration in the room air is indicated directly at the device by a colour scale:

- LED green: No ventilation required
- LED yellow: Ventilation recommended
- LED red: Ventilation required

The version CO₂ sensor F (with EnOcean® wireless module) sends the measured values to the AFRISOhome gateway for further processing and initiation of appropriate action. For example, it is possible to start a room ventilation system in order to reduce the CO₂ concentration. The current carbon dioxide concentration is also displayed by the app AFRISOhome. The AFRISOhome gateway in conjunction with additional AFRISO smart home products with EnOcean® wireless technology allows the user to configure a whole range of fully customisable, extensible applications.

Version CO₂ sensor: Version without wireless transmission as stand-alone solution.

Technical specifications

Measuring range

0/2,000 ppm

Measuring accuracy

400/1,250 ppm: ±30 ppm or ±3 %
of measured value
1,250/2,000 ppm: ±30 ppm or ±5 %
of measured value

Operating temperature range

Ambient: 0/50 °C
Storage: -40/+70 °C
Humidity: Max. 95 % r.h.

Housing

Plastic housing (PC/ABS),
Colour: White, similar to RAL 9003
W x H x D: 69 x 69 x 31 mm
Weight: 108 g
Degree of protection: IP 20 (EN 60529)

Supply voltage

AC 100–240 V via Schuko® mains socket

Nominal power

2.5 VA

Visual indication

LED green: < 1,000 ppm CO₂
LED yellow: 1,000–1,500 ppm CO₂
LED red: > 1,500 ppm CO₂

EnOcean® wireless

EEP: A5-09-09
Frequency: 868.3 MHz
Transmission power: Max. 10 mW
Range: 10 to 30 m (depending on room arrangement and materials in the building)

Necessary additional components

- AFRISOhome gateway

i

See operating instructions for detailed information on the range of the EnOcean® wireless module.

DG: L, PG: 4	Part no.	Price €
CO ₂ sensor F, with EnOcean® wireless module	61240	
CO ₂ sensor, without wireless module	61241	

Universal wireless transmitter FTM



- Equipment can be integrated into building automation systems via voltage-free contact
- Transmitters for a wide range of AFRISO probes
- Compact design

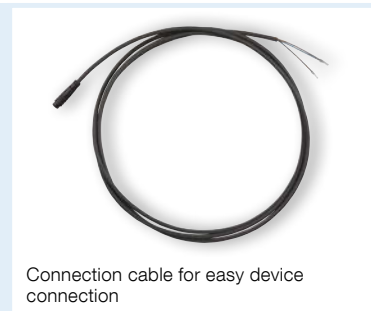

Connection cable for easy device connection



Page 118



Page 116



Page 119

5

Application Monitoring of the switching states of voltage-free contacts. In addition, transmission of ambient temperature.

Description The universal wireless transmitter can integrate any device with a voltage-free contact into a building automation system. Examples comprise the alarm relays of heating systems or status messages of alarm systems. The voltage-free contact is supplied with voltage by the universal wireless transmitter. A defined recipient is immediately notified of each state transition via EnOcean® wireless. The universal wireless transmitter is used as a transmission unit for many AFRISO probes such as Minimelder or Maximelder, pressure gauges with electrical contact, etc. The energy required to send the message with the state transition is generated by means of an integrated photovoltaic cell; it is also possible to use a battery in dark rooms. The AFRISOhome gateway transmits alarm messages and state transition messages via WLAN or LAN to the person in charge (for example, to the owner, the facility manager, the janitor or other configured contacts); the message includes information on which universal wireless transmitter FTM has signalled the state transition. The AFRISOhome gateway in conjunction with additional AFRISO smart home products with EnOcean® wireless technology allows the user to configure a whole range of fully customisable, extensible applications:

- Floor water probe (for water detection)
- Minimelder (for signalling minimum levels in tanks)
- Maximelder (for signalling maximum levels in tanks)
- Pressure gauge with electrical contact (for signalling limit values)

Technical specifications

Operating temperature range

Ambient: 0/40 °C
Storage: -20/+60 °C

Temperature measuring range

Measuring range: 0/40 °C
Accuracy: ±1 K

Supply voltage

Energy harvesting (via photovoltaic cell) or 1/2 AA lithium battery, DC 3.6 V (with daylight less than 200 lx)

Housing

Colour: White, similar to RAL 9003
W x H x D: 52 x 40 x 17 mm
Weight: 22 g
Degree of protection: IP 54 (EN 60529)

EnOcean® wireless

EEP: A5-30-03
Frequency: 868.3 MHz
Transmission power: Max. 10 mW
Range: 10 to 30 m (depending on room arrangement and materials in the building)

Scope of delivery

- Universal wireless transmitter FTM
- Wall bracket
- 2 x adhesive dots
- Without battery

Necessary additional components

- AFRISO probe with plug-in connector (see accessories)
- AFRISOhome gateway

i

See operating instructions for detailed information on the range of the EnOcean® wireless module.

DG: L, PG: 4	Part no.	Price €
Universal wireless transmitter FTM	78143	
Connection cable 2 m	78974	

Wireless rocker switch FT4F-rw

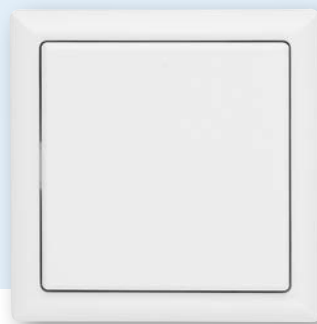

- **Energy harvesting:** Generates the energy for the wireless telegram when button is pressed
- **No battery, no connection cable required**
- **Flexible and location-independent use**

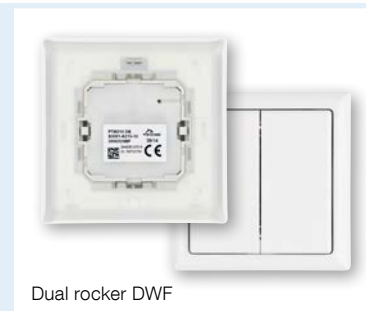

Dual rocker DWF



Page 98



Page 118

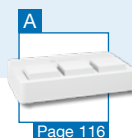

Page 116

5

Application For switching wireless actuators. The switch automatically generates the energy required for wireless telegrams when the switch is operated. Connection cables or batteries are not required.

Description Flexible use with single or dual rocker. If a single rocker is used, two signals can be transmitted: Top part of rocker pressed, bottom part of rocker pressed. Switches with dual rockers can transmit four signals: Two rockers, top and bottom parts pressed. The holding plate can be screwed to a plane surface or glued to walls, glass or furniture by means of the enclosed adhesive film. The unit can also be easily screwed to an existing 55 mm switch box using the existing screw sockets. It is possible to directly establish a wireless connection of the wireless rocker switch to many EnOcean® actuators such as the water valve WaterControl or the indoor siren AIS 10 PRO. The wireless rocker switch can also be operated as a component of the AFRISOhome gateway.

Technical specifications

Supply voltage

Energy harvesting (via press of button)

Housing

Colour: White, similar to RAL 9003
W x H: 80 x 80 mm, outside
63 x 63 mm, inside dimensions of frame
15 mm height

EnOcean® wireless

EEP: RPS
Frequency: 868.3 MHz
Transmission power: Max. 10 mW
Range: 10 to 30 m (depending on room arrangement and materials in the building)

Scope of delivery

- Frame R1F
- 1 x rocker WF
- 1 x dual rocker DWF
- 1 x frame BRF
- 1 x plate HP
- 1 x wireless module
- 1 x adhesive film



See operating instructions for detailed information on the range of the EnOcean® wireless module.

DG: L, PG: 4	Part no.	Price €
Rocker switch FT4F-rw	78972	

Door and window contact AMC 20



- Maintenance-free battery-less operation
- Solar-operated energy storage module for several days of operation even in darkness
- Easy adhesive mounting at doors and windows
- Battery operation optionally possible



Page 114



Page 118



Page 116



5

Application Magnetic contact sensor for monitoring the states OPEN and CLOSED and for transmission to the AFRISOhome gateway or to stand-alone wireless components such as the indoor siren AIS 10 PRO.

Description The door and window contact AMC 20 is a battery-less, maintenance-free magnetic contact wireless module. The energy required to send an EnOcean® telegram is generated by means of an integrated photovoltaic cell. The integrated energy storage module allows for several days of operation even in total darkness. In permanently dark environments (such as basements or warehouses) it is also possible to use a button cell battery. The module monitors the presence of a magnet at the side by means of an integrated Reed contact and signals state changes. A double-sided adhesive strip or the enclosed bracket allow for extremely easy mounting of the compact housing to windows, door frames or cabinet doors.

The AFRISOhome gateway in conjunction with additional AFRISO smart home products with EnOcean® wireless technology allows the user to configure a whole range of fully customisable, extendable applications.

Technical specifications

Operating temperature range

Ambient: -25/+65 °C

Supply voltage

Energy harvesting
(via photovoltaic cell)
or CR -1225 button cell

Housing

Colour: White, similar to RAL 9010
Grey, similar to RAL 7016

Reed contact: 76.2 x 22 x 15 mm

Magnet housing: 20 x 10 x 1.5 mm

Weight: 20 g

Degree of protection: IP 40 (EN 60529)

Reed contact

1 x integrated

Operation start up time with empty energy storage module

Typically: 2.5 min at 400 lx/25 °C

EnOcean® wireless

EEP: D5-00-01

Frequency: 868.3 MHz

Transmission power: Max. 10 mW

Range: 10 to 30 m
(depending on room arrangement
and materials in the building)

Scope of delivery

- Door and window contact
- Magnet
- Adhesive tape/wall bracket
- 1 x mounting bracket

i

See operating instructions for detailed information on the range of the EnOcean® wireless module.

DG: L, PG: 4	Part no.	Price €
Door and window contact AMC 20, white, similar to RAL 9010	61254	
Door and window contact AMC 20, grey, similar to RAL 7016	61258	

Indoor siren AIS 10



- Compact, unobtrusive design
- Mains plug version similar to Schuko CEE mains plug
- Loud 90 dB alarm tone
- Integrated repeater function



Page 118



Page 116

5

Application Can be used as a stand-alone solution with EnOcean® wireless products or integrated in Smart Home systems as an alarm siren.

Description The indoor siren AIS 10 allows for versatile use in building technology applications. As a mains plug version, you can plug it into any power outlet and the siren is ready for operation. AIS 10 can be used in a variety of scenarios and programs, for example, as an audible alarm unit in the case of absence or at night when doors or windows are opened which are equipped with door or window contacts (such as AMC 20). The indoor siren also features an integrated repeater for the EnOcean wireless network. This function can be selected in the AFRISOhome app.

Technical specifications

Operating temperature range

Ambient: 0/50 °C
Storage: -40/+70 °C
Humidity: Max. 95 % r.h.,
non-condensing

Housing

Plastic housing (PC/ABS)
Colour: White, similar to RAL 9003
W x H x D: 69 x 69 x 31 mm
Weight: 120 g

Supply voltage

AC 100–240 V via Schuko® mains socket

Nominal power

2.5 VA

Alarm condition

Sound pressure: 90 dB

Visual indication

LED red: Visual alarm
LED green: Operation

EnOcean® wireless

EEP: Generic Profile (GP)
Frequency: 868.3 MHz
Transmission power: Max. 10 mW
Range: 10 to 30 m (depends on room
arrangement and materials in the building)

Necessary additional components

- AFRISOhome gateway

i

See operating instructions for detailed information on the range of the EnOcean® wireless module.

DG: L, PG: 4	Part no.	Price €
Indoor siren AIS 10	61242	

Indoor siren AIS 10 PRO



- Ideal as a stand-alone device for setting up a modular alarm system without a gateway
- Compact, unobtrusive design
- Version with mains plug
- Loud 90 dB alarm tone
- Integrated repeater function



5

Application Alarm siren as a stand-alone solution for EnOcean® wireless products. You can teach in up to 20 EnOcean® wireless smart home devices into the siren. AIS 10 PRO allows you to create a modular alarm system with or without a gateway or a mobile device.

Description The indoor siren AIS 10 PRO allows for versatile use in building technology applications. As a mains plug version, you can plug it into any power outlet and the siren is ready for operation. The siren lets you teach in up to 20 smart home sensors via EnOcean® wireless. This includes, among others, door and window contacts, water sensors, smoke alarms, switches, universal wireless transmitters, window handles, AFRISO WATCHDOG-LINE alarm units and additional AFRISO AIS 10 PRO series indoor sirens for alarm on additional floors. If one of the connected EnOcean® devices responds, a radio signal is sent to the indoor siren. The alarm signals from the corresponding sensor are repeated at intervals of one second to ensure reliable transmission. The indoor siren AIS 10 PRO emits a loud alarm tone and the LED lights red.

The following alarm scenarios can be distinguished:

Pre-alarm: LED red and beeping sound 1 x per second. After 5 seconds transition to main alarm.

Main alarm: LED red and 90 dB continuous alarm sound for 5 minutes. Finally, transition to post-alarm.

Post-alarm: LED red and beeping sound 1 x per 5 seconds.

Once the cause of the alarm has been removed, the alarm tone is muted and the LED lights green. In addition, AIS 10 PRO can be operated as a component of the AFRISOhome gateway. If the device is operated as a stand-alone alarm system, the wireless rocker switch FT4F-rw must be integrated as an activation switch. The alarm system can operate in the operating states ACTIVE and NOT ACTIVE, depending on the presence of the persons in the building. In the operating state NOT ACTIVE, the LED lights green, in the operating state ACTIVE, it lights yellow. In the operating state NOT ACTIVE, only safety-related sensors such as water sensors, smoke alarms, rocker switches (used as "panic buttons") or WATCHDOG-LINE alarm units trigger an alarm. In addition, AIS 10 can be operated as a component of the AFRISOhome gateway. The siren can be controlled via a mobile device. AIS 10 PRO also features a repeater function. When operated with an AFRISOhome gateway, the indoor siren also monitors the mains voltage. In the case of power outage, an alarm signal is sent to a master network.

Technical specifications

Operating temperature range

Ambient: 0/50 °C
Storage: -40/+70 °C
Humidity: Max. 95 % r.h., non-condensing

Housing

Plastic housing (PC/ABS)
Colour: White, similar to RAL 9003
W x H x D: 69 x 69 x 31 mm
Weight: 120 g
Degree of protection: IP 20 (EN 60529)

Supply voltage

AC 100–240 V via Schuko® mains socket

Nominal power

2.5 VA

Alarm condition

Sound pressure: 90 dB

Visual indication

LED red: Alarm
LED yellow: Alarm system ACTIVE
LED green: Operation, alarm system NOT ACTIVE

EnOcean® wireless

EEP: Generic Profile (GP)
Frequency: 868.3 MHz
Transmission power: Max. 10 mW
Range: 10 to 30 m (depends on room arrangement and materials in the building)



See operating instructions for detailed information on the range of the EnOcean® wireless module.

DG: L, PG: 4	Part no.	Price €
Indoor siren AIS 10 PRO	61256	

AFRISOhome gateway HG 02



- Base module of your building management system
- Communication via EnOcean® and WLAN
- Versatile combinations of products of the EnOcean®, Z-Wave and Zigbee Alliance
- Voice control with Alexa (Amazon Echo)



Page 118

5

Application For controlling and managing wireless sensors and actuators with EnOcean® und WLAN technology. Events, messages and measured values are documented, and alarms are transmitted to mobile devices (smartphones), if necessary. Ideal as control centre of a smart home system in apartments and single-family homes.

Description The AFRISOhome gateway HG 02 is the control centre of your smart home. The app (iOS, Android und WebApp) allows you to add and control a large variety of compatible devices (see whitelist at www.afrisohome.com) to the smart home. A WLAN interface is provided for Internet access and communication with routers and smartphones. It is also possible to operate the AFRISOhome gateway without Internet connection. In this case, an independent WLAN network is created. All user data and passwords are stored and processed locally on the AFRISOhome gateway. Three slots are available that allow you to integrated additional wireless standards by means of an extension module. Currently, Zigbee and Z-Wave are provided. The free AFRISOhome app for iOS and Android allows for fast and easy operation of the gateway. Smart home systems based on an AFRISOhome gateway excel with virtually unlimited customisability and extensibility.

Technical specifications

Operating temperature range

Ambient: 0/40 °C
Storage: -20/+60 °C

Supply voltage

AC 100–240 V
Frequency: 50–60 Hz

Housing

W x H x D: 205 x 46.1 x 146 mm

EnOcean® wireless

Frequency: 868.3 MHz
Transmission power: Max. 10 mW
Range: 10 to 30 m (depending on room arrangement and materials in the building)

Scope of delivery

- Gateway HG 02 with neutral cubes as covers
- Power supply unit

i

Complete whitelist of all compatible products on www.afrisohome.com



AFRISOhome gateway HG 02

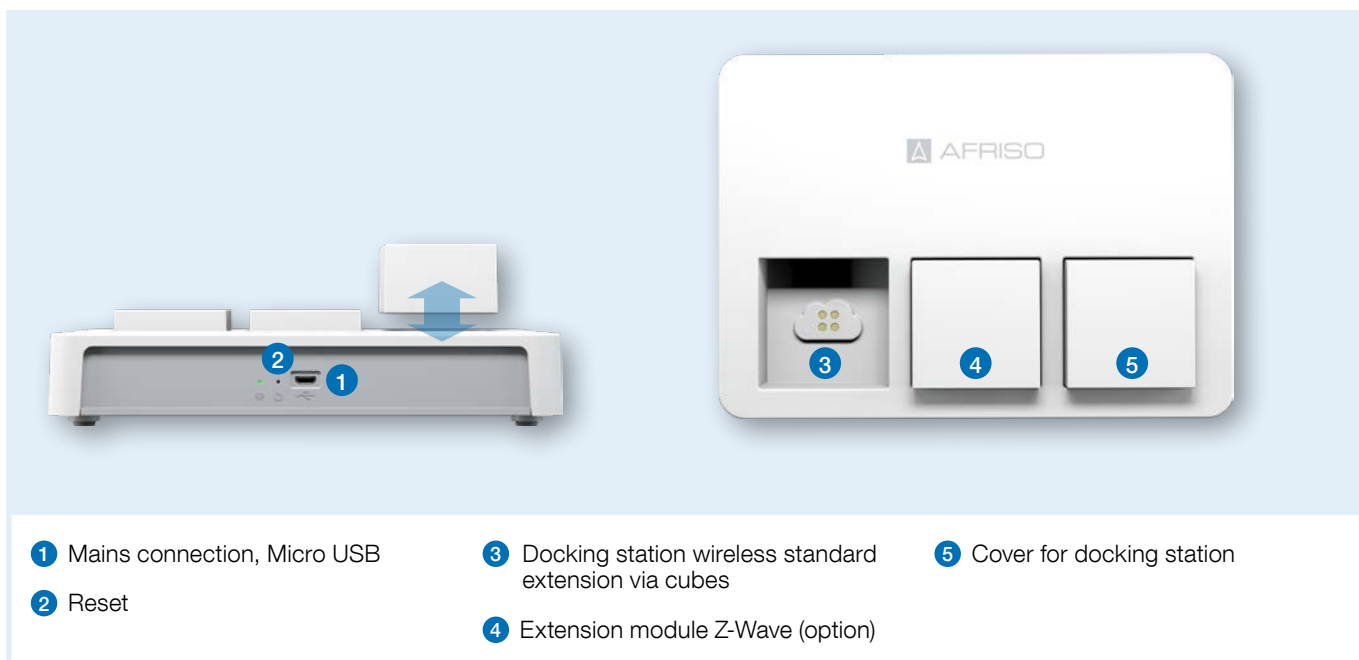

5

- 1 Mains connection, Micro USB
- 2 Reset
- 3 Docking station wireless standard extension via cubes
- 4 Extension module Z-Wave (option)
- 5 Cover for docking station

Smart Home with AFRISOhome gateway



i See operating instructions for detailed information on the range of the EnOcean® wireless module.

DG: L, PG: 4	Part no.	Price €
AFRISOhome gateway HG 02 with WLAN and wireless module EnOcean®	78102	
Accessories		
Extension module Zigbee for HG 02	78103	
Extension module for Z-Wave for HG 02	78104	

Mobile app AFRISOhome

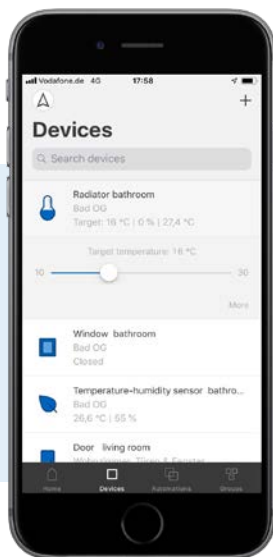

- Intuitive mobile app for AFRISOhome gateways
- Location-independent status checks and operation of the building automation system
- Operating systems: iOS and Android
- Web App

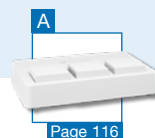

5

Application User interface for mobile devices such as tablets or smartphones to control and visualise all AFRISO smart home building automation sensors and actuators. The AFRISOhome app allows for integration and interoperation of devices based on the wireless standards EnOcean®, Z-Wave, WLAN and Zigbee. This allows for almost limitless automation. Visit www.afrisohome.com for a detailed list of devices.

Description All wireless devices, sensors and actuators integrated into a smart home system can be easily divided into groups by means of AFRISOhome gateways. Actuators in rooms, buildings, etc. can be defined as groups. The access rights for the various groups can be configured separately for mobile devices. After selection of a group, the display of the mobile device shows the various wireless products. The user is provided with a clear overview of the current situation of the smart home system. Logic states, temperature values, information on the air quality and buttons for the actuators are displayed, among other things.

AFRISOhome gateways with the AFRISOhome app provide for countless combination possibilities in wireless building automation. AFRISO offers reliable, safe and innovative devices with EnOcean® wireless modules. It is also possible to integrate other products of the EnOcean® Alliance into your building automation system. With currently more than 80 compatible devices, the AFRISOhome gateway HG 02 provides great versatility. Along with the optional extension modules Z-Wave and Zigbee, the AFRISO smart home integrates more than 250 devices.

App structure



Teaching in devices

Function groups

Function automation

Test the demo app.

Accessories and spare parts for AFRISO smart home

PG: 4	Description	Suitable for								Part no.	DG	Price €
		WaterSensor con/ WaterSensor BWS	Room temperature sensor FT/FTF	Wireless transmitter FTM	Smoke alarm ASD 10/ASD 20	WATCHDOG-LINE alarm units	CostTherm® wireless	AFRISOhome gateway HG 01				
	1/2 AA lithium battery	•		•	•					78100	L	
	CR -1632 button cell		•							78132	G	
	Extension cable Cable length: 2 m	•		•						78141	L	
	Connection cable Cable length: 2 m Connector: One end for FTM, other end flying leads			•						78974	L	
	Adhesive antenna Cable length: 3 m Connector: Angular SMA connector							•		78175	G	
	Magnetic foot antenna Connector: Angular SMA connector							•		78167	G	
	Conductivity floor water probe con	•		•						78142	L	
	Conductivity floor water probe BWS 10-1					•				55112	H	
	Conductivity floor water probe BWS 10-2	•		•						55116	L	
	Probe Minimelder Length: 10 m Connector: For FTM			•						78147	L	
	Probe Maximelder Length: 10 m Connector: For FTM			•						78148	L	
	Repeater Switchable level 1 and level 2 mode							•		75007	L	
	Pluggable EnOcean® wireless module TCM 320 For WATCHDOG-LINE PCBs, can be ordered separately for EnOcean-ready products					•				78082	G	

Alarm units with EnOcean® wireless at a glance

With the proven WATCHDOG-LINE alarm units, AFRISO has been offering devices for reducing a vast array of risks in buildings and homes for many years. The alarm units will now successively be EnOcean®-enabled so that an EnOcean® wireless module can be retro-fitted. Whether or not an alarm unit already features this technology is indicated by the labels "EnOcean-ready" on the nameplate.

All devices of the WATCHDOG-LINE are compact units in wall mounting housings for professional and safe installation. Visual alarm and audible alarm that can be acknowledged ensure that the persons in a building are notified of the alarm condition. Residents with or without mobile devices can immediately take appropriate action. The AFRISOhome gateway in conjunction with additional AFRISO smart home products with EnOcean® wireless technology allows the user to configure a whole range of fully customisable, extensible applications.

Typical application areas





5



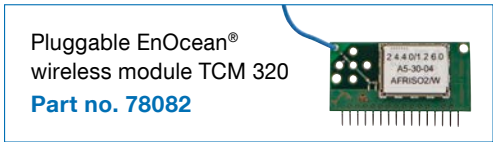







- Collection facilities below oil and water consuming equipment
- Drip pans below storage tanks, burners or motors in buildings or outdoors
- Containers, barrels and tanks/ double-walled tanks
- Sewage tanks
- Cisterns and water storage tanks
- Oil depots, boiler rooms and rooms with mains water connection
- Heating systems
- Cable and pipe ducts
- Canal shafts, manholes and inspection ducts
- Pipes and hoses



EnOcean-ready
The label "EnOcean-ready" indicates that the PCB of the device features a slot for the EnOcean® wireless module. It is sufficient to plug in the TCM 320 wireless module to integrate the device into an EnOcean® wireless building automation system.



Alarm unit	Probe	EnOcean®	Media	Application
 Water alarm unit WWG	Wall mounting rail probe WSS or  Floor water probe BWS 10-1	EnOcean-ready	<ul style="list-style-type: none"> ■ Water ■ Conductive water mixtures ■ Electrically conductive liquids ■ Emulsions 	Single-channel Suitable for water, but also for electrically conductive liquids, emulsions and conductive water mixtures. ⓘ See page 77
 Oil/water alarm unit ÖWU	 Wall mounting rail combination probe	EnOcean-ready	<ul style="list-style-type: none"> ■ Oil + water 	Single-channel ÖWU distinguishes oil alarms and water alarms and indicates the appropriate alarm condition. ⓘ See page 74

Alarm unit	Probe	EnOcean®	Media	Application
 <p>Oil/water alarm unit ÖWWG 3*</p>	 <p>PTC thermistor probe</p>	EnOcean-ready	<ul style="list-style-type: none"> Electrically conductive and non-conductive liquids 	<p>Single-channel ÖWWG 3 generates alarms in the event of accumulations of liquids caused by tank leaks, backflow, flooding, etc.</p> <p>Approval for construction products: DIBt: Z-65.40-339</p> <p>i See page 71</p>
 <p>Level switches Minimelder / Maximelder</p>	 <p>Minimelder/ Maximelder probe</p>	EnOcean-ready	<ul style="list-style-type: none"> Water Fuel oil EL, L, M Oil/water mixtures Neutral liquids 	<p>Single-channel Suitable to signal minimum or maximum levels in tanks containing liquids.</p> <p>i See page 19</p>
 <p>Digital tank contents indicator DTA 20 E</p>	 <p>Pneumatic Measuring line</p>	EnOcean-inside	<ul style="list-style-type: none"> Fuel oil Diesel fuel Water Non-corrosive media (density 0.5 to 1.5 g/cm³) 	<p>Single-channel For manual level measurement and signalling of a minimum level during measurements – battery-operated.</p> <p>i See page 100</p>
 <p>Leak detector Eurovac</p>	 <p>High- or low-vacuum based</p>	EnOcean-ready	<ul style="list-style-type: none"> Water-polluting liquids (flash point > 55 °C) AdBlue® (urea solution 32.5 %) 	<p>For monitoring aboveground or underground double-walled tanks or single-walled tanks with inner lining.</p> <p>Approval: CE mark EU Construct Products Regulation PVO 305/2011, EU 574/2014, EN 13160-1/-2 and ÜHP</p> <p>i See page 53</p>
 <p>Leak detector Europress</p>	 <p>Pressure type</p>	EnOcean-ready	<ul style="list-style-type: none"> Water-polluting liquids AdBlue® (urea solution 32.5 %) 	<p>For monitoring aboveground or underground double-walled tanks.</p> <p>Approval: CE mark EU Construct Products Regulation PVO 305/2011, EU 574/2014, EN 13160-1/-2 and ÜHP</p> <p>i See page 62</p>

* Use as leak detection system class III as per EN 13160-1/-4.



Tank withdrawal systems



Automatic
Fuel oil de-aerators



Fuel oil filters



Anti-siphon valves

CHAPTER 6

Equipment for fuel oil storage tanks and oil carrying pipes

OVERVIEW

Equipment for double-walled underground tanks 124

WITHDRAWAL SYSTEMS

Tank withdrawal system Euroflex 128

Tank withdrawal system Euroflex TH with heating band, Miniflex 130

Pull cord, pressure compensation unit DAE 131

ANTI-SIPHON VALVES

Anti-siphon valves 132

Piston type anti-siphon KAV 133

Diaphragm type anti-siphon valve MAV 134

Tester for safety-related equipment against siphoning 135

FUEL OIL FILTERS

Comparison of fuel oil filters 136

Single-line and dual-line filters for fuel oil 137

Spare parts for filters 147

FUEL OIL DE-AERATORS

Overview automatic fuel oil de-aerators 139

Fuel oil de-aerator Flow-Control 3/K 140

Fuel oil de-aerator Flow-Control 3/K HT 141

Fuel oil de-aerator FloCo-Top-1K 142

Fuel oil de-aerator FloCo-Top-1C 143

Fuel oil de-aerator FloCo-Top-2 144

Fuel oil de-aerator FloCo-Top-2CM 146

ACCESSORIES

GWG filler cap, filler cap K, pressure relief device 126

Vent caps, dip stick pipe cap/filler caps 127

Screw connections, vacuum gauges, adapters, oil filter spanners, hand-held suction pump 148

Equipment for double-walled underground tanks

Leak monitoring with vacuum

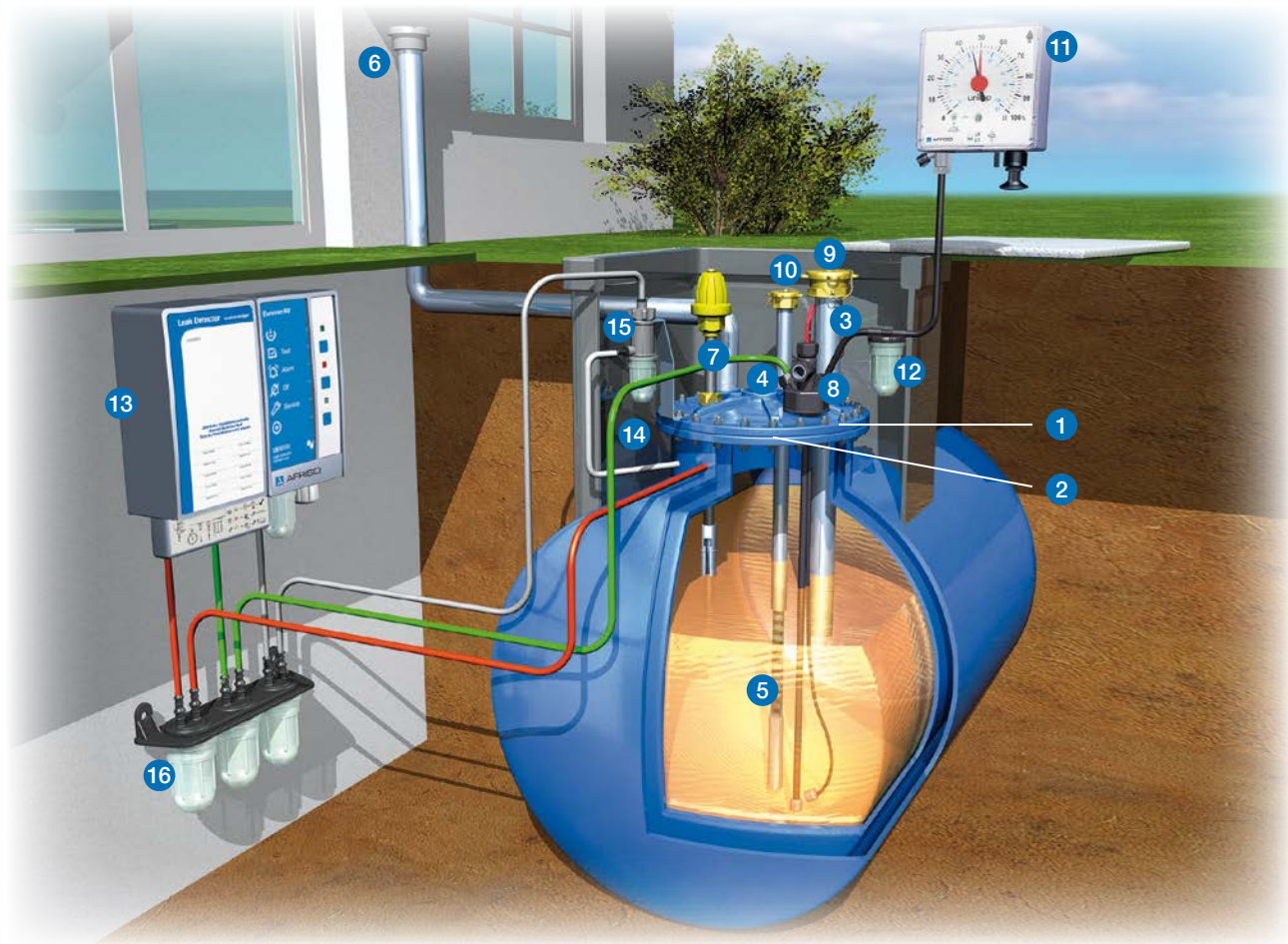

- | | | | |
|---|----------------------------------------------------------------------------|----|------------------------|
| 1 | Manhole cover | 9 | Filler cap |
| 2 | Seal | 10 | Cap for dipstick pipe |
| 3 | Filling pipe with immersion pipe | 11 | Level indicator Unitop |
| 4 | Pipe for dipstick | 12 | Condensate trap |
| 5 | Dipstick | 13 | Leak detector Eurovac |
| 6 | Vent cap | 14 | LAZ mounting kit |
| 7 | Level sensor GWG 23 | 15 | Liquid barrier |
| 8 | Combination fitting Euroflex made of plastic, also acts as isolating piece | 16 | Condensate bar |

Our product portfolio for the safe operation of fuel oil systems and fuel oil tanks reduces operating costs, helps make optimum use of fuels, provides timely warnings if hazardous situations arise and contributes to the protection of the environment. Irrespective of the tank size or the fuel to be stored.

Application areas

- Cylindrical steel or plastic (glass-fibre reinforced plastic) double-walled tanks
- Double-walled steel tanks
- Steel tanks welded on site
- Spherical tanks
- Tanks with inner lining
- Oil storage rooms/collection facilities
- Containers, cisterns, cesspits

Media

- Fuel oil EL
- Diesel fuel
- Biofuel with up to 100 % FAME
- Biodiesel with up to 100 % FAME
- AdBlue®
- AHL
- Rainwater
- Many other media

Equipment for double-walled underground tanks

Leak monitoring with leak detection fluid

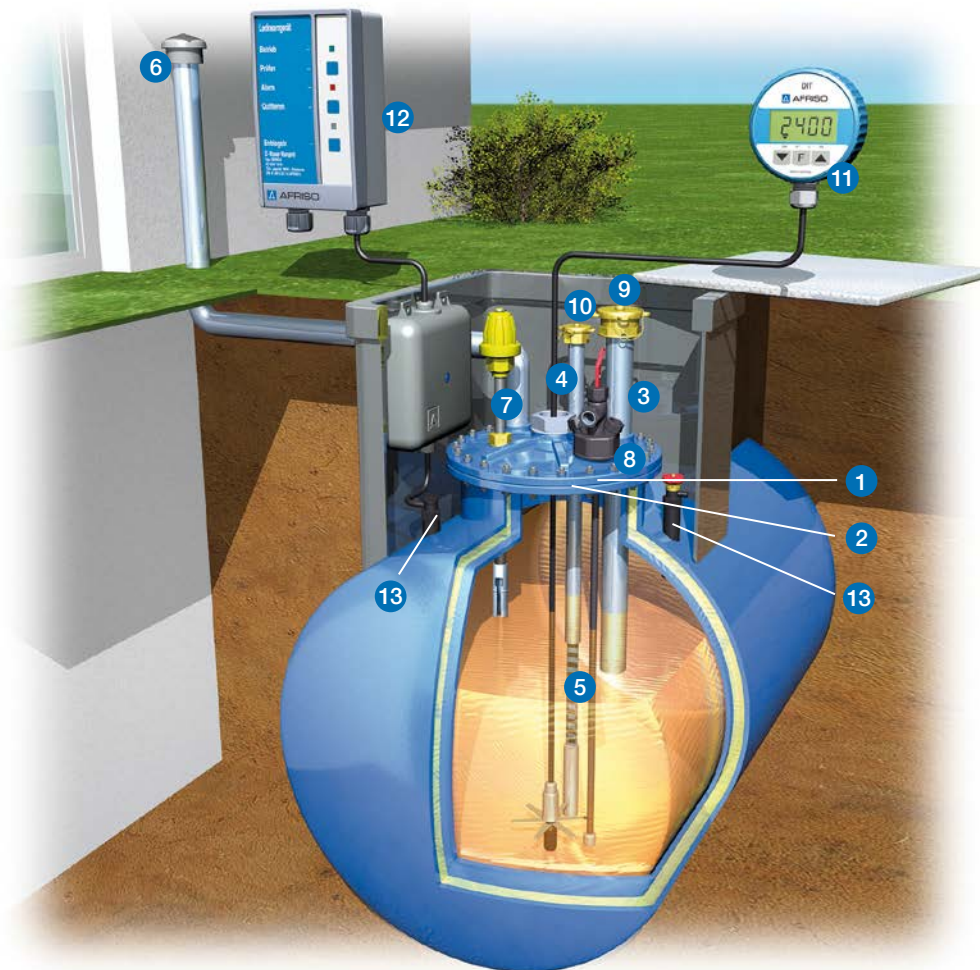

- | | | | |
|---|----------------------------------|----|---------------------------------------------------------------------------------|
| 1 | Manhole cover | 8 | Combination fitting Euroflex 3 made of plastic, also acts as an isolating piece |
| 2 | Seal | 9 | Filler cap |
| 3 | Filling pipe with immersion pipe | 10 | Cap for dipstick pipe |
| 4 | Pipe for dipstick | 11 | Level indicator DIT |
| 5 | Dipstick | 12 | Leak detector |
| 6 | Vent cap | 13 | LAG mounting kit |
| 7 | Level sensor GWG 23 | | |

Safety and protection of the oil storage system are the basis of our product development. Continuous adaptation to current standards and directives as well as intelligent products such as the piston type anti-siphon valve approved for use in manholes up to -25 °C ensure optimum safety concepts.

i

Since 2003, leak monitoring by means of systems with leak detection fluids is only permissible in the case of existing systems. New systems must be monitored with vacuum type or pressure type systems (such as Eurovac or Europress).

Accessories for GWG filler caps, pressure relief device

GWG filler cap

Application For facilities that may be operated with fuel oil EL standard and low-sulphur, diesel or biodiesel. Suitable for flood hazard areas.

Description GWG filler cap with bayonet connection G2 with integrated level sensor connection fitting. Brass male coupling as per EN 14420-6. Filler cap made of oil- and weather-resistant plastic. Watertight up to 10 m water column. Lockable with standard padlock.



GWG filler cap

Filler cap K

Application For facilities that may be operated with fuel oil EL standard and low-sulphur, diesel or biodiesel. Suitable for flood hazard areas.

Description Filler cap with bayonet connection G2. Brass male coupling as per EN 14420-6. Filler cap made of oil- and weather-resistant plastic. Lockable with standard padlock.



Filler cap K

Pressure relief device

Application To avoid overpressure of storage tanks during filling. Suitable for flood hazard areas.

Description Pressure relief device with male connection thread G1½. Opening pressure approx. 25 mbar. Two or more overpressure devices must be installed for filling rates of more than 300 l/min. Watertight up to 10 m water column.



6

i

GWG filler caps are also used in building renovation projects since the existing GWG wall fitting can no longer be fixed to the outside insulation.

DG: G	PG			Part no.	Price €
GWG filler cap	2	1	10	20430	
Filler cap K	2	1	10	20440	
Pressure relief device	1	1	25	20466	

Vent caps, dip stick pipe caps/filler caps



Vent caps

Application To cover the vent line.

Description Cap for vent line.

Metal version: Zamak alloy, thread G1½ or G2.

Plastic version: Plug-in type with fixing by means of screw or G2 male thread.

Caps for dipsticks, filler caps

To close dip stick pipes and filling pipes. Suitable for flood hazard areas.

Dip stick pipe cap/filler cap made of Zamak alloy. Watertight up to 10 m water column.

Lockable with standard padlock.

6



See page 6 for pipes for dipsticks.

DG: G	PG			Part no.	Price €
Vent cap 2", plastic – plug-in version	1	1	25	20460	
Vent cap 1½" plastic – plug-in version	1	1	25	20450	
Vent cap G2, plastic – male thread	1	-	200	20462	
Vent cap G2 metal	3	1	25	20463	
Vent cap G1½ metal	3	1	25	20455	
Cap for pipe for dipstick G1 x G1¼	2	1	140	20464	
Filler cap G2 x G2½ Fuel oil EL standard	3	1	55	20445	
Filler caps – green G2 x G2½ Low-sulphur fuel oil EL	3	1	25	20452	

Tank withdrawal system Euroflex



Suitable for use in flood hazard areas. Watertight up to 10 m water column.



Quick-action shut-off valve with lever for fast shutting off of the oil supply. Remote operation from outside of the tank room possible with pull cord.



Version Euroflex 3 with direct connection for pneumatic tank contents gauges. Ideal for retrofitting or for applications involving tanks with few connections.

6



Floating withdrawal as per DIN 4755 recommendation. Makes it possible to withdraw fuel oil in the clean area and thus supports optimum functionality of the downstream fittings (e.g. oil filters).



Version with special G1 screw connection to avoid twisting. Ideal for use with Euroflex with heating band for fast, simple mounting.

Figure: Euroflex 3 with float



Fitting made of high-strength, weather-resistant plastic. Approved as an isolating piece.



Flexible suction line for maximum variability – also in terms of hose length. The standard lengths 2.15 m and 3.15 m can be shortened as required without any problems.



All materials resistant to biofuel and biodiesel with max. 20 % FAME (fatty acid methyl ester).



Measuring line with balance chamber (for Euroflex 3).

Tank withdrawal system Euroflex



Euroflex 312

- Combination fitting made of high-strength plastic
- Integrated, TÜV-tested isolating piece
- Silent check valve
- Euroflex 3 for floating withdrawal, also for self-securing withdrawal
- Suitable for use in flood hazard areas

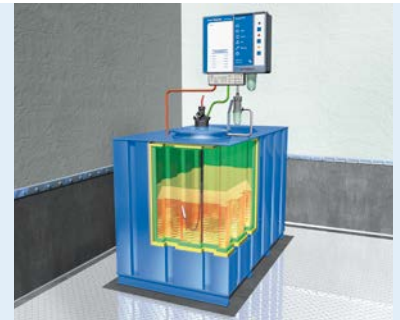

Application For withdrawal of fuel oil from underground and aboveground tanks in single-line or dual-line mode. Suitable for the following media: Fuel oil EL (DIN 51603-1) and diesel fuel (EN 590) as well as biofuel and biodiesel with max. 20 % FAME. Also for use in flood hazard areas. No floating withdrawal in the case of underground tanks.

Description Combination fitting made of plastic as a withdrawal system with measuring line (not Euroflex 2) and TÜV-tested isolating piece that screws into the tank. G $\frac{3}{8}$ stainless steel threaded female connections for suction and return lines. Universal compression fittings for pipes with 8 and 10 mm outside diameters for connecting the suction line are enclosed. The integrated check valve with elastic valve seat keeps the oil column in the suction line from being interrupted when the burner is off. Quick-action shut-off valve with lever for remote closing in emergency situations. Pressure- and vacuum-tight up to 1 bar. Also available without check valve for self securing withdrawal.

Euroflex 3 with float and special G1 screw connection for withdrawing oil in the clean area (as per TRWS 791 not recommended in underground tanks). Measuring line connection for hose or pipe with 6 mm outside diameter. Suction hose length 2.15 m or 3.15 m with additional float at the suction hose end.

Euroflex 312 (GWG 12 K/1C), combination of level sensor and withdrawal system. With measuring line connection for hose or pipe with 6 mm outside diameter. For battery tanks as per DIN 6620 and tanks as per DIN 6625 manufactured on site. Specially useful if there is no connection socket at the tank. Connection G1 $\frac{1}{2}$.

Technical specifications

Connection

Tank: G1 male thread
(Euroflex 312: G1 $\frac{1}{2}$ male thread)
Suction/return line: G $\frac{3}{8}$ female thread
Measuring line: 6 mm

Length

Suction hose: 2.15 m or 3.15 m
Measuring hose: 2.15 m or 3.15 m
(not Euroflex 2)

Test pressure

Max. 6 bar

Flow rate

Max. 150 l/h

Material

Screw fitting: Plastic (POM), blue
Suction hose: NBR/PVC
Balance chamber: Zamak (ZnAl4Cu1)

Approval

Conformity certificate (EN 12514-2), ÜHP
Euroflex 312: CE marking as per EC Construction Products Regulation 305/2011, EU 574/2014, EN 13616:2004

DG: G, PG: 1			Part no.	Price €
Euroflex 2 (2.15) , suction hose 2.15 m, without measuring line connection	1	25	20162	
Euroflex 3 (2.15) , suction hose 2.15 m	1	25	20160	
Euroflex 3 (3.15) , suction hose 3.15 m	1	25	20164	
Euroflex 3 with float , suction hose 2.15 m	1	25	20130	
Euroflex 3 with float , suction hose 3.15 m	1	20	20131	
Euroflex 3 (3.15) without check valve , suction hose 3.15 m for self-securing suction line	1	25	20129	
Euroflex 312 (GWG 12 K/1C) , suction hose 2.15 m	1	10	20190	
Conversion kit float kit G1 for Euroflex and Miniflex	1	25	20125	
Conversion kit float kit G1$\frac{1}{2}$ for single tanks and communicating withdrawal systems	1	-	20120	
Conversion kit shut-off valve for Euroflex (10/98 and later), Miniflex and communicating AFRISO withdrawal systems for battery tanks for conversion to self-securing suction lines	1	-	74305	



Pull cord for remote closing
See page 131.

Euroflex with heating band, Miniflex



6

Euroflex TH

Application For withdrawal of fuel oil EL or diesel fuel in single-line mode from tanks that may be subjected to temperatures of less than 5 °C (cloud point, paraffin). Suitable for flood hazard areas.

Description Combination fitting Euroflex 2 as a withdrawal system with heating band that screws into the tank. A self-controlling heating band is attached to the suction line; at the bottom of the tank the band forms a spiral around the suction point. The required length depends on the tank type and size as well as the installation site. The self-controlling heating band is designed to avoid overheating and burning out. The band is connected to AC 230 V via a connection cable (2 m) and a residual current device. Adaptation to the tanks with special screw connection to avoid twisting. Watertight up to 10 m water column.

Technical specifications**Connection**

Tank: G1 male thread
Suction line: G $\frac{3}{8}$ female thread

Length

Heating band: 5 m, or 7.5 m
Suction hose: 3.15 m (can be shortened)

Heating capacity

At 10 °C: 25 W/m

Miniflex

For withdrawal of fuel oil from underground and aboveground tanks in single-line or dual-line mode. Suitable for the following media: Fuel oil EL (DIN 51603-1) and diesel fuel (EN 590) as well as biofuel and biodiesel with max. 20 % FAME. Also for use in flood hazard areas.

Combination fitting made of brass as a withdrawal system with measuring line that screws into the tank. Threaded female connection for suction and return lines. Universal compression fittings for pipes with 8 and 10 mm outside diameters for the suction line are enclosed. Measuring line connection for hose or pipe with 6 mm outside diameter. The integrated check valve with elastic valve seat keeps the oil column in the suction line from being interrupted when the burner is off. Quick-action shut-off valve with lever for remote closing in emergency situations. Pressure- and vacuum-tight up to 1 bar.

Connection

Tank: G1 male thread
Suction/return line: G $\frac{3}{8}$ female thread
Measuring line: 6 mm

Length

Suction hose: 2.15 m or 3.15 m
Measuring hose: 2.15 m or 3.15 m (not Miniflex 2)

Test pressure

Max. 6 bar

Flow rate

Max. 150 l/h

Material

Screw fitting: brass
Suction hose: NBR/PVC
Balance chamber: Zamak (ZnAl4Cu1)

DG: G	PG			Part no.	Price €
Euroflex TH , suction hose 3.15 m, 5 m heating band	1	1	-	21010	
Euroflex TH , suction hose 3.15 m, 7.5 m heating band	1	1	-	21011	
Miniflex 2 , suction hose 2.15 m, without measuring line connection	2	1	25	74200	
Miniflex 3 , suction hose 2.15 m	2	1	25	74300	
Miniflex 3 , suction hose 3.15 m	2	1	25	74310	

i

See Euroflex ordering table for conversion kit for Miniflex.

Pull cord, pressure compensation unit

Description **Pull cord** Pull cord with handle and a sealable case for the remote activation of quick-action shut-off valves (e.g. Euroflex or Miniflex). TÜV-tested. Consisting of:

- Pull cord (steel, plastic-coated), 10 m long
- Handle
- 4 eyelet screws for deflecting the pull cord
- Sealable case with wire and lead seal
- Dowels and screws



Pull cord

Application **Pressure compensation unit DAE** Used to limit pressure increases in closed pipe sections resulting from expansion caused by temperature changes. Suitable for fuel oil pipe sections which are closed at both ends (e.g. by means of solenoid valves or check valves) and which are subject to considerable temperature differences (e.g. due to pipe heating). Suitable for use in flood hazard areas.

Description Connection G^{3/8} female thread at both ends. A pipe volume of 725 cm³ can be buffered at a temperature difference of 40 °C. This corresponds to the following max. line lengths (depending on the line diameter):

- 25.5 m ≥ Ø 8 x 1
- 14 m ≥ Ø 10 x 1
- 9 m ≥ Ø 12 x 1

Watertight up to 10 m water column.

Approval

Conformity certificate (ÜHP)

As per EN 12514-2



Pressure compensation unit DAE

DG: G	PG	Part no.	Price €
Pressure compensation unit DAE	2	20800	
Pull cord	1	20475	

Protection equipment against siphoning: anti-siphon valves

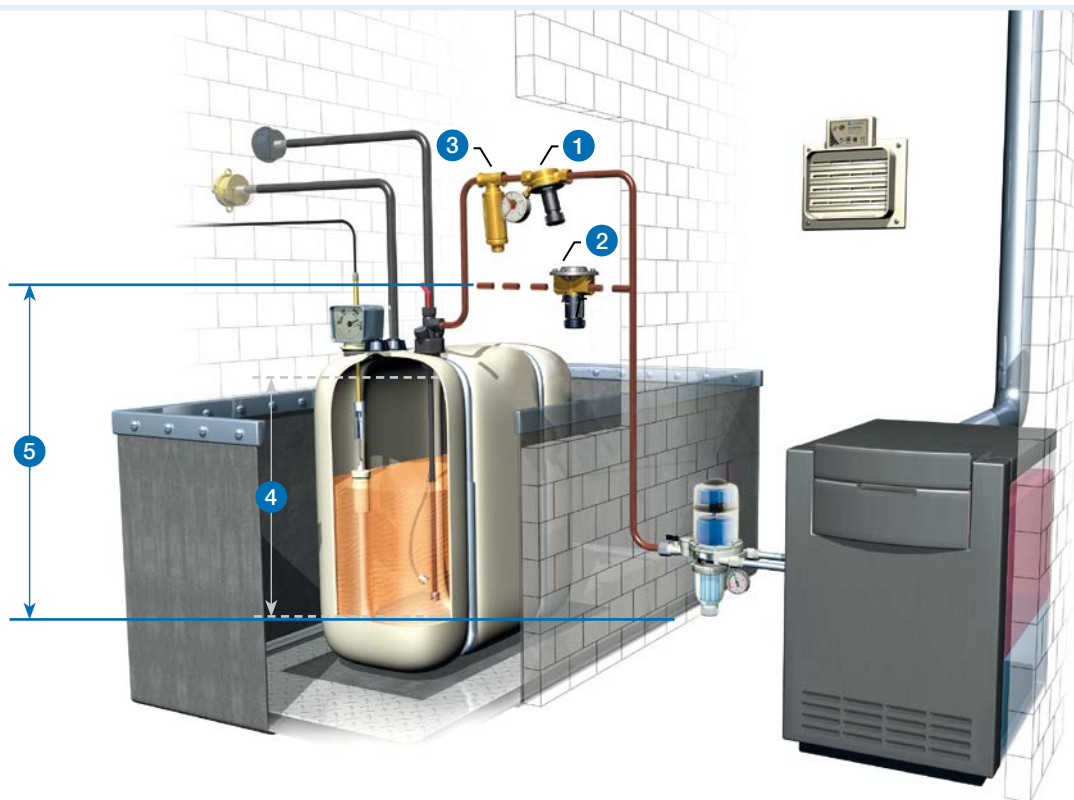

- 1 Piston type anti-siphon valve KAV*
- 2 Diaphragm type anti-siphon valve MAV*
- 3 Pressure compensation unit DAE
- 4 For KAV: Set actual safe height
- 5 For MAV: Set max. height difference between MAV and the lowest line point at the system

* Mounting position (example), arrangement is variable and must be adapted to suit local conditions.

Legal and technical requirements concerning fuel oil consuming systems

Legislation for water pollution control (German Water Act WHG) stipulates that any adverse modification of the characteristics of water must be avoided. For example, § 62 and § 63 of the German Water Act specify the handling of water-polluting substances in facilities.

In the case of oil consuming systems operating in suction mode where a pipe section is below the maximum tank level, fuel oil can be siphoned out if a leak occurs. Therefore, protection equipment against siphoning must be installed. Anti-siphon valves are used for this purpose; they are available as solenoid, diaphragm or piston type anti-siphon valves. Diaphragm or piston type anti-siphon valves are usually installed in smaller and medium sized facilities; the piston type anti-siphon valve offers a number of decisive advantages.

Depending on the applicable regulations, the valves must be approved.

Notes on installation

It must be ensured that the vacuum at the suction end at the oil burner pump does not exceed 0.4 bar.

Factors to be considered include:

- The maximum suction lift at minimum oil level
- The suction line length
- The viscosity of the oil in the storage tank at extreme winter temperatures
- Additional pressure losses caused by fittings (such as oil filters, shut-off valves, etc.) and lines

Piston type anti-siphon valve KAV



Option:
Pressure gauge for
indicating the KAV
opening pressure

- Piston instead of diaphragm – for maximum safety even in case of pollution, ice or system overpressure
- Adjusted value corresponds to the safe height (reduced line resistance)
- Also for outdoor use (manhole)
- Sealed system for error-free operation
- Pressure relief mechanism in both directions

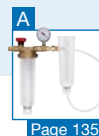

Page 135

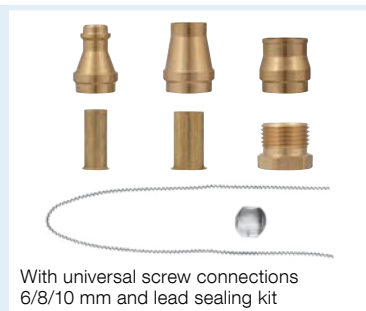

With universal screw connections
6/8/10 mm and lead sealing kit

Application For oil carrying suction lines in oil consuming systems where a pipe section is below the maximum tank level. KAV keeps fuel oil from being siphoned out of the tank in the case of leaks in the suction line. Suitable for the following media: Fuel oil (DIN 51603-1) and diesel fuel (EN 590) as well as biofuel and biodiesel with up to 100 % FAME. Also for use in flood hazard areas.

Description Vacuum-controlled shut-off system with a completely new function principle. KAV is closed when the burner pump is not in operation. When the burner pump starts, a vacuum is generated in the suction line. This opens the KAV and fuel oil is pumped from the tank. If the suction line has a leak or if the burner pump stops, KAV closes and the suction line between the tank and the burner pump is closed. KAV features a pressure relief mechanism, i.e. if the fuel oil contained in the suction pipe heats up and therefore expands, KAV opens. The fuel oil can flow back into the tank, provided that a tank withdrawal fitting without backflow preventer is installed. The pressure relief is independent of the adjusted safe height and operates reliably at a response pressure as low as 300 mbar. KAV is continuously adjustable from 1–4 m. The adjusted value corresponds to the actual safe height and not the installation height (as, for example, in the case of diaphragm type anti-siphon valves). This results in reduced line resistance, which has a positive effect on the service life of the burner and the pump. KAV is designed as a sealed system. Therefore, no vent is required and water or dirt cannot get into the system. Since the sensitive diaphragm as the main actuating element has been replaced by a piston, malfunctions caused by pollution, ice or system overpressure (rupture of the diaphragm) are practically impossible. Watertight up to 10 m water column.

Technical specifications

Adjustment of safe height

Corresponds to actual safe height
1–4 m, continuously adjustable

Connection thread

G $\frac{3}{8}$ female thread at both ends

Mounting position

Any

Oil flow rate

Max. 220 l/h

Operating temperature range

Medium/ambient: -25/+40 °C

Vacuum-tight

Up to -1 bar

Test pressure

Max. 10 bar

Response pressure

Pressure relief: 300 mbar

Housing material

Brass

Approval

DIBt: Z-65.50-415

Scope of delivery

Piston type anti-siphon valve with screw connector kit for pipes \varnothing 6, 8 and 10 mm and lead sealing kit

DG: G, PG: 2			Part no.	Price €
Piston type anti-siphon valve KAV	1	20	20240	
Pressure gauge (-0.7/+0.9 bar) for indicating the KAV opening pressure	1	10	70030	

Diaphragm type anti-siphon valve MAV



- Safe height 1–4 m
- With shut-off and venting function



Page 135

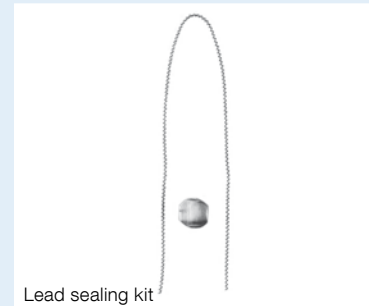

Lead sealing kit

Application

For oil carrying suction lines in oil consuming systems where a pipe section is below the maximum tank level. MAV keeps fuel oil from being siphoned out of the tank in the case of leaks. Suitable for the following media: Fuel oil (DIN 51603-1) and diesel fuel (EN 590) as well as biofuel and biodiesel with max. 20 % FAME. Also for use in flood hazard areas.

Description

MAV is continuously adjustable to a safe height of 1–4 m for optimum adaptation to suit local conditions. The adjusted value corresponds to difference between the installation height and the lowest point of the oil line. MAV shuts off under spring pressure and opens under the vacuum caused by the pump. Watertight up to 10 m water column. If necessary, install a pressure compensation unit.

Technical specifications

Adjustment of safe height

1–4 m (corresponds to installation height), continuously adjustable

Connection thread

G $\frac{3}{8}$ female thread at both ends

Mounting position

Any

Oil flow rate

Max. 220 l/h

Operating temperature range

Medium/ambient: -25/+40 °C

Vacuum-tight

Up to -1 bar

Test pressure

Max. 6 bar

Housing material

Brass

Approval

DIBt: Z-65.50-415

Scope of delivery

Diaphragm type anti-siphon valve with lead sealing kit

DG: G	PG			Part no.	Price €
Diaphragm type anti-siphon valve MAV	2	1	20	20139	
Screw connections with Cu flat gasket G$\frac{3}{8}$ x 6 (dual)	3	1	-	20507	
Screw connections with Cu flat gasket G$\frac{3}{8}$ x 8 (dual)	3	1	-	20504	
Screw connections with Cu flat gasket G$\frac{3}{8}$ x 10 (dual)	3	1	-	20505	
Screw connections with Cu flat gasket G$\frac{3}{8}$ x 12 (dual)	3	1	-	20506	

Tester for safety-related equipment against siphoning



Manufacturer-independent application

- Reliable tests of all diaphragm type/piston type anti-siphon valves
- Simple check and assessment of the system safety
- Test can be performed easily at all systems with standard filter combinations



Application Tester for function tests of built-in mechanical "safety-related equipment against siphoning" (diaphragm type or piston type anti-siphon valves) in oil carrying pipes or withdrawal systems. Test can be performed at all systems with standard filter combinations.

If no AFRISO filter cup with test and drain system is available, it is sufficient to replace the existing filter cup with the filter cup of the tester. AFRISO recommends to replace all filter cups without drain system so that the fuel oil filter can be drained rapidly and the function test performed easily during servicing. Suitable for tests with the following media: Fuel oil EL (DIN 51603-1) and diesel fuel (EN 590) as well as biofuel and biodiesel with up to 100 % FAME.

Description The tester for "safety-related equipment against siphoning" allows to quickly come to a sound conclusion concerning the correct operation of anti-siphon valves. Mounting is simple: Screw the filter cup of the tester into the fuel oil filter of the facility (not necessary in the case of oil filter cups with test and drain system), plug the hose into the tester drain system, connect an oil suction pump to the other end of the tester and you are ready for testing. For the test, a vacuum must be generated which sucks in oil; the oil flows into the tester cup. The vacuum is maintained in the tester cup via the shut-off fitting and displayed by the pressure gauge. When no more oil flows into the tester cup, there is pressure equilibrium. The vacuum can now be read at the test pressure gauge and you can determine whether the siphoning protection works.

Technical specifications

Dimensions (W x H x D)

Tester: 180 x 286 x 71 mm
Case: 395 x 106 x 295 mm

Range

-0.6/0 bar

Connection

G $\frac{3}{8}$ with 60° cones

Operating temperature range

Ambient: -25/+40 °C
Storage: -25/+60 °C

Scope of delivery

- Tester with long filter cup
- Vacuum gauge
- Hose
- Long tester cup with drain system
- Plastic case

6

i

Safety equipment against siphoning must be checked for correct operation at least every 5 years according to the approval.

Inspection certificate
www.afriso.com > INFO
CENTRE > Downloads

DG: G, PG: 1			Part no.	Price €
Tester anti-siphon valve	1	-	20239	
Accessories				
Filter cup short with drain system	1	-	20257	
Filter cup long with drain system	1	-	20262	

Comparison of fuel oil filters

Paper filters

- Optimum ultra-fine filtration
- Specially for small and very small burner capacities
- Preferably for single-line mode



Opticlean MS-5/MC-7 ultra-fine filter

Optimum filter surface due to folded paper filter.

Mesh size

- 20–35 μm (MS-5)
- 5–20 μm (MC-7)

Filter surface: 500 cm^2 (MS-5)
700 cm^2 (MC-7)

Opticlean MC-18 ultra-fine filter

Optimum filter effectiveness and long service life.

Mesh size: 5–20 μm
Filter surface: 1,850 cm^2

Can be used with long filter cup.

Replaceable filter cartridge

Excellent filtration. Also suitable for pressure mode and temperatures of up to 80 °C.

Mesh size: 12–30 μm
Filter surface: 967 cm^2

Can be used for all AFRISO filter types with additional adapter.

6

Sintered plastic sieves

- Excellent filtration
- For small and medium burner capacities
- Suitable for single- and dual-line mode
- Suitable for almost all standard filter combinations



Sintered plastic sieve, short

Star shape for large filter surface.

Colour code: Blue
Mesh size: 50–70 μm
Filter surface: 115 cm^2

Optimum replacement characteristics: Filter base does not swell.

Sintered plastic sieve Optimum

Excellent filtration and long service life.

Colour code: Blue
Mesh size: 50–70 μm
Filter surface: 200 cm^2

Can be used with long filter cup, preferably for single-line mode.

Filter cup Optimum

Extra long filter cup provides for sedimentation volume and space for all standard, long filter inserts.

Version with drain system

- Removing the oil from the oil filter quickly
- No oil odour caused by oil dripping

Felt and Stainless steel sieve

- Proven filtration technology

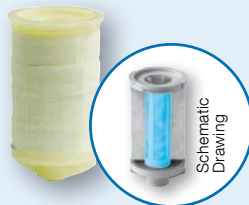

Felt sieve with internal tubular sieve

For medium and high burner capacities. Suitable for single- and dual-line mode.

Mesh size: 50–75 μm
Filter surface: 15.3 cm^2
below the felt rings

Disadvantage: Filter fibres may come loose and get into the burner nozzles.

Stainless steel sieve

Good filtration, pollution visible. For medium and high burner capacities. Suitable for single- and dual-line mode.

Mesh size: 100 μm
Filter surface: 48 cm^2

Single-line/dual-line filters for fuel oil



Dual-line filter Z 500 Si//St/Fi

Application For dual-line systems. Suitable for fuel oil EL (DIN 51603-1) and diesel fuel (EN 590).

Description Brass filter housing, filter cup made of transparent, impact-resistant plastic. With check valve in the return line and shut-off valve in the flow line. Universal compression fittings for pipes with 8/10 mm outside diameters included. Watertight up to 10 m water column.

Approval Conformity certificate (ÜHP) as per EN 12514-2.



Single-line filter R 500 Si/St/Fi

For single-line systems with return supply. Suitable for the following media: Fuel oil EL (DIN 51603-1), diesel fuel (EN 590), biofuel and biodiesel with max. 20 % FAME.

Brass filter housing, filter cup made of transparent, impact-resistant plastic. With shut-off valve in the flow line, vent valve with hose connector in the return line. Universal compression fittings for pipes with 8/10 mm outside diameters included.

Conformity certificate (ÜHP) as per EN 12514-2.



Single-line filter V 500 Si/St

For single-line systems. Suitable for the following media: Fuel oil EL (DIN 51603-1), diesel fuel (EN 590), biofuel and biodiesel with max. 20 % FAME.

Brass filter housing, filter cup made of transparent, impact-resistant plastic. With shut-off valve. Universal compression fittings for pipes with 8/10 mm outside diameters included. Watertight up to 10 m water column.

Conformity certificate (ÜHP) as per EN 12514-2.

6

DG: G, PG: 2	Connection		Universal screw connection	Filter	* Oil throughput $\Delta p=100$ mbar			Part no.	Price €
	Tank	Burner							
Dual-line filter Z 500 Si	2 x G $\frac{3}{8}$ female	2 x G $\frac{3}{8}$ male	2 x 8/10 mm	Sintered plastic	200 l/h	1	25	20429	
Dual-line filter Z 500 Fi	2 x G $\frac{3}{8}$ female	2 x G $\frac{3}{8}$ male	2 x 8/10 mm	Felt	200 l/h	1	25	20428	
Dual-line filter Z 500 St	2 x G $\frac{3}{8}$ female	2 x G $\frac{3}{8}$ male	2 x 8/10 mm	Steel	220 l/h	1	25	20425	
Single-line filter R 500 Si (return)	1 x G $\frac{3}{8}$ female	2 x G $\frac{3}{8}$ male	1 x 8/10 mm	Sintered plastic	210 l/h	1	20	20281	
Single-line filter R 500 Fi (return)	1 x G $\frac{3}{8}$ female	2 x G $\frac{3}{8}$ male	1 x 8/10 mm	Felt	240 l/h	1	20	20282	
Single-line filter R 500 St (return)	1 x G $\frac{3}{8}$ female	2 x G $\frac{3}{8}$ male	1 x 8/10 mm	Steel	250 l/h	1	20	20283	
Single-line filter V 500 Si	1 x G $\frac{3}{8}$ female	1 x G $\frac{3}{8}$ male	1 x 8/10 mm	Sintered plastic	250 l/h	1	25	20292	
Single-line filter V 500 St	1 x G $\frac{3}{8}$ female	1 x G $\frac{3}{8}$ male	1 x 8/10 mm	Steel	320 l/h	1	25	20294	
Dual-line filter Z ½-500 Si	2 x G $\frac{1}{2}$ female	2 x G $\frac{1}{2}$ female	---	Sintered plastic	310 l/h	1	25	20480	
Dual-line filter Z ½-500 St	2 x G $\frac{1}{2}$ female	2 x G $\frac{1}{2}$ female	---	Steel	500 l/h	1	25	20482	
Single-line filter V ½-500 Si	1 x G $\frac{1}{2}$ female	1 x G $\frac{1}{2}$ female	---	Sintered plastic	390 l/h	1	25	20485	
Single-line filter V ½-500 St	1 x G $\frac{1}{2}$ female	1 x G $\frac{1}{2}$ female	---	Steel	560 l/h	1	25	20487	

* At filter insert pollution degree of 50 %.

Automatic fuel oil de-aerator Product highlight: FloCo-Top-2CM



TÜV-tested

Advantages - your benefits

- Reduced height facilitates installation if mounting space is limited
- Vacuum gauge for monitoring the system pressure and indicating when the filter needs to be replaced
- Easy installation with click system and AFRISO universal screw connection or standard screw connection
- Proofed Barrier if installed with vent hose
- Suitable for use in flood hazard areas

6

The oil is de-aerated via the vent hose, the system remains odour-tight. Connection via supply air of the room air-independent ventilation or via the return supply of the tank withdrawal system Euroflex.

Rotatable service indicator for the system owner. It is easy to see when the filter needs to be changed. If the filter insert is polluted, the vacuum increases and the heating expert can be notified.

De-aerator unit with dual float safety system – keeps oil foam from escaping.

Backflow preventer with integrated pressure relief towards the tank.



Pipe connection for universal compression fitting or stand screwed connection with threaded connection G^{3/8}.

Lateral dual shut-off valve, can be operated from both sides for left or right mounting.

Drain valve with hose connection for fast, clean draining of the oil from the filter cup during filter replacement, emergency operation or connection of a tester for tightness tests.

Robust base housing made of high-strength plastic.

Installation with click system.

Drain system for controlled discharging of the oil from the vent unit.

Optimised filter cup with thread and radial O ring seal for easy loosening of screwed connection.



Automatic fuel oil de-aerator comparison



	Automatic fuel oil de-aerators		Automatic fuel oil de-aerators with filter				
Version	Flow-Control 3/K	Flow-Control 3/K HT	FloCo-Top-1K	FloCo-Top-1C	FloCo-Top-2 KM Si	FloCo-Top-2 Optimum MC-18	FloCo-Top-2CM
Catalogue page	See page 140	See page 141	See page 142	See page 143	See page 144	See page 144	See page 146
Application area	Single-line systems with return line						
Media	<ul style="list-style-type: none"> Fuel oil EL Diesel fuel Biofuel or biodiesel with up to 20 % FAME 	<ul style="list-style-type: none"> Fuel oil EL Diesel fuel Biofuel or biodiesel with up to 100 % FAME Vegetable oils (colza oil) 	<ul style="list-style-type: none"> Fuel oil EL Diesel fuel Biofuel or biodiesel with up to 20 % FAME 				
Function	Continuous de-aeration		Continuous de-aeration and oil filtration		Continuous de-aeration and multiple oil filtration		Continuous de-aeration and oil filtration
Filter	-	-	Sintered plastic filter		Sintered plastic filter	Opticlean ultra-fine filters	Sintered plastic or Opticlean filter
Vacuum gauge	-	-	-	-	-0.7/+0.9 bar		
Approval	Conformity certificate (ÜHP) as per EN 12514-2						

6

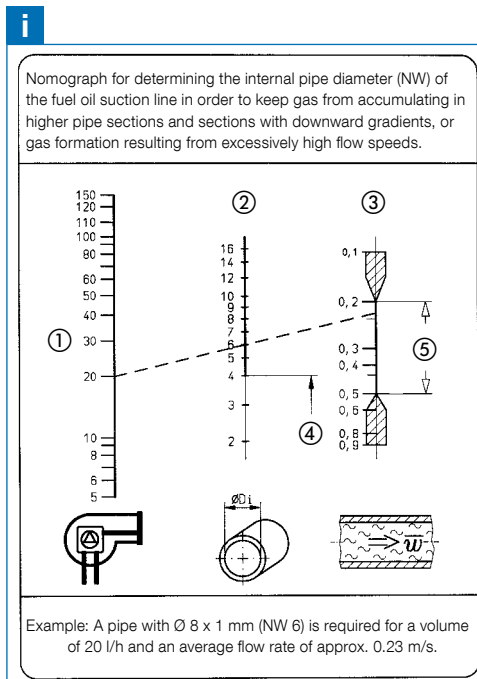

Our tip

Only installation by expert companies certified according to the applicable regulations ensures optimum operation of the automatic de-aerators. For optimum combustion, longer nozzle and filter service life and reliable function, the expert determines the following prior to installation and compares the values with the nomograph:

- Oil throughput per hour at burner nozzle
- Inside diameter of the (installed) oil suction line
- Vacuum (overpressure) in the oil carrying pipe upstream of the burner

The oil suction line is often too large. The flow rates of 0.2/0.5 m/s, required according to DIN 4755-2, are often not reached in systems converted from dual-line to single-line mode. The nomograph shows the proper values for sizing the suction line.

- ① Nozzle consumption l/h
- ② Inside diameter of the suction line in mm
- ③ Flow rate of the fuel oil in m/s
- ④ Less than $\text{Ø} 4$ "not advisable"
- ⑤ Recommended range as per DIN 4755-T2

Automatic fuel oil de-aerator Flow-Control 3/K TÜV-tested



- Trouble-free operation due to automatic de-aeration
- Dual float safety system keeps oil foam from escaping
- Increased fuel oil filter service life – the amount of oil drawn from the tank corresponds exactly to the oil actually burnt
- The suction line can usually have a smaller cross section



Application

For single-line systems with return line in oil-fired systems for continuous de-aeration. Suitable for the following media: Fuel oil EL (DIN 51603-1) and diesel fuel (EN 590) as well as biofuel and biodiesel with max. 20 % FAME. Also for use in flood hazard areas. The risk of a leak in the return line going unnoticed is removed with Flow-Control. It is no longer necessary to regularly check the return line for leaks.

Description

Automatic fuel oil de-aerator consisting of a diecast zinc housing with female G $\frac{1}{4}$ connection thread at the tank end and male G $\frac{3}{8}$ connection threads with 60° cone at the burner end for connection of the burner hoses. Plastic or metal de-aerator hood. Flow-Control 3/K features two separate float chambers. The lower float chamber contains the operating float; the upper float chamber contains the safety float. The upper float chamber keeps oil foam from escaping via the vent opening (e.g. during commissioning/filter exchange) and indicates malfunctions of the vent valve. An oil hose with ball-shaped sealing for 60° cone and a G $\frac{3}{8}$ union nut is supplied for connection to the fuel oil filter. Watertight up to 10 m water column. All Flow-Control versions are TÜV-tested.

Flow-Control 3/K (G $\frac{1}{4}$) with connections G $\frac{1}{4}$ female at burner end instead of G $\frac{3}{8}$ male thread.

Technical specifications

Connection burner

G $\frac{3}{8}$ male with 60° cone for burner hose or G $\frac{1}{4}$ female (part no. 69978)

Connection tank

Part no. 69930:
G $\frac{3}{8}$ female with oil hose G $\frac{1}{4}$ male x G $\frac{3}{8}$ female;
Part no 69978:
G $\frac{1}{4}$ female thread with oil hole G $\frac{1}{4}$ male thread x G $\frac{3}{8}$ union nut for connection to filter

Nozzle capacity

Max. 100 l/h

Return flow

Max. 120 l/h

Separating capacity air/gas

Approx. 4 l/h

Mounting position

Float housing vertical to the top

Operating temperature range

Medium: Max. 60 °C
Ambient: Max. 60 °C

Operating overpressure

Max. 0.7 bar
(corresponds to static oil column of approx. 8 m)

Test pressure

6 bar

Dimensions

W x H x D: 95 x 147 x 95 mm

Tests

TÜV-tested (S 133 2013 E2)

Approval

Conformity certificate (ÜHP) as per EN 12514-2

i

The devices must not be subjected to undiluted additives, alcohol and acids.

DG: G, PG: 1			Part no.	Price €
Flow-Control 3/K (G$\frac{3}{8}$ male)	1	-	69930	
Flow-Control 3/K (G$\frac{1}{4}$ female)	1	-	69978	

Automatic fuel oil de-aerator

Flow-Control 3/K HT TÜV-tested



- **High temperature version:**
Up to a temperature of the medium of 80 °C
- **Dual float safety system keeps oil foam from escaping**
- **Increased fuel oil filter service life – the amount of filtered oil drawn from the tank corresponds exactly to the oil burnt**
- **No unnoticed leakage in the return line**



Application For single-line systems with return line in oil-fired systems for continuous de-aeration. Suitable for the following media: Fuel oil EL (DIN 51603-1) and diesel fuel (EN 590) as well as biofuel and biodiesel with up to 100 % FAME as well as vegetable oils (colza oil). Also for use in flood hazard areas. Flow Control 3/K HT is recommended for mounting below the max. fuel oil level in the tank and for any application requiring particular safety.

Description Automatic fuel oil de-aerator consisting of a diecast zinc housing with female G $\frac{1}{4}$ connection thread at the tank end and male G $\frac{3}{8}$ connection threads with 60° cone at the burner end for connection of the burner hoses. An oil hose with ball-shaped sealing for 60° cone and a G $\frac{3}{8}$ union nut is supplied for connection to the fuel oil filter. The de-aerator hood consists of glass-fibre reinforced plastic (not transparent), all seals are made of FKM. Flow-Control 3/K HT features 2 separate float chambers. The lower float chamber contains the operating float; the upper float chamber contains the safety float. The upper float chamber keeps oil foam from escaping via the vent opening (e.g. during commissioning/filter exchange) and also indicates malfunctions of the vent valve. The risk of a leak in the return line going unnoticed is removed with the single-line system. It is no longer necessary to regularly check the return line. Also suitable for pressure mode up to 0.7 bar. Watertight up to 10 m water column.

Technical specifications

Connection burner

G $\frac{3}{8}$ male with 60° cone for burner hose

Connection tank

G $\frac{1}{4}$ female or oil hose G $\frac{1}{4}$ male x G $\frac{3}{8}$ union nut for connection to filter

Nozzle capacity

Max. 100 l/h

Return flow

Max. 120 l/h

Separating capacity air/gas

Approx. 4 l/h

Mounting position

Float housing vertical to the top

Seals

FKM

Operating temperature range

Medium: Max. 80 °C

Ambient: Max. 60 °C

Operating overpressure

Max. 0.7 bar

(corresponds to static oil column of approx. 8 m)

Test pressure

6 bar

Dimensions

W x H x D: 95 x 147 x 95 mm

Tests

TÜV-tested (S 133 2013 E2)

Approval

Conformity certificate (ÜHP)
as per EN 12514-2

i

The devices must not be subjected to undiluted additives, alcohol and acids.

DG: G, PG: 1			Part no.	Price €
Flow-Control 3/K HT	1	-	69929	

Automatic fuel oil de-aerator

FloCo-Top-1K TÜV-tested

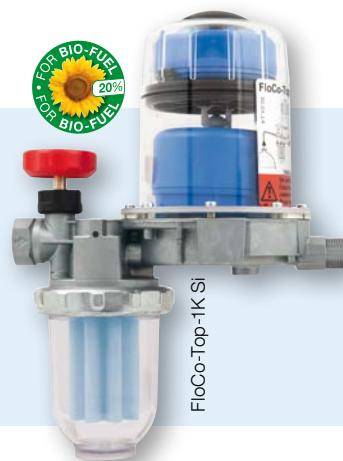

FloCo-Top-1K Si

- Fuel oil de-aerator, filter and shut-off valve in a single, compact unit
- Safety system keeps oil foam from escaping



Page 148



Page 147

Application For single-line systems with return line in oil-fired systems for continuous de-aeration. Suitable for the following media: Fuel oil EL (DIN 51603-1) and diesel fuel (EN 590) as well as biofuel and biodiesel with max. 20 % FAME. Also for use in flood hazard areas.

Description Automatic fuel oil de-aerator, safety version, with integrated filter and shut-off valve. Zinc die cast housing with G $\frac{3}{8}$ female connection thread at the tank end and G $\frac{3}{8}$ male connection threads at the burner end with female cone for connection of the burner hoses. The de-aerator hood is made of transparent plastic and features two separate float chambers. The lower float chamber contains the operating float; the upper float chamber contains the safety float. The upper float chamber keeps oil foam from escaping through the vent opening. In addition, it is possible to detect malfunctions in the de-aeration system. Watertight up to 10 m water column.

Technical specifications

Connection burner
G $\frac{3}{8}$ male with 60° cone for burner hoses

Connection tank
G $\frac{3}{8}$ female

Nozzle capacity
Max. 100 l/h

Return flow
Max. 120 l/h

Separating capacity air/gas
Approx. 4 l/h

Mounting position
Float housing vertical to the top

Operating temperature range
Medium: Max. 60 °C
Ambient: Max. 60 °C

Operating overpressure
Max. 0.7 bar
(corresponds to static oil column of approx. 8 m)

Test pressure
6 bar

Dimensions
W x H x D: 165 x 221 x 99 mm

Material
Housing: Zinc die cast
De-aerator hood: Transparent plastic
Filter cup: Transparent plastic

Tests
TÜV-tested (S 133 2013 E2)

Approval
Conformity certificate (ÜHP)
as per EN 12514-2

Scope of delivery

- Fuel oil de-aerators
- Bracket with mounting material
- Cover for connection of the vent hose

DG: G, PG: 1	De-aerator hood	Filter	Filter cup	Part no.	Price €
FloCo-Top-1K Si	Plastic	Sintered plastic sieve short, 50 µm	Short	69960	
Spare part					
Bracket FloCo-Top-1	-	-	-	69946	

Automatic fuel oil de-aerator

FloCo-Top-1C TÜV-tested

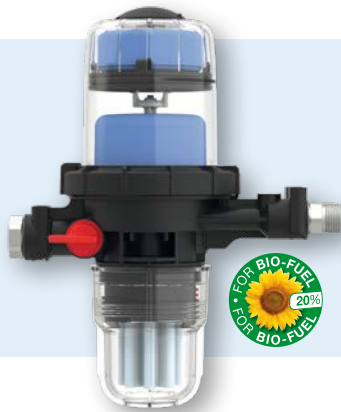

- Fuel oil de-aerator, filter and shut-off valve in a single, compact unit
- Backflow preventer with integrated pressure relief towards the tank
- Safety system keeps oil foam from escaping
- Drain system for controlled discharging of the oil from the vent unit



Application For single-line systems with return line in oil-fired systems for continuous de-aeration. Suitable for the following media: Fuel oil EL (DIN 51603-1) and diesel fuel (EN 590) as well as biofuel and biodiesel with max. 20 % FAME. Also for use in flood hazard areas.

Description Automatic fuel oil de-aerator, safety version, with integrated filter and lateral dual shut-off valve, can be operated from both sides. Housing made of high-strength plastic with backflow preventer and integrated pressure relief towards the tank. Female connection thread G $\frac{3}{8}$ and male connection thread G $\frac{3}{8}$ with female cone for connection of the burner hoses. The de-aerator hood is made of transparent plastic and features two separate float chambers. The lower float chamber contains the operating float; the upper float chamber contains the safety float. The upper float chamber keeps oil foam from escaping through the vent opening. In addition, it is possible to detect malfunctions in the de-aeration system. Watertight up to 10 m water column.

Technical specifications

Connection burner

G $\frac{3}{8}$ male with 60° cone for burner hoses

Connection tank

G $\frac{3}{8}$ female

Nozzle capacity

Max. 100 l/h

Return flow

Max. 120 l/h

Separating capacity air/gas

Approx. 4 l/h

Mounting position

Float housing vertical to the top

Operating temperature range

Medium: Max. 60 °C

Ambient: Max. 60 °C

Operating overpressure

Max. 0.7 bar

(corresponds to static oil column of approx. 8 m)

Test pressure

6 bar

Dimensions

W x H x D: 185 x 224 x 109 mm

Material

Housing: Plastic

De-aerator hood: Transparent plastic

Filter cup: Transparent plastic

Tests

TÜV-tested

Approval

Conformity certificate (ÜHP)

as per EN 12514-2

Scope of delivery

- Fuel oil de-aerators
- Bracket with mounting material
- Cover for connection of the vent hose

DG: G, PG: 1	De-aerator hood	Filter	Filter cup	Part no.	Price €
FloCo-Top-1C Si	Plastic	Sintered plastic sieve short, 50 µm	Short	70155	
Spare parts					
Bracket FloCo-Top-2/-1C/-2C			-	70127	
Filter cup FloCo-Top-1C/-2C			Short	20277	

Automatic fuel oil de-aerator

FloCo-Top-2 TÜV-tested



FloCo-Top-2KM Si

- Multiple filtration for maximum separation of dirt particles
- Backflow preventer with integrated pressure relief towards the tank
- Drain valve for fast and clean filter change
- Bypass valve for easy and clean burner hose replacement



Application For single-line systems with return line in oil-fired systems for continuous de-aeration. Suitable for the following media: Fuel oil EL (DIN 51603-1) and diesel fuel (EN 590) as well as biofuel and biodiesel (EN 14214) with max. 20 % FAME. Also for use in flood hazard areas. FloCo-TOP-2 can be installed in any system. Multiple filtration is recommended for burners with an oil consumption of < 20 l/h while larger systems should be operated with single filtration.

Description Automatic fuel oil de-aerator, safety version, with integrated filter, shut-off valve and vacuum gauge. Housing with changeover valve for multiple filtration as well as backflow preventer with integrated pressure relief towards the tank. Compact de-aerator hood made of transparent plastic with dual float safety system to keep oil foam from escaping via the de-aerator opening. The vent hose is connected at the side in an unobtrusive way. For venting, the oil is guided via the float chamber and can then be added directly to the flow or it can be filtered again by switching a valve. In the case of multiple filtration, the return oil increases the flow rate so that the filter bowl is permanently filled with de-aerated oil. In service mode, the vacuum gauge indicates the pump vacuum. The shut-off valve can be closed to check the suction capacity of the burner pump. Increased vacuum provides information on the degree of pollution of the filter. The drain valve ensures that replacing the filter is easy and clean: Connect the hose, open the drain valve, loosen the union nut of the filter cup and drain the oil in a controlled way. When the burner hose needs to be replaced, it is sufficient to open a bypass valve so that the oil is drained from the float chamber via the filter cup and the drain system. Watertight up to 10 m water column.

Technical specifications

Connections burner
G $\frac{3}{8}$ male with 60° cone for burner hoses

Tank connection
G $\frac{3}{8}$ female

Nozzle capacity
Max. 100 l/h

Return flow
Max. 120 l/h

Separating capacity air/gas
> 4 l/h

Mounting position
Float housing vertical to the top

Operating temperature range
Medium/ambient: Max. 60 °C

Operating overpressure
Max. 0.7 bar
(corresponds to static oil column of approx. 8 m)

Test pressure
6 bar

Vacuum gauge
Range: -0.7/+0.9 bar

Dimensions (W x H x D)

Short cup: 183 x 254 x 103 mm
Long cup: 183 x 348 x 103 mm

Material

Housing: Zinc die cast
De-aerator hood: Transparent plastic
Filter cup: Transparent plastic

Tests

TÜV-tested (S 133 2013 E2)

Approval

Conformity certificate (ÜHP)
as per EN 12514-2

Scope of delivery

- Fuel oil de-aerators
- Universal screw connections for pipes Ø 6/8/10 mm
- Bracket with mounting material
- Cover for connection of the vent hose
- Drain hose

Automatic fuel oil de-aerator

FloCo-Top-2 TÜV-tested



DG: G, PG: 1		Filter	Filter surface			Part no.	Price €
	FloCo-Top-2KM Si	Sintered plastic sieve short, 50 µm	115 cm ²	1	-	70110	
	FloCo-Top-2KM MS-5	Opticlean MS-5 short, 20–35 µm	500 cm ²	1	-	70134	
	FloCo-Top-2KM Optimum Si	Sintered plastic sieve Optimum, 50 µm	200 cm ²	1	-	70115	
	FloCo-Top-2KM MC-7	Opticlean MC-7 short, 5–20 µm	700 cm ²	1	-	70112	
	FloCo-Top-2KM Optimum MC-18	Opticlean MC-18 long, 5–20 µm	1,850 cm ²	1	-	70114	
Spare parts			PG				
	Vacuum gauge	-0.7/+0.9 bar	2	1	10	70030	
	Bracket for FloCo-Top-2/-1C/-2C	-	1	1	-	70127	

Automatic fuel oil de-aerator

FloCo-Top-2CM TÜV-tested



- Backflow preventer with integrated pressure relief towards the tank
- Drain system and drain valve for fast and clean filter change
- Pressure gauge as service indicator (system pressure / filter change)



Application For single-line systems with return line in oil-fired systems for continuous de-aeration. Suitable for the following media: Fuel oil EL (DIN 51603-1) and diesel fuel (EN 590) as well as biofuel and biodiesel (EN 14214) with max. 20 % FAME. Also for use in flood hazard areas.

Description Automatic fuel oil de-aerator, safety version, with integrated filter, lateral dual shut-off valve (can be operated from both sides) and vacuum gauge. Housing made of high-strength plastic with backflow preventer and integrated pressure relief towards the tank. Compact de-aerator hood made of transparent plastic with dual float safety system to keep oil foam from escaping via the de-aerator opening. For venting, the oil is guided via the float chamber and can then be added directly to the flow. In service mode, the vacuum gauge indicates the pump vacuum. The shut-off valve can be closed to check the suction capacity of the burner pump. Increased vacuum provides information on the degree of pollution of the filter. The drain system and the drain valve ensure that replacing the filter and burner hoses is easy and clean: Connect the hose, open the drain valve and drain the oil in a controlled way. Watertight up to 10 m water column.

Technical specifications

Connections burner
G $\frac{3}{8}$ male with 60° cone for burner hoses

Connection tank
G $\frac{3}{8}$ female

Nozzle capacity
Max. 100 l/h

Return flow
Max. 120 l/h

Separating capacity air/gas
> 4 l/h

Mounting position
Float housing vertical to the top

Operating temperature range
Medium/ambient: Max. 60 °C

Operating overpressure
Max. 0.7 bar
(corresponds to static oil column of approx. 8 m)

Test pressure
6 bar

Vacuum gauge

Range: -0.7/+0.9 bar

Dimensions (W x H x D)

Short cup: 185 x 253 x 109 mm

Long cup: 185 x 341 x 109 mm

Material

Housing: Plastic

De-aerator hood: Transparent plastic

Filter cup: Transparent plastic

Tests

TÜV-tested

Approval

















Conformity certificate (ÜHP) as per EN 12514-2

Scope of delivery

- Fuel oil de-aerators
- Universal screw connections for pipes Ø 6/8/10 mm
- Bracket with mounting material
- Cover for connection of the vent hose
- Drain hose

DG: G, PG: 1	Filter	Filter cup	Part no.	Price €
FloCo-Top-2CM Si	Sintered plastic sieve short, 50 µm	Short	70156	
FloCo-Top-2CM Optimum MC-18	Opticlean MC-18 long, 5–20 µm	Long	70158	
FloCo-Top-2CM MS-5	MS-5 short, 20–35 µm	Short	70159	
Spare parts				
Vacuum gauge, -0.7/+0.9 bar		-	70030	
Bracket FloCo-Top-2/-1C/-2C		-	70127	
Filter cup Optimum with drain valve FloCo-Top-1C/-2C		Short	20288	
Filter cup Optimum with drain valve FloCo-Top-1C/-2C		Long	20289	

Spare parts for filters

DG: G	Description	PG			Part no.	Price €
	Opticlean MC-7* Ultra-fine filter 5–20 µm, short, filter surface: 700 cm ²	1	1	240	20319	
	Opticlean MC-18* Ultra-fine filter 5–20 µm, long, filter surface: 1,850 cm ²	1	1	120	20318	
	Opticlean MS-5* Ultra-fine filter 20–35 µm, short, filter surface: 500 cm ²	1	-	25	20308	
	Replaceable filter cartridge Mesh size: 12–30 µm, filter surface: 967 cm ²	3	1	-	70010	
	Adapter replaceable filter cartridge to AFRISO oil filter and FloCo-Top-1K/-2KM	1	1	-	70020	
	Sintered plastic sieve short, 50–70 µm blue Filter base ABS white Box of 25 pieces	1	-	25	20045	
	Sintered plastic sieve Optimum, 50–70 µm blue Filter base ABS white	1	-	10	20053	
	Felt sieve individually packed in bag that can be closed, in box of 25 pieces	1	-	25	20034	
	Stainless steel sieve 100 µm Box of 250 pieces	1	1	250	20032	
	Filter cup Plastic, for suction mode for oil filter and FloCo- Top-1K/-2KM	Short	1	1	10	20254
		Short with drain valve and transparent drain hose Ø 6 x 500 mm	1	1	-	20257
	Filter cup Plastic, for suction mode for oil filter and FloCo- Top-1K/-2KM	Optimum	1	1	10	20258
		Optimum with drain valve and transparent drain hose Ø 6 x 500 mm	1	1	-	20262
	Filter cup, brass for pressure mode, without union nut. For oil filter and FloCo-Top-1K/-2KM	1	1	-	20261	
	Filter cup FloCo-Top-1C/-2C				20277	
	Filter cup with drain valve FloCo-Top-1C/-2C				20288	
	Filter cup Optimum with drain valve FloCo-Top-1C/-2C				20289	
	O ring for filter cup. For oil filter and FloCo-Top-1K/-2KM	1	-	10	20422	
	Service box Optimum in cardboard box, 4 x O rings (part no. 20422), 4 x sintered plastic sieve (part no. 20053) and 4 x filter cup Optimum standard (part no 20258)	1	1	-	20260	

i

* The filter surface of **Opticlean ultra-fine filters** is up to 37 times greater than that of conventional filter inserts; they excel with an extremely high degree of filtration. Filter fineness of nominal 5 µm (absolute 20 µm) separation is possible.

Even the smallest drops of water and emulsion are retained with high reliability. Opticlean filter cartridges can be used in any standard fuel oil filter, they are metal-free and can be recycled in an environmentally protective way.

Accessories for fuel oil de-aerators/oil filters

Screw connections

Description For installation in the oil pipe. See ordering table for versions.

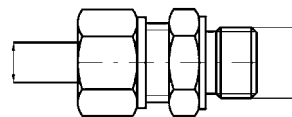

Screw connection

Vacuum gauge

Description For indication of the filter condition. Available for direct mounting to standard fuel oil filters. G $\frac{3}{8}$ union nut at filter end, G $\frac{3}{8}$ male thread with sealing cone 60° at burner end for burner hose. Or with G $\frac{3}{8}$ female thread x G $\frac{3}{8}$ male thread for mounting to filter with G $\frac{3}{8}$ female thread at tank end. Suitable for use in flood hazard areas. Watertight up to 10 m water column.



Vacuum gauge

Replaceable filter adapter

Description The replaceable fine filter cartridge can be fitted to all AFRISO filter types (except Z $\frac{1}{2}$ -500 and V $\frac{1}{2}$ -500) by means of an adapter and can then be operated both in pressure and suction mode.



Replaceable filter adapter

Oil filter spanner

Description To loosen the union nut of the filter cup and the replacement system fine filter cartridge of automatic fuel oil de-aerators and fuel oil filters.

Open end spanner

Description For easy and fast operation of the replaceable filter adapter.



Oil filter spanner



Open end spanner

Hand-held suction pump for fuel oil

Description For commissioning and after faults in the suction line system. With check valve/vent valve.



Hand-held suction pump for fuel oil

DG: G	PG			Part no.	Price €
Screw connection G $\frac{3}{8}$ x 6 mm	3	1	-	20509	
Screw connection G $\frac{3}{8}$ x 8 mm	3	1	-	20508	
Screw connection G $\frac{3}{8}$ x 10 mm	3	1	-	20510	
Screw connection G $\frac{3}{8}$ x 12 mm	3	1	-	20512	
Vacuum gauge G $\frac{3}{8}$ with 60° cone, -0.7/+0.9 bar	2	1	-	20400	
Hand-held suction pump for fuel oil, with hose	1	1	-	70058	
Replaceable filter adapter	2	1	10	70020	
Open end spanner for replaceable filter adapter	3	1	-	70065	
Oil filter spanner	1	1	25	70060	



Pump assemblies for heating and solar thermal systems



Boiler safety group assemblies

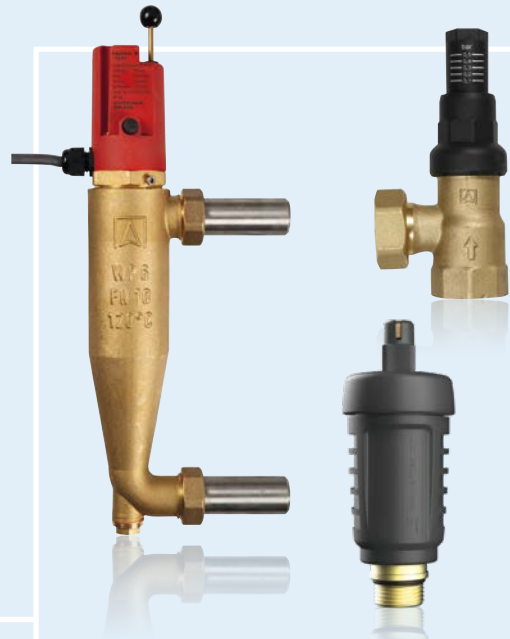

Safety equipment for heating systems



Motorised boiler room vent

CHAPTER 7

Equipment for heating systems, boiler rooms and chimneys

OVERVIEW

Equipment for safe operation of heating systems	152
-------------------------------------------------	-----

SUPPLY AND EXHAUST AIR

Motorised boiler room vent Air-Control	154
Draft stabiliser WZB-1	155

SAFETY EQUIPMENT

Boiler water low level alarm WMS-WP6	156
Thermal safety valve TAS 03	157
Combustion controller FR 1	157
Quick air vent PrimoVent	158
Boiler safety group assemblies KSG	161
Connection assembly for expansion vessels GAK	163
Air separators	165
Sludge separators	166
Flow filters, combined air/flow filters	167
Anti-tamper cap valves	168
Diaphragm safety valves MS , MSM	169
Differential pressure bypass valve DÜ	170
Boiler filling and drain valves KFE, filling fittings FA , FAM	171

FLOW MEASUREMENT

Flow meters DFM 10-1M , 15-2M , 20-2M	172
---------------------------------------------------------------------------------------	-----

HEATING PUMP ASSEMBLIES

3-/4-way mixing valves ARV ProClick	175
Actuators ARM ProClick	178
Boiler manifolds KSV 125/125 HW	180
Heating pump assemblies PrimoTherm® overview	181
Pump assembly PrimoTherm® 180-1/-2 DN 25 KVS Vario	184
Pump assembly PrimoTherm® 180-3 DN 25 RTA for increased return temperature	188
Charging unit RTA 60 DN 25	190
Pump assembly PrimoTherm® 180-1/-2 DN 32 KVS Vario	192

SOLAR THERMAL EQUIPMENT

Solar pump assemblies PrimoSol® 130	197
Filling and flushing unit, diaphragm safety valve MSS , connection kit	199
Quick air vents for solar systems, air separators	200
Collector tank for solar liquid	201

Equipment for safe operation of heating systems

AFRISO offers a broad range of products for the safe operation of heating systems. Irrespective of whether the heating system uses renewable energy or fossil fuels.

Anti-siphon valves, withdrawal systems, level sensors, leak detectors and overflow prevention systems increase the safety of fuel oil storage facilities. Boiler safety group assemblies, solar and heating pump assemblies, connection assemblies for expansion vessels, anti-tamper cap valves, boiler safety group assemblies, diaphragm safety valves, control thermostats, thermal safety valves and boiler water low level alarms are provided as equipment for heating systems.

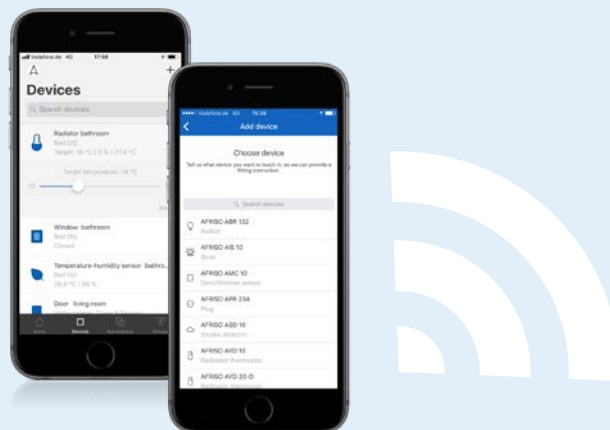

enocean®

The EnOcean® wireless technology allows you to easily integrate alarm units and sensors into building automation systems and operate them conveniently via smartphones or tablets.

AFRISO products in a heating system with oil burner and solar thermal system

- 1 Motorised boiler room vent **Air-Control**
- 2 Radio-controlled water valve **WaterControl 01.1**
- 3 Wireless conductivity water sensor **WaterSensor BWS**
- 4 Water filter **WAF 04-R**
- 5 Boiler safety group assembly **BFK 12**
- 6 Solar pump assembly **PrimoSol® 130-4**
- 7 Collector tank for solar liquid
- 8 Heating pump assembly **PrimoTherm®**
- 9 Boiler water low level alarm **WMS-WP6**
- 10 Boiler safety group assembly **KSG**
- 11 Sludge separator
- 12 Air separator
- 13 Connection assembly for expansion vessels **GAK**
- 14 Automatic fuel oil de-aerator **FloCo-Top-2**
- 15 Piston type anti-siphon valve **KAV**
- 16 Tank contents gauge **MT-Profil**
- 17 Level sensor **GWG** with metallised sleeve
- 18 Withdrawal system **Euroflex**
- 19 Vent cap
- 20 Level sensor filler cap and GWG level sensor fitting for wall mounting type 905
- 21 Oil/water alarm unit **OM 5**
- 22 Digital tank contents indicator **DTA 20 E** (wireless)
- 23 Pneumatic level indicator for water
- 24 Pull cord



7

Oil tank conversion kits

- 25 Calmed inlet
- 26 Manhole cover
- 27 Cartridge filter
- 28 Combination block for compact radiator with valve **VarioQ Kombi**
- 29 Thermostat control head **323**
- 30 Door/window contact **AMC 20**
- 31 Indoor siren **AIS 10**
- 32 Single room temperature controller **CosiTherm® wireless**
- 33 Stainless steel heating circuit manifold **ProCalida® VA 1C Vario-DP** with dynamic control valve
- 34 Room air monitoring: **CO₂ sensor F**
- 35 Battery-less wireless water alarm unit **WaterSensor eco**
- 36 Wireless room temperature sensor **FT**
- 37 Wireless rocker **FT4F-rw**
- 38 AFRISOhome gateway
- 39 Wireless heat detector **AHD 10**
- 40 Thermostat combination block **Vario THK**
- 41 Wireless smoke alarm **ASD 10**
- 42 Air separator combination **Solar LKS**

Motorised boiler room vent Air-Control



- Saves heating costs, is reliable and silent
- System or room cannot cool down
- Sturdy, impact-resistant plastic
- Complete with accessories for easy installation

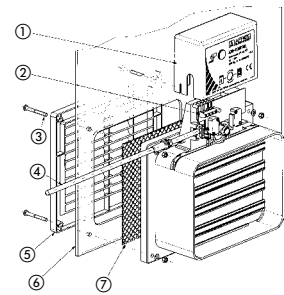

- | | |
|-----------------------------|------------------------------------------|
| ① Hood PC | ⑥ Window/wall (on site) |
| ② Terminal block | ⑦ Insect protection stainless steel mesh |
| ③ Fixing screw | |
| ④ Connection cable (4-core) | |
| ⑤ Protective grille | |

Application Suitable for installation in basement windows or ventilation ducts for burner-controlled oxygen supply of boiler rooms with oil and gas-fired burners of up to 50 kW. System or room cannot cool down.

Description Burner-controlled motorised boiler room vent, consisting of a robust, impact-resistant plastic housing with injection-moulded mounting flange, a mating flange with a protective grille and a gear motor for actuating the slide. Can also be operated manually; with function indication. Boiler rooms which are equipped with oil- or gas-fired burners must be supplied with a sufficient amount of oxygen (e.g. in accordance with the German FeuVo). This is often achieved by constantly open boiler room windows or by inlet air ducts. The cold air which constantly flows into the boiler room causes the boiler and the water supply as well as the pipes to cool down. As a result, the burner is switched on more frequently and consumes unnecessarily high amounts of fuel. Air-Control is mounted onto the pane and is electrically connected to the boiler thermostat. Air-Control can also be mounted onto air ducts. The window remains closed and keeps the warmth inside. As soon as the boiler temperature drops, the boiler thermostat switches on Air-Control. Opening the vent activates a microswitch which closes the burner circuit. The burner starts to operate only when the motorised boiler room vent is open and is supplied with pre-warmed ambient air in the ignition phase. The motorised boiler room vent remains open during the entire combustion process and provides the boiler room with enough fresh air. The burner switches off when the preset temperature is reached. Air-Control closes automatically.

Technical specifications

Housing

Plastic (ABS)
W x H x D: 260 x 300 x 115 mm
Weight: 1.0 kg
Degree of protection: IP 20 (EN 60529)

Installation opening

216 x 166 mm

Cross section fresh air supply

150 cm²

Supply voltage

AC 230 V

Contact rating

AC 250 V, 2 A

Burner capacity

Max. 50 kW. For larger installations, several motorised boiler room vents can be installed.

DG: G, PG: 1	Part no.	Price €
Air-Control	69964	

Draft stabiliser WZB-1



- Saves heating costs, optimises combustion and keeps the chimney draft constant
- Stabilises the chimney draft
- For oil, gas or solid fuel systems

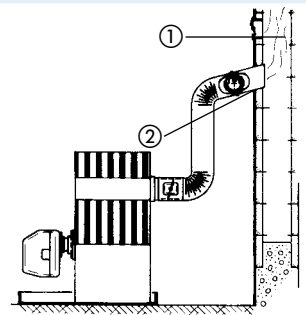

- ① "Chimney connection" always above flue connection
 ② "Flue gas connection" with pipe connection piece

Application

The draft stabiliser for oil, gas or solid fuel systems keeps chimney draft constant and the chimney dry. Suitable for connection to flue gas pipes with \varnothing 120 to 200 mm by means of pipe connection pieces or to brickwork chimneys or chimneys with several walls by means of special connection pieces.

Description

Draft stabiliser made of galvanised sheet steel with flap. The flap is set on site by means of a rotary knob acting on a weight for precise adjustment. Depending on the adjustment of the weight, the flap admits more or less secondary air into the chimney when the vacuum gets too high.

The natural chimney draft is approx. 20 to 50 Pa, depending on the height and the cross section of the chimney as well as the weather conditions. These values increase when the temperature increases. The draft stabiliser allows for setting the vacuum required by the manufacturer of the heating system (oil or gas burner/boiler combination, oil or gas furnace, etc.) and keeps this vacuum almost constant. Correct chimney draft is a prerequisite for an optimum combustion process and contributes to a reduction in heating costs.

The draft stabiliser performs the following functions:

- It limits the vacuum to the required value
- It keeps the chimney dry and prevents soot deposits

Technical specifications

Adjustment range (draft requirements):

10/26 Pa

Application area

Heights of up to 20 m and chimney group I/II up to 400 cm², chimney group III up to 500 cm²

Operating temperature range

Flue gas: Max. 400 °C

Mounting position

Flap axis horizontal
 Flap vertical

Tightness at Δp 10 Pa

< 3 m³/h

DG: G, PG: 3			Part no.	Price €
Draft stabiliser WZB-1	1	-	69760	
Mounting sleeves				
Chimney sleeve for WZB-1	1	-	69761	

Boiler water low level alarm WMS-WP6 – mechanical



- For protection of the boiler when the water level is too low
- TÜV-tested as a water level limiter
- Direct mounting via welding socket or connection thread
- With test button for function test



Version with connection thread R2 AG

Application For sealed heating systems to protect the boiler as per EN 12828 in the case of low water levels.

Description Mechanical boiler water low level alarm with float. Consisting of a cast brass body with welding sockets and a float mechanism, an electrical switch, test and unlock buttons. TÜV-tested as a water level limiter. If the water level in the boiler drops below a minimum level, a float activates a switch. The power supply to the boiler is interrupted. A locking mechanism keeps the burner from switching back on automatically. The test button allows the float to be lowered to simulate a low water alarm condition.

Version WMS-WP6-R2 with male connection thread R2 for direct installation in the boiler.

Technical specifications

Operating temperature range

Medium: Max. 120 °C
Ambient: Max. 120 °C

Housing

Cast brass
Height: 358 mm
Degree of protection: IP 54 (EN 60529)

Float

Plastic

Connection

Welding socket DN 20
or male thread R2

Operating pressure

Max. 10 bar

Test pressure

15 bar

Contact rating

AC 250 V, 6 (2) A

Type approval mark

TÜV.WBH.xx-232
"xx" = Year of VdTÜV certificate

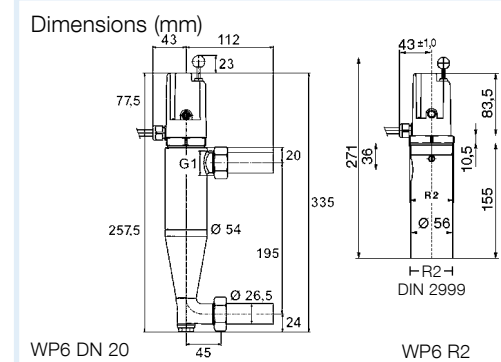

i

According to EN 12828, sealed heating systems with capacities of more than 300 kW must be equipped with a TÜV-tested boiler water low level alarm.

DG: G, PG: 2			Part no.	Price €
WMS-WP6 with welding socket DN 20	1	-	42300	
WMS-WP6 without locking, with welding socket DN 20	1	-	42305	
WMS-WP6-R2 with connection thread R2 male	1	-	42319	
Spare parts				
Upper part WMS-WP6 with locking	1	-	42310	
Upper part WMS-WP6 without locking	1	-	42311	
Probe body for WMS-WP6 DN 20	1	-	42368	

Thermal safety valve Combustion controllers

- High response temperature
- Short stem
- Very simple function test



Thermal safety valve TAS 03

Application To protect sealed or open solid fuel heating systems as per EN 12828 with a heating capacity of up to 86,000 kcal. Also required for dual-fuel boilers which can be operated with solid fuels.

Description Thermal safety valve with two independent sensor systems. TAS consists of a valve housing, a valve, two independent bellows type displacement probes with liquid-filled temperature probes and a pocket. The capillary tube is protected by a flexible metal hose. TAS is connected to the water outlet of the water heater or to the inlet of the safety heat exchanger. If the response temperature is exceeded, the valve is opened by the thermal probe and cooling water is supplied to keep the system from exceeding the maximum operating temperature. Correct operation of TAS can be verified quickly and easily by simply pressing the valve head.

Technical specifications

Operating pressure: Max. 10 bar

Operating temperature range: Ambient: 80 °C

Response temperature: 99 °C

Blow-off capacity

At 110 °C and $\Delta p = 1 \text{ bar} > 2.4 \text{ m}^3/\text{h}$

Connections: 2 x G $\frac{3}{4}$ female thread

Connection stem: G $\frac{1}{2}$ male thread

Dimensions

Pocket length: 146 mm

Capillary tube length: 1,300 or 4,000 mm

Housing: Hot-pressed brass



Combustion controller FR 1

For temperature-dependent adjustment of the air supply damper of solid fuel and dual-fuel boilers.



The FR 1 combustion controller controls the combustion air supply. The temperature in the heat generator is detected by an integrated thermostat. The thermostat is connected to the air supply damper by means of a lever and a chain. The air supply is controlled by means of opening or closing the air supply damper, depending on the boiler flow temperature.

Control range: 30/90 °C

Operating temperature range

Medium: Max. 115 °C

Ambient: Max. 70 °C (at switching button)

Connection: G $\frac{3}{4}$

Dimensions

Stem length: 53 mm, chain length: 1.2 m

Chain load: 100 to 600 g

Mounting position: Horizontal or vertical

Materials

Housing: Plastic

Stem: Brass

Lever/chain: Galvanised steel

7



See chapter 12 for the complete range of temperature measuring instruments and controllers.

DG: G, PG: 2			Part no.	Price €
Thermal safety valve TAS 03 , capillary tube 1.3 m	1	-	42415	
Thermal safety valve TAS 03 , capillary tube 4 m	1	-	42418	
Screw connector kit for TAS 03	1	20	42450	
Pocket G$\frac{1}{2}$ for TAS 03	1	10	42449	
Combustion controller FR 1	1	10	42294	

Automatic quick air vents PrimoVent



Air in the system is a frequent cause of malfunctions of heating, cooling and solar systems. The cause of "air in the system" should be able to be removed. However, there are no systems that are always 100 % tight. The AFRISO PrimoVent product family continuously and automatically removes air from heating and solar systems, thus helping to avoid corrosion caused by air and inclusion of air in systems. AFRISO quick air vents are available as brass, plastic or hybrid versions and are always subjected to a 100 % function test prior to shipment.

Universal application for water and water-glycol mixtures (max. 50 % glycol)



Cover with patented nozzle geometry: The slot-shaped vent opening provides for a high venting capacity.

7

Integrated aqua stop for reliable operation without water leakage. The protective cap does not need to be removed even during initial filling or maintenance.

Protective cap for vent, cannot be lost.

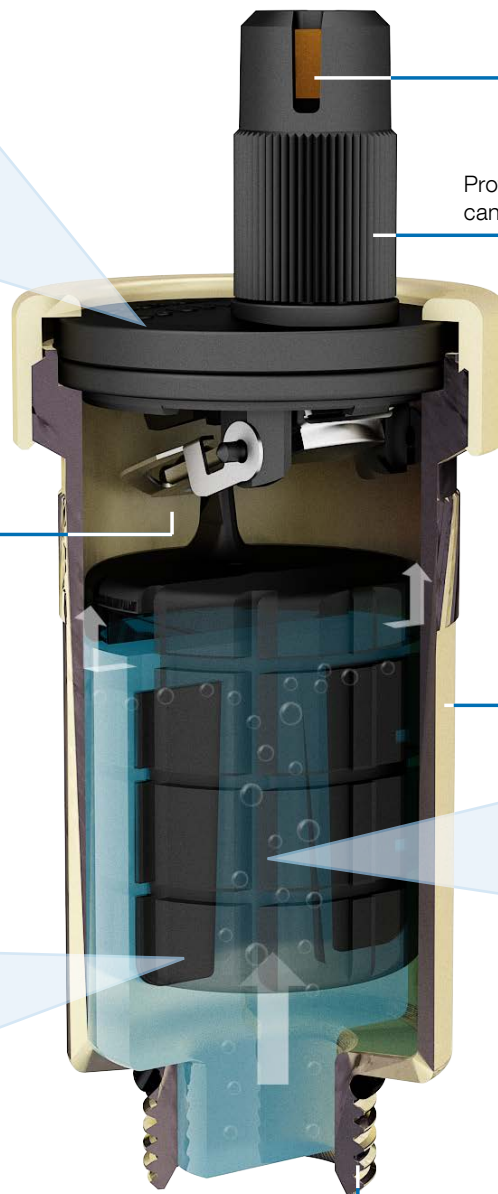

Slim design for low heat loss – ideal for installations where space is limited.

Multifunctional lever for dependable opening and closing of the valve – directly connected to the float so that disconnection is not possible.



Two-way venting principle: separated air escapes via the central hole in the float in a defined way without taking along water.



Optimised float geometry for minimum capillary effect – avoids the formation of an air cushion to suppress undefined "jumps" of the float.

Depending on the version: Brass or plastic connection, G^{3/8} or G^{1/2} with O ring seal.

i Mounting valves for quick air vents ensure easy, fast installation. Dismounting is possible at any time without draining the system.

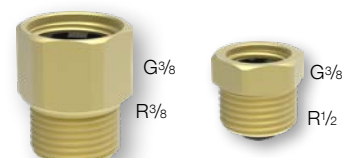

Quick air vent PrimoVent



Quick air vent 12 bar

Application For automatic venting of sealed heating systems as per EN 12828. Suitable for up to 12 bar/110 °C for water and water/glycol mixtures with up to 50 % glycol.

Description Automatic quick air vent with mounting valve and aqua stop. The vent cap does not have to be removed during operation of the quick air vent, not even for initial filling or servicing. Its high, narrow design is perfect in terms of appearance and function. Self-sealing connection thread.

Technical specifications

Connection
G^{3/8} or G^{1/2}

Operating temperature range
Max. 110 °C

Nominal pressure
Max. 12 bar

Housing
Brass

Cover
Glass-fibre reinforced plastic

Union ring
Brass

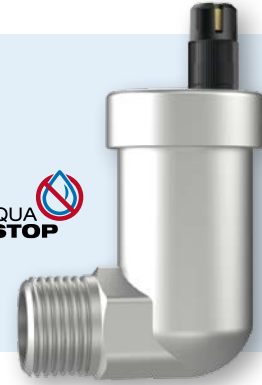

Angled quick air vent 12 bar

For automatic venting of radiators. Suitable up to 12 bar/110 °C for water and water/glycol mixtures with up to 50 % glycol.

Automatic quick air vent with aqua stop. The vent cap does not have to be removed during operation of the quick air vent, not even for initial filling or servicing.

Connection
R^{1/2} as per DIN 3858

Operating temperature range
Max. 110 °C

Nominal pressure
Max. 12 bar

Housing
Brass, nickel-plated

Cover
Glass-fibre reinforced plastic

Union ring
Brass, nickel-plated

7



Mounting valves as accessories for quick air vents:

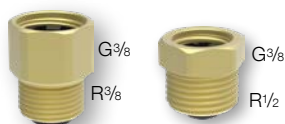

DG: G, PG: 2	Mounting valve			Part no.	Price €
Quick air vent G^{3/8}	R ^{3/8}	1	25	77700	
Quick air vent G^{3/8}	R ^{1/2}	1	25	77706	
Quick air vent G^{3/8}	Without	1	25	77710	
Quick air vent G^{1/2}	Without	1	25	77752	
Angled quick air vent R^{1/2}, with aqua stop	Without	1	10	77753	
Accessories					
Mounting valve R^{3/8} x G^{3/8}		–	25	77720	
Mounting valve R^{1/2} x G^{3/8}		–	25	77723	

Quick air vent PrimoVent



Plastic quick air vent

Application For automatic venting of sealed heating systems as per EN 12828. Suitable for water and water/glycol mixtures with up to 50 % glycol.

Description Automatic quick air vent made of high-grade glass-fibre reinforced plastic, with aqua stop. The vent cap does not have to be removed during operation of the quick air vent, not even for initial filling or servicing. Its high, narrow design is perfect in terms of appearance and function. Sealing by means of O ring. Mounting valves available as accessories.

Technical specifications

Connection
G³/₈ or G¹/₂ with O ring

Operating temperature range
Depending on nominal pressure
Max. 95/120 °C
See operating instructions

Nominal pressure
At 95 °C: Max. 8 bar
At 120 °C: Max. 3.5 bar

Housing
Glass-fibre reinforced plastic

Latching ring
Glass-fibre reinforced plastic



Quick air vent Hybrid

For automatic venting of sealed heating systems as per EN 12828. Suitable for water and water/glycol mixtures with up to 50 % glycol.

Automatic quick air vent made of high-grade glass-fibre reinforced plastic, with aqua stop. The vent cap does not have to be removed during operation of the quick air vent, not even for initial filling or servicing. Its high, narrow design is perfect in terms of appearance and function. Sealing by means of O ring. Mounting valves available as accessories.

Connection
G³/₈, brass with O ring

Operating temperature range
Depending on nominal pressure
Max. 95/120 °C
See operating instructions

Nominal pressure
At 95 °C: Max. 8 bar
At 120 °C: Max. 3.5 bar

Housing
Glass-fibre reinforced plastic

Latching ring
Glass-fibre reinforced plastic



Mounting valves as accessories for quick air vents:

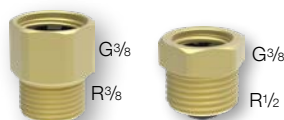

DG: G	Mounting valve	PG			Part no.	Price €
Plastic quick air vent G³/₈	Without	1	1	25	77766	
Plastic quick air vent G¹/₂	Without	1	1	25	77761	
Quick air vent Hybrid G³/₈	Without	1	1	25	77729	
Quick air vent Hybrid G³/₈	R ³ / ₈	1	1	25	77730	
Accessories						
	Mounting valve R³/₈ x G³/₈	2	-	25	77720	
	Mounting valve R¹/₂ x G³/₈	2	-	25	77723	

Boiler safety group assemblies KSG



KSG Mini – 2.5 bar/3 bar

Application For sealed heating systems as per EN 12828 with a capacity of up to 50 kW.

Description Complete, pre-assembled, tightness-tested boiler safety group assembly, lightweight design. Consisting of carrier, pressure gauge for indicating the system pressure, quick air vent and diaphragm safety valve MS, including form-fit insulation. With self-sealing mounting valve for easy replacement of the quick air vent.

Technical specifications

Connection boiler

G1 female thread

Operating temperature range

Max. 120 °C

Dimensions

W x H x D: 147 x 140 x 70 mm

Insulation

Polystyrene EPS

Carrier

Brass

Diaphragm safety valve MS

Inlet x outlet: Connector x G $\frac{3}{4}$

Seal: EPDM sealing ring

Response pressure: 2.5 bar or 3 bar

Pressure gauge for heating installations

Range: 0/4 bar

Diameter: 50 mm – with plug connection bottom back

Quick air vent with aqua stop

Inlet: G $\frac{3}{8}$

Nominal pressure: 12 bar



KSG – 3 bar

For sealed heating systems as per EN 12828 with a capacity of up to 50 kW.

Complete, pre-assembled, tightness-tested boiler safety group assembly. Consisting of carrier, pressure gauge for indicating the system pressure, quick air vent with aqua stop and diaphragm safety valve MS, including form-fit insulation. With self-sealing mounting valve for easy replacement of the quick air vent.

Connection boiler

G1 female thread

Operating temperature range

Max. 120 °C

Dimensions

Prin: 183 x 144 x 70 mm

Insulation

Expanded polypropylene EPP

Carrier

Brass

Diaphragm safety valve MS

Inlet x outlet: G $\frac{1}{2}$ x G $\frac{3}{4}$

Seal: PTFE sealing ring, can be rotated

Response pressure: 3 bar

Pressure gauge for heating installations

Range: 0/4 bar

Diameter: 63 mm – G $\frac{1}{4}$ bottom

Quick air vent with aqua stop

Inlet: G $\frac{3}{8}$

Nominal pressure: 12 bar

7

DG: G, PG: 2	kW	bar	Connection	Insulation			Part no.	Price €
KSG Mini, 2.5 bar	Max. 50	2.5	G1	Yes	1	10	77351	
KSG Mini, 3 bar	Max. 50	3	G1	Yes	1	10	77350	
KSG	Max. 50	3	G1	Yes	1	10	77938	

Boiler safety group assemblies KSG



KSG Maxi – 3 bar

Application For sealed heating systems as per EN 12828 with a capacity of up to 100 kW.

Description Complete, pre-assembled, tightness-tested boiler safety group assembly. Consisting of carrier, pressure gauge for indicating the system pressure, quick air vent with aqua stop and diaphragm safety valve MS, in form-fit insulation. With self-sealing mounting valve for easy replacement of the quick air vent.

Technical specifications

Connection boiler

G1 female thread

Operating temperature range

Max. 120 °C

Dimensions

W x H x D: 183 x 144 x 70 mm

Insulation

Expanding polypropylene EPP

Carrier

Brass

Diaphragm safety valve MS

Inlet x outlet: G $\frac{3}{4}$ x G1

Seal: PTFE sealing ring, can be rotated

Response pressure: 3 bar

Pressure gauge for heating installations

Range: 0/4 bar

Diameter: 63 mm – G $\frac{1}{4}$ centre back

Quick air vent with aqua stop

Inlet: G $\frac{3}{8}$

Nominal pressure: 12 bar

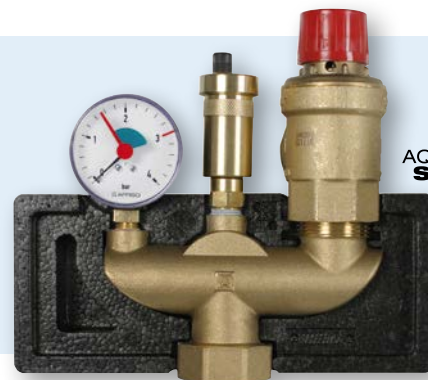

KSG Magnum – 3 bar

For sealed heating systems as per EN 12828 with a capacity of up to 200 / 350 kW.

Complete, pre-assembled, tightness-tested boiler safety group assembly. Consisting of carrier designed as multi-way union, pressure gauge for indicating the system pressure, quick air vent with aqua stop and diaphragm safety valve MS. With self-sealing mounting valve for easy replacement of quick air vent. The form-fit insulation is also used to package the product for safe transport.

Connection boiler

Up to 200 kW: G1 $\frac{1}{4}$ with union nut

Up to 350 kW: G1 $\frac{1}{2}$ with union nut

Operating temperature range

Max. 120 °C

Dimensions

W x H x D: 230 x 190 x 105 mm

Insulation

Expanding polypropylene EPP

Carrier

Brass

Diaphragm safety valve MS

Up to 200 kW (inlet x outlet): G1 x G1 $\frac{1}{4}$

Up to 350 kW (inlet x outlet): G1 $\frac{1}{4}$ x G1 $\frac{1}{2}$

Seal: PTFE sealing ring, can be rotated

Response pressure: 3 bar

Pressure gauge for heating installations

Range: 0/4 bar

Diameter: 63 mm – G $\frac{1}{4}$ bottom

Quick air vent with aqua stop

Inlet: G $\frac{3}{8}$

Nominal pressure: 12 bar

DG: G, PG: 2	kW	bar	Boiler connection	Insulation			Part no.	Price €
KSG Maxi	Max. 100	3	G1 female	Yes	1	10	77581	
KSG Magnum G1$\frac{1}{4}$	Max. 200	3	G1 $\frac{1}{4}$ female	Yes	1	10	77627	
KSG Magnum G1$\frac{1}{2}$	Max. 350	3	G1 $\frac{1}{2}$ female	Yes	1	10	77628	

Connection assembly for expansion vessel GAK – steel

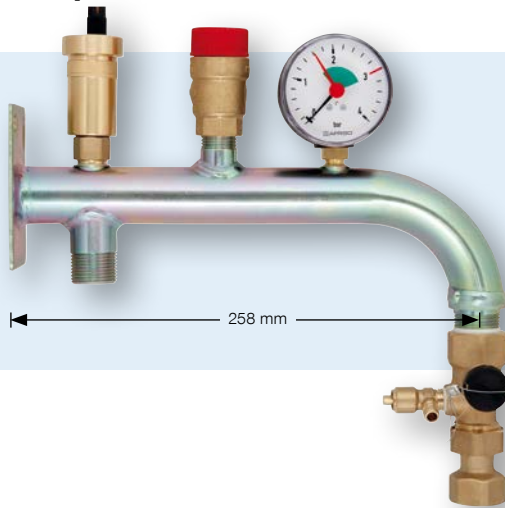

- Time-saving installation with pre-assembled, tightness-tested assembly
- Service-friendly:
Air vent and expansion vessel can be replaced without draining

Application For connection of diaphragm expansion vessels up to 50 l for sealed heating systems as per EN 12828 up to a capacity of 50 kW.

Description Pre-assembled combination fitting consisting of:

- Steel carrier with enclosed anti-tamper cap valve for connection of the diaphragm expansion vessel
- Safety valve with type approval
- Pressure gauge for heating installations with red reference pointer
- Quick air vent (12 bar), mounted via self-sealing mounting valve

Technical specifications

Connections

Boiler: G $\frac{3}{4}$ female thread
Expansion vessel: G $\frac{3}{4}$ female thread

Operating temperature range

Medium: Max. 120 °C

Dimensions

W x H x D: Approx. 258 x 268 x 70 mm

Carrier

Steel, galvanised, protrusion 260 mm

Diaphragm safety valve MS

Inlet x outlet: G $\frac{1}{2}$ x G $\frac{3}{4}$
Seal: Teflon ring, rotatable
Response pressure: 3 bar
Heat capacity: 50 kW

Pressure gauges for heating installations

Bourdon tube pressure gauges
Range: 0/4 bar, with red reference pointer
Diameter: 63 mm – G $\frac{1}{4}$ bottom

Quick air vent with aqua stop

Inlet: G $\frac{3}{8}$
Nominal pressure: 12 bar

Scope of delivery

- GAK
- Mounting accessories:
Screws, washers, dowels
- Anti-tamper cap valve (not mounted)

7

DG: G, PG: 3			Part no.	Price €
GAK 3 bar Steel	1	-	77470	

Connection assembly for expansion vessel GAK

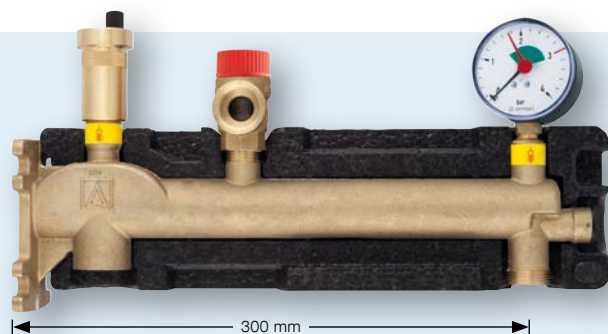

- Time-saving installation with pre-assembled, tightness-tested assembly
- Service-friendly: Pressure gauge, air vent and expansion vessel can be replaced without draining
- Reliable venting due to top-mounted connection for quick air vent

Application For connection of diaphragm expansion vessels up to 50 l for sealed heating systems as per EN 12828 up to a capacity of 50 kW.

- Description** Pre-assembled combination fitting consisting of:
- Carrier made of solid cast brass with integrated anti-tamper cap valve for connection of the diaphragm expansion vessel
 - Safety valve with type approval
 - Pressure gauge for heating installations with red reference pointer, mounted via self-sealing mounting valve
 - Quick air vent (12 bar), mounted via self-sealing mounting valve
 - Two form-fit insulation shells

Technical specifications

Connections

Boiler: G $\frac{3}{4}$ female thread
Expansion vessel: G $\frac{3}{4}$ female thread

Operating temperature range

Medium: Max. 120 °C

Dimensions (with insulation)

W x H x D: 360 x 185 x 100 mm

Insulation

Expanded polypropylene EPP

Carrier

Brass, protrusion 300 mm

Diaphragm safety valve MS

Inlet x outlet: G $\frac{1}{2}$ x G $\frac{3}{4}$
Seal: Teflon ring, rotatable
Response pressure: 3 bar
Heat capacity: 50 kW

Pressure gauges for heating installations

Bourdon tube pressure gauge with self-sealing mounting valve
Range: 0/4 bar, with red reference pointer
Diameter: 63 mm – G $\frac{3}{8}$ bottom

Quick air vent with aqua stop

Inlet: G $\frac{3}{8}$
Nominal pressure: 12 bar

Scope of delivery

- GAK
- 2 insulation shells
- Mounting accessories: Screws, washers, dowels, seal, seal, screw connection G $\frac{3}{4}$ female x G $\frac{3}{4}$ union nut for connection of the expansion vessel

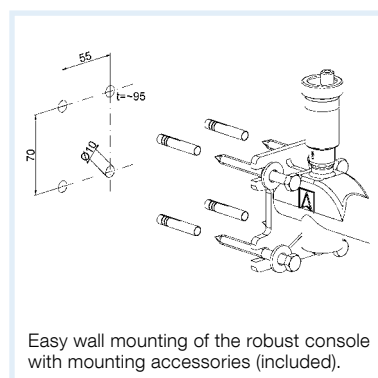

DG: G, PG: 2			Part no.	Price €
GAK 3 bar with insulation	1	-	77932	

Air separator



- Pre-assembled, tightness-tested and heat-insulated assembly
- Continuous, automatic venting of the system
- Cost savings due to fewer malfunctions and longer service life of the system
- Fast and easy integration into existing pipes via reducer unions

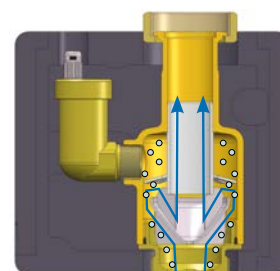

Function principle

Application For removing air from heating systems. The air separator ensures reliable operation, better and faster heat transfer and thus contributes to reduced fuel consumption and emissions. Suitable for hot water heating systems and underfloor heating systems. Air is removed from the system without chemical additives.

Description Compact air separator with integrated quick air vent in form-fit insulation. The new function principle with two separation chambers ensures a reduced flow speed for effective separation of air and water. The lower the flow rate in the separator, the better the air bubbles can be removed from the water due to the difference in density. The air bubbles rise, collect in the upper area in a calm zone and are automatically removed by means of the quick air vent without taking along water. The quick air vent features an aqua stop to keep water from escaping. The air separator can be installed in the flow (preferred) or return line. Reducer unions G1 female and G $\frac{3}{4}$ female are available for renovation or retrofitting in existing pipes.

Technical specifications

Housing

Brass

Insulation

EPP

Operating pressure

Max. 10 bar

Operating temperature range

Max. 95 °C

Connections

Top G1½ female (union nut)

Bottom G1½ male

Mounting position

Vertical

Dimensions (mm)

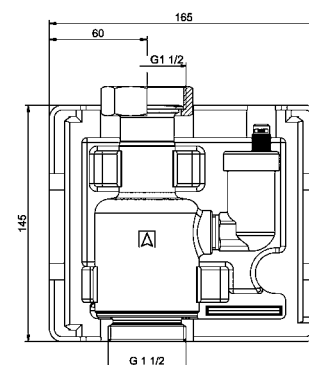

DG: G, PG: 2	Part no.	Price €
Air separator G1½	40682	
Accessories		
Reducer union kit G1 female	40684	
Reducer union kit G¾ female	40685	

Sludge separator



- Pre-assembled, tightness-tested and heat-insulated assembly
- Single-operation cleaning while the system is running
- Energy savings due to improved heat transfer at system components
- Fast and easy integration into existing pipes via reducer unions

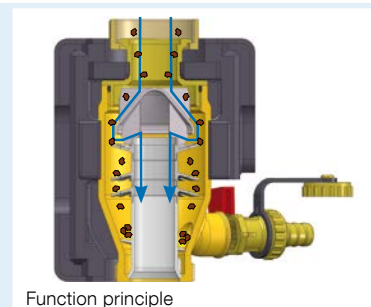

Function principle

Application For removing dirt particles from heating systems. Particles can cause problems in fittings and control units. The sludge separator ensures clean water, reliable operation, better and faster heat transfer and thus contributes to reduced fuel consumption and emissions. Suitable for hot water heating systems and underfloor heating systems. Rust, lime particles, calcium, magnesium, oxides, carbonates and sludge as well as larger particles such as chips or construction residues are removed from the water – without the use of chemicals. Excellent for the renovation of system parts subject to sludge accumulation.

Description Compact sludge separator with drain valve in form-fit insulation. The highly efficient concept removes sludge from the water. Plates in the separator deflect the particles into a separate area. From there, the dirt particles can be flushed out during normal operation by means of a valve. The sludge separator can be combined with the air separator and can be installed in the flow (preferred) or return lines. Reducer unions G1 female and G $\frac{3}{4}$ female are available for renovation or retrofitting in existing pipes.

Technical specifications

Housing

Brass

Insulation

EPP

Operating pressure

Max. 10 bar

Flow coefficients NS

13.6 m³/h (flow top down)14.7 m³/h (flow bottom up)

Operating temperature range

Max. 95 °C

Connections

Top G1½ female (union nut)

Bottom G1½ male

Mounting position

Vertical

Dimensions (mm)

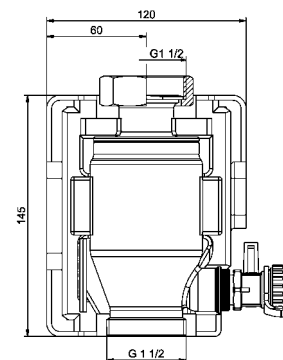

DG: G, PG: 2	Part no.	Price €
Sludge separator G1½	40683	
Accessories		
Reducer union kit G1 female	40684	
Reducer union kit G¾ female	40685	

Flow filters, combined air/flow filters

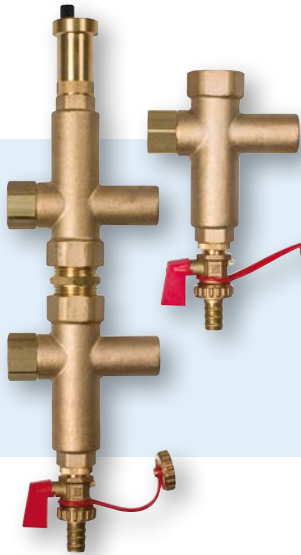

- Dirt particle separator
- Suitable for open and sealed circuits
- Flushing possible during operation of the system
- Cost savings due to fewer malfunctions and longer service life of the system
- Energy savings due to improved heat transfer at clean system components

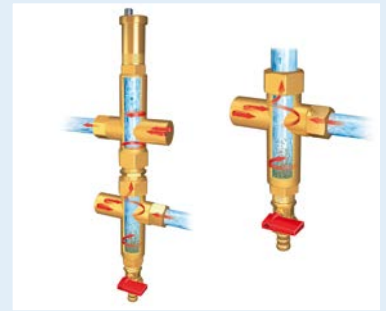

Application Flow filters and combined air/flow filters remove lime, rust, sludge, dirt and gas from heating systems to provide clean water and trouble-free operation. Suitable for hot water heating systems, underfloor heating systems, fuel cells and renovation of system components (sludge removal).

Description Most advanced heating systems use water for heat transmission. This water may also transport unwanted substances such as lime, calcium, magnesium, oxide, carbonates as well as larger particles such as welding or soldering residue, metal chips and dirt. These substances may cause malfunctions in fittings and control units. A compact flow filter (particle separator) removes these particles from the water. The particles settle in the collection chamber of the filter and can be flushed out via a valve with small amounts of water. Clean water supports trouble-free operation of systems and reduces the fuel and maintenance costs.

Clean system components have better thermal conduction, they provide for faster heating up and thus contribute to reduced fuel consumption and emissions.

The combined air/flow filter was developed for heating systems which are subject to problems caused by oxygen or other gases. The vent valve automatically removes the gases.

Technical specifications

Housing

Brass

Operating pressure

Max. 10 bar

Operating temperature range

Max. 95 °C

Dimensions (W x H x D)

Flow filter: 120 x 194 x 60 mm

Combined air/flow filter: 120 x 394 x 60 mm

Connections



Flow filter: Inlet G $\frac{3}{4}$

Outlet G1

Combined air/flow filter: 2 x G $\frac{3}{4}$

Scope of delivery

Flow filters and combined air/flow filters are delivered with form-fit insulation.

DG: G, PG: 2				Part no.	Price €
Flow filter – heating	28 kW	1	5	78210	
Flow filter – heating	50 kW	1	5	78211	
Combined air/flow filter – heating	28 kW	1	5	78212	
Combined air/flow filter – heating	50 kW	1	5	78213	

Anti-tamper cap valves



High draining capacity for easy and fast draining



Anti-tamper cap valve with integrated boiler filling and drain valve KFE

Application For connection, maintenance and checks of diaphragm expansion vessels in heating systems as per EN 12828 and in solar systems. To be installed at the water inlet of the expansion vessel.

Description Anti-tamper cap valve with screw connection $G\frac{3}{4}$ x $G\frac{3}{4}$ or G1 x G1. The shut-off valve is secured against inadvertent closing by means of a cap and a lead seal. The integrated boiler filling and drain valve KFE (connection: $G\frac{3}{4}$ eurocone) allows for easy draining of the expansion vessel. For this purpose, a hose can be connected by means of a union nut. The expansion vessel can be shut off from the heating system and drained with a high draining capacity (time saving) via the drain valve for the required function test or for replacement.

Technical specifications

Operating pressure

Max. 10 bar

Operating temperature range

Operation: 0/120 °C

Drain capacity

Flow coefficient Kvs: 1.5 m³/h

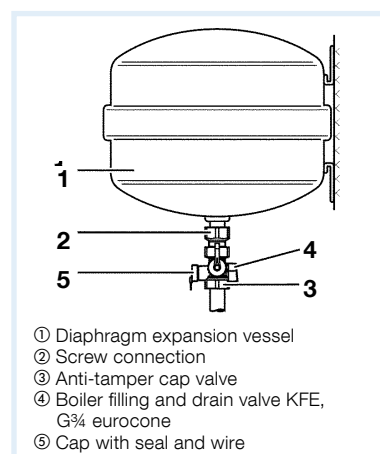

Anti-tamper cap valve with drain valve

Anti-tamper cap valve with screw connection $G\frac{3}{4}$ x $G\frac{3}{4}$ or G1 x G1. The shut-off valve is secured against inadvertent closing by means of a cap and a lead seal. Valve operation via standard square spanner size 5 for radiator vent valves. The expansion vessel can be shut off from the heating system and drained via the drain valve for the required function test or for replacement.

Operating pressure

Max. 10 bar

Operating temperature range

Operation: 0/120 °C

Drain capacity

Flow coefficient Kvs: 0.5 m³/h

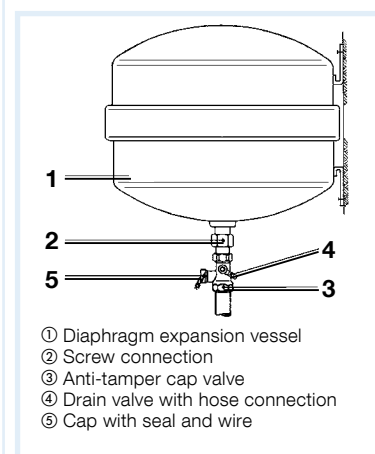

DG: G, PG: 2

			Part no.	Price €
Anti-tamper cap valve $G\frac{3}{4}$ x $G\frac{3}{4}$ with integrated boiler filling and drain valve KFE $G\frac{3}{4}$	1	25	77949	
Anti-tamper cap valve G1 x G1 with integrated boiler filling and drain valve KFE $G\frac{3}{4}$	1	25	77950	
Anti-tamper cap valve $G\frac{3}{4}$ x $G\frac{3}{4}$ with drain valve	1	25	77924	
Anti-tamper cap valve G1 x G1 with drain valve	1	25	77934	
Spare part seal kit	1	-	77493	

Diaphragm safety valves MS, MSM



- For protection against overpressure in heating systems
- For water, water/glycol mixtures, liquids of fluid groups 1 and 2
- MSM with pressure gauge for indication of the system pressure

MSM with pressure gauge for heating systems



Application For sealed heating systems as per TRD 721; VdTÜV sheet Safety Valve 100 and 100/4 sheet 1; EN 12828. Also for water heating systems as per DIN 4751-2 with flow temperatures up to 120 °C and DIN 4751-3 with flow temperatures up to 95 °C. Suitable for water, water/glycol mixtures (max. 50 % glycol) and liquids of fluid groups 1 and 2 (Pressure Equipment Directive, Art. 9).

Description Safety valve with factory-adjusted opening pressure. MSM with pressure gauge for indicating the system pressure. The size of the valve inlet determines the unit type, the outlet is ¼" larger.

Technical specifications

Connection

See selection table

Operating temperature range

-20/+120 °C

Opening pressure

See selection table

Dimensions

W x H x D: 35 x 60 x 45 mm

Housing

Brass

Cap

PA6, red



Pressure gauge for heating installations (for MSM)

Diameter: 50 mm – G¼ back

Range: 0/4 bar

Connection: Bottom back

7

DG: G, PG: 2	Maximum heating capacity	Opening pressure*	Pressure gauges			Part no.	Price €
MS G½ x G¾	50 kW	2.5 bar	–	1	84	42385	
MS G½ x G¾	50 kW	3.0 bar	–	1	84	42390	
MS G¾ x G1	100 kW	2.5 bar	–	1	84	42386	
MS G¾ x G1	100 kW	3.0 bar	–	1	84	42391	
MS Rp1 x Rp1¼	200 kW	2.5 bar	–	1	-	42383	
MS Rp1 x Rp1¼	200 kW	3.0 bar	–	1	-	42378	
MS Rp1¼ x Rp1½	350 kW	3.0 bar	–	1	-	42495	
MSM G½ x G¾	50 kW	3.0 bar	0/4 bar	1	30	42382	

* Enquire for other pressure ratings and connections.

i See pages 199, 286 for safety valves for solar liquid and drinking water.

Differential pressure bypass valves DÜ



- For constant pump pressure in heating systems
- Reduction of flow noise
- With adjustment scale
- Differential pressure fully adjustable
- Either space-saving angled version or straight version

Application For keeping the pump pressure in sealed heating systems as per EN 12828 constant and for reducing flow noise in the heating system.

Description Differential pressure bypass valve with directly readable adjustment scale. Housing made of brass. Available as straight version or angled version for space-saving installation. The differential pressure in the heating system at full load is set directly at the bypass valve. If the volume flow is reduced, the valve opens to keep the head of the circulation pump constant.

Technical specifications

Operating temperature range
Max. 95 °C, (short-term 120 °C)

Operating pressure
Max. 6 bar

Differential pressure
Fully adjustable 0.1/0.5 bar

Housing
Angled version or straight version
Material: Brass

Connection angled version

Inlet: G $\frac{3}{4}$ female thread
Outlet: Screw connection, flat-sealing with union nut G $\frac{3}{4}$

Connection straight version

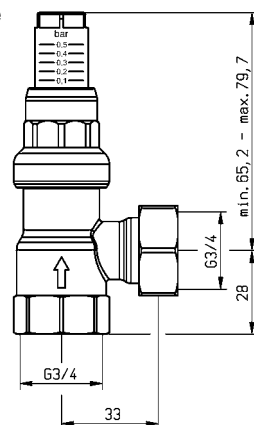

Screw connection at both sides, flat-sealing with union nut G $\frac{3}{4}$

Differential pressure bypass valve
Angled version

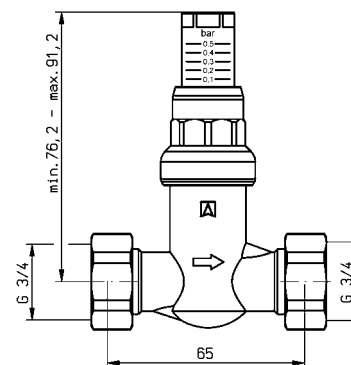

Differential pressure bypass valve straight version



DG: G, PG: 2			Part no.	Price €
DÜ with screw connection, angled version	1	10	42379	
DÜ with screw connection, straight version	1	-	42384	

Filling and drain fittings



Filling fitting FAM

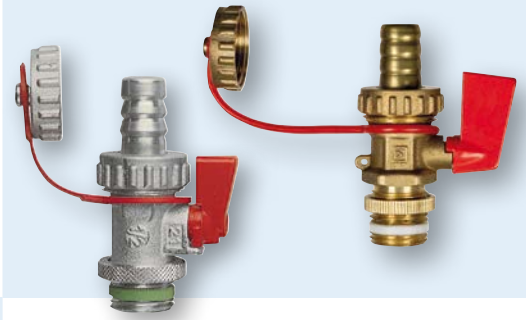

Boiler filling and drain valve KFE, brass, plain Boiler filling and drain valve KFE, brass, nickel-plated

Filling fittings FA / FAM

Application For sealed heating systems as per EN 12828.

Description Filling fitting with housing and spring cap made of brass. Inlet for hose inside diameter 12 mm, outlet G $\frac{1}{2}$ female thread. With G $\frac{1}{4}$ connection for pressure gauge for heating installations. With pressure reducer, shut-off valve and back-flow preventer. Inlet pressure 6 up to 10 bar, outlet pressure adjustable between 0.5 and 3 bar. Version FAM with pressure gauge for heating installations \varnothing 63 mm, 0/4 bar, G $\frac{1}{4}$ bottom.



For sealed heating systems as per EN 12828.

Boiler filling and drain valve. Ball valve version made of brass. One side G $\frac{1}{2}$ male thread with PTFE sealing ring, other side $\frac{1}{2}$ " hose connector with G $\frac{3}{4}$ union nut and blind cap with chain or strap. Available in plain brass (drinking water) or nickel-plated brass (heating circuit water).

7



Filling fitting FA

DG: G, PG: 2			Part no.	Price €
Filling fitting FA	1	5	42405	
Filling fitting FAM	1	5	42406	
Boiler filling and drain valve KFE, brass plain, in cardboard box	12	72	42401	
Boiler filling and drain valve KFE, brass nickel-plated, in cardboard box	12	72	42407	

Flow meter DFM 10-1M



- Direct indication of the flow rate in l/min
- Compact design

Dimensions
(mm)

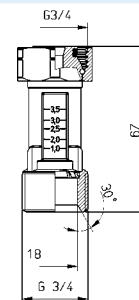

Application For monitoring the flow in heating/cooling systems. Specially for direct mounting to heating circuit manifolds. Suitable for heating and cooling water as well as water mixtures with standard corrosion protection and antifreeze agents.

Description Compact flow meter with scale. The flow meter can be installed in pipes in a horizontal, tilted or vertical position. The reading mark corresponds to the lower edge of the rotameter/float.

Technical specifications

Operating temperature range

Max. 100 °C

Operating pressure

Max. 10 bar

Measuring principle

Rotameter type with counter spring

Measuring range

1–3.5 l/min

Nominal diameter

DN 10

Housing

Brass

Connection

G $\frac{3}{4}$ x G $\frac{3}{4}$ (eurocone)
male thread x union nut

Mounting position

Horizontal, tilted or vertical



Please enquire for other versions.

DG: G, PG: 2			Part no.	Price €
DFM 10-1M	-	10	78619	

Flow meters

DFM 15-2M / DFM 20-2M



- Integrated ball valve for adjustment and shutting off
- Direct indication of the flow rate in l/min
- Adjustment without diagram, table or measuring instrument
- Available with numerous connection versions

Application For hydraulic balancing and flow monitoring in heating/cooling systems, air conditioning systems, solar systems and geothermal systems. DFM allows for fast hydraulic balancing of the system or of system components without diagrams, tables or measuring instruments. Suitable for heating and cooling water as well as water mixtures with standard corrosion protection and antifreeze agents.

Description Compact flow meter with scale and ball valve for shutting off and adjustment. The flow meter can be installed in pipes in a horizontal, tilted or vertical position. Adjustments are made by means of a screwdriver via the adjustment screw. The reading mark corresponds to the lower edge of the rotameter/float. Systems with correct hydraulic balancing provide for optimum energy distribution and cost-efficient operation.

Technical specifications

Operating temperature range

120 °C, short-term 160 °C

Operating pressure

Max. 10 bar

Measuring principle

Rotameter type with counter spring

Measuring range

See ordering table

Nominal diameter

DN 15, DN 20

Housing

Brass

System connections

G $\frac{3}{4}$ x G $\frac{3}{4}$, G1 x G1, G1 $\frac{1}{4}$ x G1 $\frac{1}{4}$

Male thread x male thread,
male thread x union nut

Mounting position

Horizontal, tilted or vertical

Options

- Other nominal diameters
- Other connections
- Other measuring ranges

Flow coefficients NS

Nominal diameter	Measuring range	Flow coefficient Kvs
DN 15	1–6 l/min	2.1 m ³ /h
DN 15	2–12 l/min	3.0 m ³ /h
DN 15	8–28 l/min	4.8 m ³ /h
DN 15	8–38 l/min	5.9 m ³ /h
DN 20	5–42 l/min	9.7 m ³ /h
DN 20	20–70 l/min	12.9 m ³ /h



Please enquire for other versions.

Flow meters DFM 15-2M / DFM 20-2M

Types and dimensions (mm)

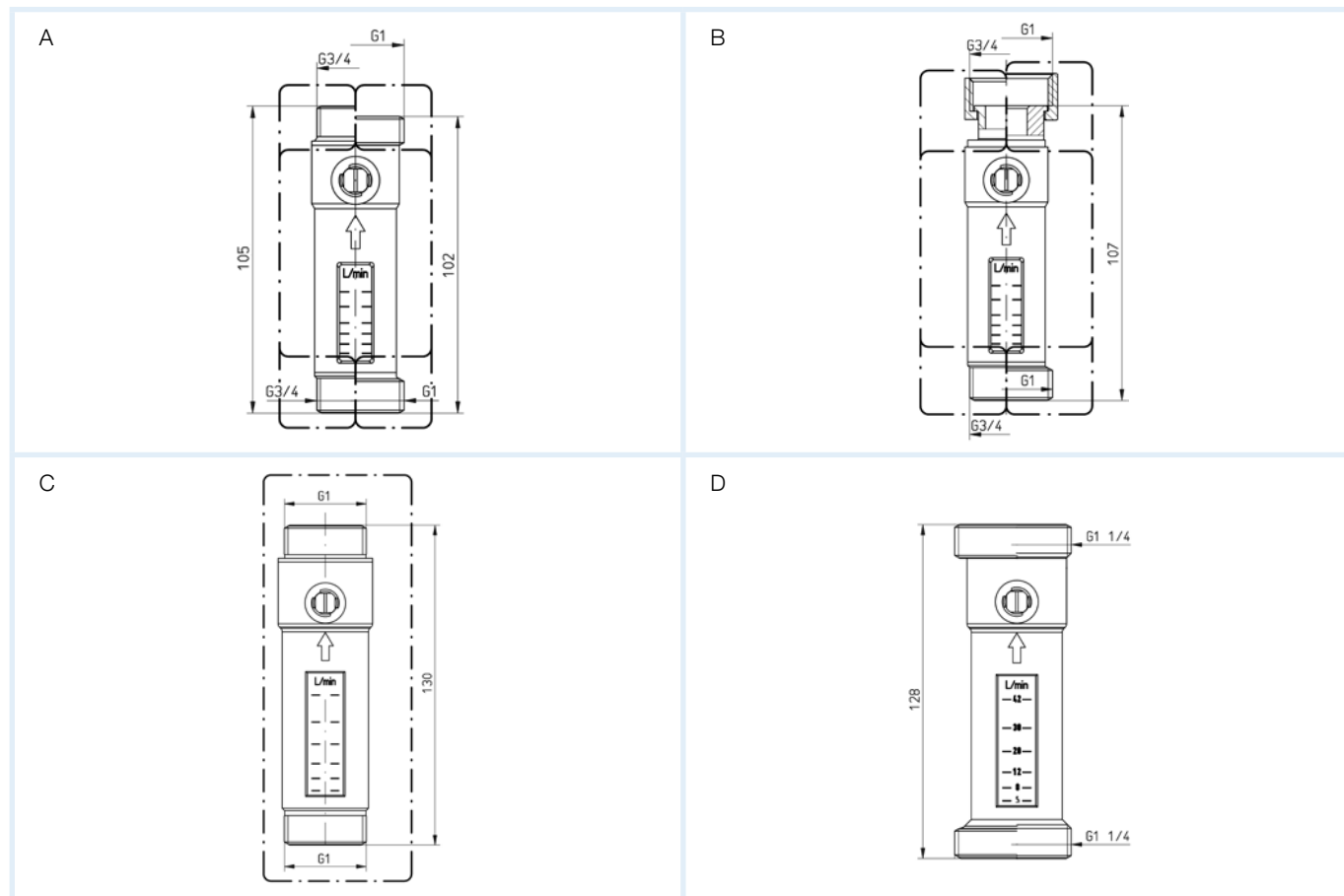

7

DG: G, PG: 2 **Male thread x male thread**

Type	Nominal diameter	Connections	Measuring range	Part no.	Price €
DFM 15-2M					
A	DN 15	G $\frac{3}{4}$ x G $\frac{3}{4}$	1-6 l/min	80958	
	DN 15		2-12 l/min	80963	
	DN 15		8-28 l/min	80968	
	DN 15		8-38 l/min	80973	
	DN 15	G1 x G1	1-6 l/min	80959	
	DN 15		2-12 l/min	80964	
	DN 15		8-28 l/min	80969	
	DN 15		8-38 l/min	80974	
DFM 20-2M					
C	DN 20	G1 x G1	5-42 l/min	80978	
	DN 20		20-70 l/min	80983	
D	DN 20	G1 $\frac{1}{4}$ x G1 $\frac{1}{4}$	5-42 l/min	80979	
	DN 20		20-70 l/min	80984	

Male thread x union nut

Type	Nominal diameter	Connections	Measuring range	Part no.	Price €
DFM 15-2M					
B	DN 15	G $\frac{3}{4}$ x G $\frac{3}{4}$	1-6 l/min	80960	
	DN 15		2-12 l/min	80965	
	DN 15		8-28 l/min	80970	
	DN 15		8-38 l/min	80975	
	DN 15	G1 x G1	1-6 l/min	80961	
	DN 15		2-12 l/min	80966	
	DN 15		8-28 l/min	80971	
	DN 15		8-38 l/min	80976	

3-/4-way mixing valves

ARV ProClick

NEW



- For distribution and mixing
- Compact design
- Non-slip rotary knob
- Low torque for increased service life of actuator
- ProClick adapter system for motor mounting without tools



Page 179



Application Universal mixing application in water-based heating and cooling systems (radiators, panel heating systems). The 3-way mixer can also be used as a distribution or zone mixer. Suitable for water and water/glycol mixtures with up to 50 % glycol. Not suitable for drinking water.

Description Compact, low-loss 3-way or 4-way mixing valves with brass base and easy-to-handle rotary knob made of high-strength plastic. The rotary knob with scale allows for easy and accurate manual adjustment of the mixing valve. The elevated mark allows for fast position determination. Two scales with "0 to 10" for horizontal installation and "10 to 0" for vertical installation are included for maximum flexibility.

3-way mixing valve for distribution and mixing: The desired flow temperature is obtained via the precise mixing ratio of hot boiler water and cold water from the return line.

4-way mixing valve for dual mixing. The return temperature to the boiler can be high in order to avoid corrosion damage, for example.

The mixing valves are easy to automate with the AFRISO actuators. The new AFRISO ProClick adapter system allows for hassle-free mounting of the motor to the mixing valve without tools – snap on and done. The low torque ensures a low load on the valves and a long service life.

Technical specifications

Angle of rotation
90°

Operating temperature range
Medium: 5/110 °C

Nominal pressure
Max. 10 bar

Flow rate
See ordering table

Leak rate ($\Delta p = 100 \text{ kPa}$)

DN 25 – DN 32 = Max. 0.2 % Kvs
DN 40 – DN 50 = Max. 0.5 % Kvs

Required torque

DN 20 / DN 25: Max. 0.5 Nm
DN 32: Max. 2 Nm
DN 40 / DN 50: Max. 3 Nm

Material

Housing: Brass (CW617N)
O rings: EPDM

i



Only AFRISO ARM ProClick actuators can be mounted to ARV ProClick valves.

DG: G, PG: 2	DN	Connection	Flow coefficient Kvs	Part no.	Price €
3-way mixing valve ARV 382	20	Rp ¾	6.3 m³/h	78234	
3-way mixing valve ARV 384	25	Rp 1	10 m³/h	78235	
3-way mixing valve ARV 385	32	Rp 1¼	16 m³/h	78236	
3-way mixing valve ARV 386	40	Rp 1½	25 m³/h	78237	
3-way mixing valve ARV 387	50	Rp 2	40 m³/h	78238	
4-way mixing valve ARV 484	25	Rp 1	10 m³/h	78239	
4-way mixing valve ARV 485	32	Rp 1¼	16 m³/h	78241	
4-way mixing valve ARV 486	40	Rp 1½	25 m³/h	78242	
4-way mixing valve ARV 487	50	Rp 2	40 m³/h	78243	

3-way mixing valves ARV ProClick



Housing types and dimensions (mm)

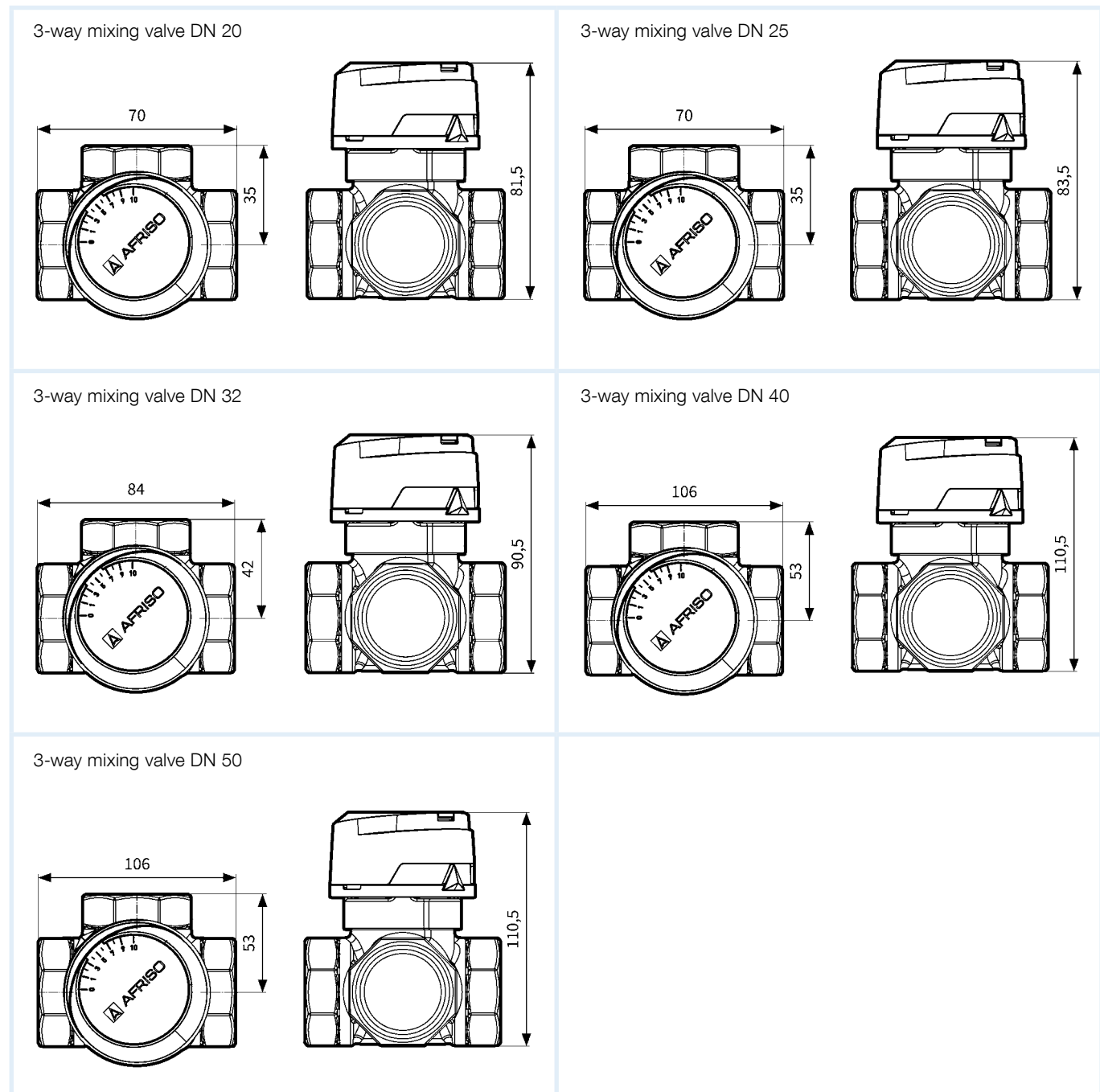

7



4-way mixing valves ARV ProClick

Housing types and dimensions (mm)

4-way mixing valve DN 25

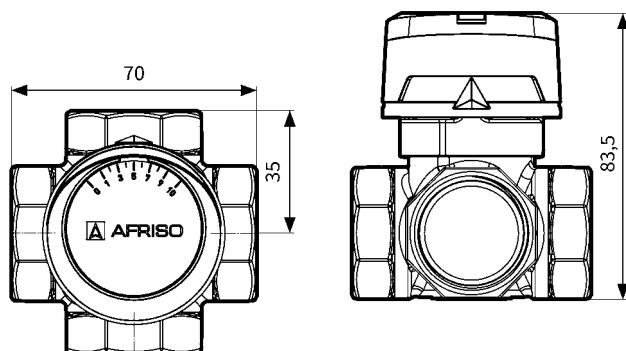

4-way mixing valve DN 32

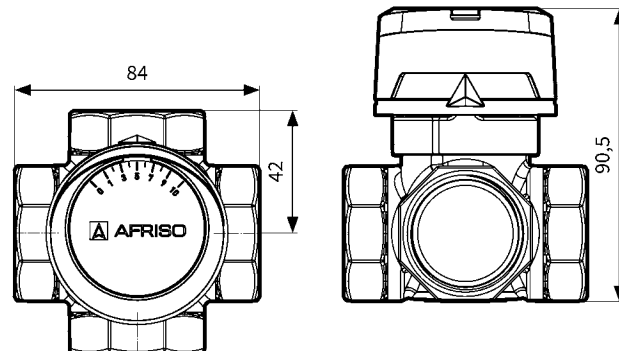

4-way mixing valve DN 40

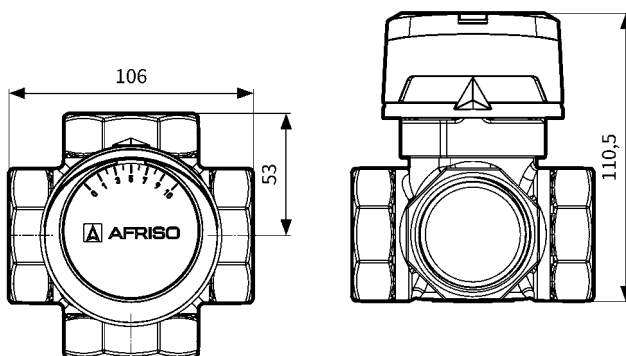

4-way mixing valve DN 50

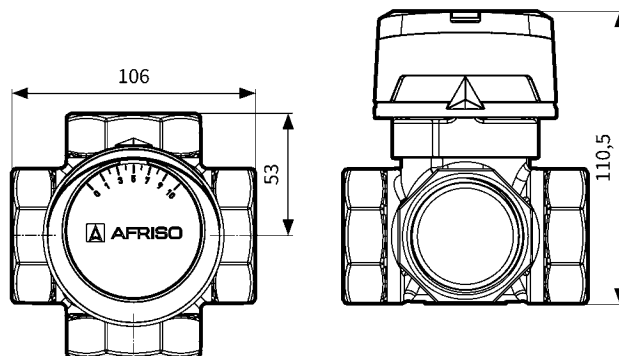

Actuator ARM ProClick



The new silent actuator ARM ProClick is the optimal solution for the automatic control of the return admixture. Thanks to the AFRISO ProClick adapter system, it can be easily mounted to the mixing valve in a matter of seconds: Snap on – done. This simplicity is also available for switching between automatic and manual

mode – it is sufficient to press a button. The new actuator excels with smart features such as integrated protection against blocking of the mixing valve or maintenance-free operation for a long service life.

Mounting in a matter of seconds without tools: Simply snap the actuator onto the mixer, done. Dismounting at the push of a button.

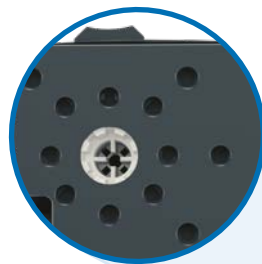

Colour LEDs indicate direction of rotation, ideal for use in darker environments.



7



Simply press a button:
Fast switching between automatic mode and manual mode.

A rotary knob with scale allows for fast and accurate adjustment of the mixing valve.

Full flexibility with regard to mounting direction: The orifice plate features scales on both sides with "0 to 10" or "10 to 0" and can be turned, depending on the direction of flow.

Advantages - your benefits

- Compact, silent actuator with an angle of rotation of 90°
- With ProClick adapter system suitable for AFRISO mixing valves DN 25 and DN 32
- High reliability: An integrated protection unit keeps the actuator and mixing valve from blocking for a long service life

Actuator ARM ProClick

NEW

- **Compact, silent actuator with an angle of rotation of 90°**
- **Mounting without tools: Simply snap the actuator onto the mixer**
- **Colour LEDs indicate direction of rotation**
- **Fast switching between automatic mode and manual adjustment**



Application Can be used for controlling AFRISO series ARV ProClick mixing valves DN 20 to DN 50. Perfect solution for automated operation of water-based heating and cooling systems. Suitable for the AFRISO mixing valve series AVR with ProClick adapter system and for automating the AFRISO pump assemblies 180-2 with nominal diameters DN 25 and DN 32. The new AFRISO ProClick adapter system allows for hassle-free mounting of the motor to the mixing valve without tools – snap on and done.

Description Compact, silent actuator with an angle of rotation of 90° and keys for switching from automatic mode to manual mode. The rotary knob with scale allows for a precise indication of the position in both modes. Three LEDs indicate the direction of rotation of the actuator. The pre-assembled connection cable with colour-coded wires as well as a wiring diagram on the nameplate simplify installation. For full flexibility during mounting, the orifice plate features scales on both sides with "0 to 10" or "10 to 0" and can be turned, depending on the direction of flow. The integrated protection unit keeps the actuator and mixing valve from blocking for a long service life. ARM is maintenance-free.

Technical specifications

Angle of rotation

0/90°

Operating temperature range

Ambient: 0/50 °C

Cable length

2 m

Power input

AC 2.5/4 VA

Housing

Material: Plastic (PC)

W x H x D: 102 x 84 x 89 mm

Protection class: II

Degree of protection: IP 42 (EN 60529)

Input signal

ARM 323, 343, 443: 3-point, digital

ARM 992: 0–10 V, 2–10 V, 0–20 mA, 4–20 mA, PWM

Supply voltage

AC 230 V

ARM 992: AC/DC 24 V

Torque

6 Nm

Term

ARM 323: 60 s

ARM 343, 443: 120 s

ARM 992: 60/120 s

Scope of delivery

Actuator with AFRISO ProClick adapter system

DG: G, PG: 4	Input	Term	Torque	AC/DC	Part no.	Price €
ARM 323 ProClick	3-point	60 s	6 Nm	AC 230 V	77820	
ARM 343 ProClick	3-point	120 s	6 Nm	AC 230 V	77812	
ARM 443 ProClick	3-point	120 s	6 Nm	AC 230 V	77821	
ARM 992 ProClick	0–10 V, 2–10 V, 0–20 mA, 4–20 mA, PWM	60/120 s	6 Nm	AC/DC 24 V	78256	

Boiler manifolds for heating pump assemblies PrimoTherm®



KSV 125-2

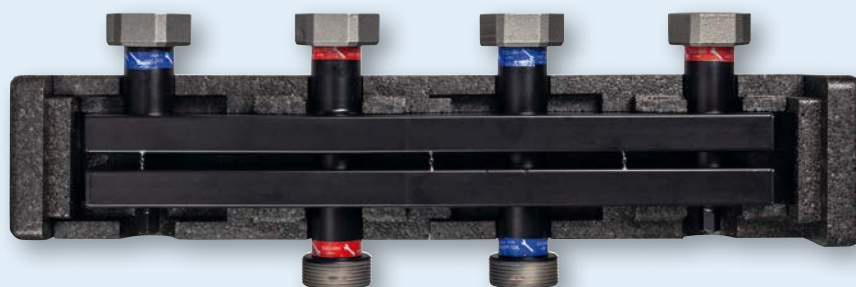

Wall mounting bracket

Application For distribution of the heating circuit water in sealed heating systems as per EN 12828 from the boiler to the heating pump assemblies PrimoTherm®.

KSV 125

Description Boiler manifold as combination flow and return manifold for two, three, four or five heating pump assemblies. Connection to boiler via G1½ threaded sockets, bottom. Connection to heating pump assembly via flat-sealing union nut G1½. AFRISO boiler manifolds are tightness-tested in the factory; they are maintenance-free.

Technical specifications

System connections

Boiler end: Threaded socket G1½ AG
Pump assembly: Union nut G1½, flat-sealing

Axis distance

125 mm

Operating temperature range

Medium: Max. 110 °C

Flow

3.0 m³/h

System pressure

Max. 6 bar

Insulation

Polypropylene EPP

Scope of delivery

Boiler manifold with 2 x wall mounting bracket and insulation

KSV 125 HW

Boiler manifold as combination flow and return manifold for two, three, four or five heating pump assemblies. With integrated hydraulic separator for separation of circuits. Connection to boiler via G1½ threaded sockets, bottom, two connections G½ for drain/temperature probe. Connection to heating pump assembly via flat-sealing union nut G1½.

AFRISO boiler manifolds are tightness-tested in the factory; they are maintenance-free.

System connections

Boiler end: Threaded socket G1½ AG
Pump assembly: Union nut G1½, flat-sealing

Axis distance

125 mm

Operating temperature range

Medium: Max. 110 °C

Flow

3.0 m³/h

System pressure

Max. 6 bar

Insulation

Polypropylene EPP

Scope of delivery

Boiler manifold with 2 x wall mounting bracket and insulation

DG: G, PG: 3	Heating circuits	Hydraulic separator	Part no.	Price €
Boiler manifold KSV 125-2	2	No	77310	
Boiler manifold KSV 125-3	3	No	77311	
Boiler manifold KSV 125-4	4	No	77312	
Boiler manifold KSV 125-5	5	No	77313	
Boiler manifold KSV 125-2 HW	2	Yes	77314	
Boiler manifold KSV 125-3 HW	3	Yes	77315	
Hydraulic separator for KSV 125	-	Yes	77317	

Heating pump assemblies

PrimoTherm® 180 DN 25 KVS Vario

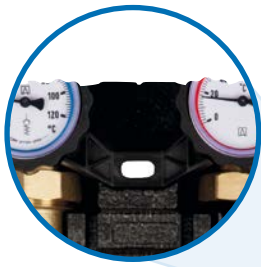

Combination valves with thermometer in the hand wheel, range 0/120 °C. Red/blue mark facilitates the assignment of "supply/return" and function test through the owner/operator of the system. Additional temperature probes (for example, PT 100) can be integrated behind the ball valve.



System connection G1 female for rapid mounting in the heating circuit.

Integrated adjustable gravity brake.

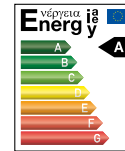
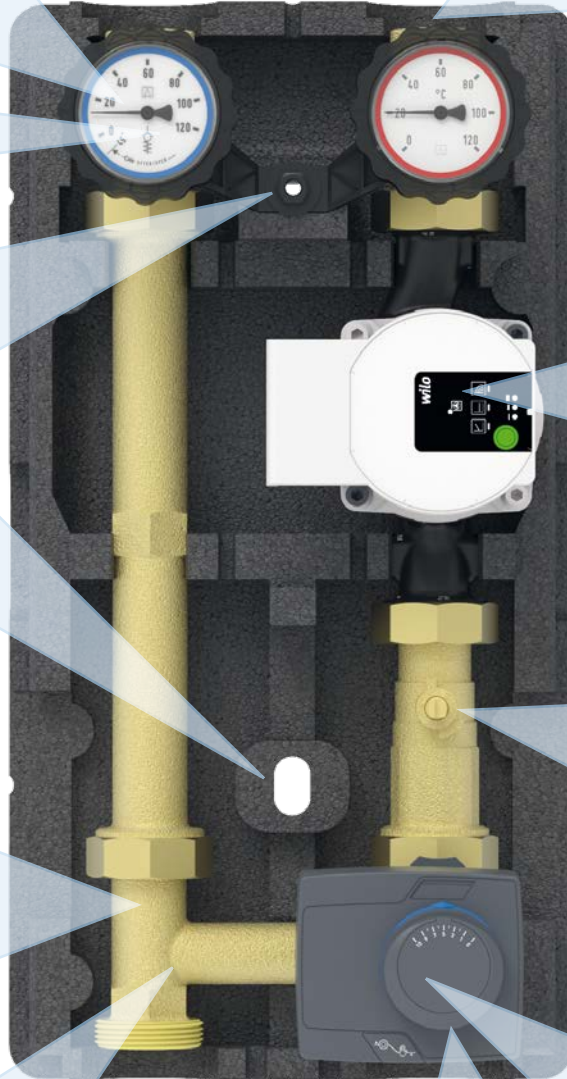

Sophisticated wall mounting kit for easy, fast installation.



Virtually any standard pump can be installed without refitting of the insulation.



Modular system with pump and return line left or right.

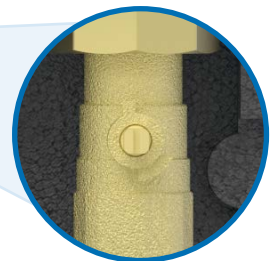

Ball valve below the pump for easy shutting off and increased safety.

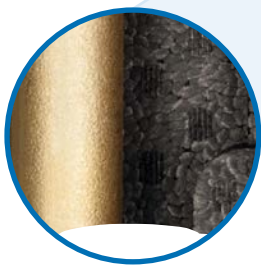

System connection G1½ male for fast mounting to the boiler flow/return by means of flange and union nut. Suitable for KSV.



Snap on – done. New actuator with ProClick adapter system for lightning-fast mounting to the mixer without tools.



High-grade, robust mixer with adjustable flow coefficient Kvs (2,5 to 12) for maximum flexibility all the way to the construction site.

Product highlight:

3-way mixing valve ARV 325 KVS Vario with AFRISO ProClick adapter system



The flow coefficient is key in rating hot water heating systems and providing the right amount of heat at the radiators. Mixing valves in installations must be correctly rated before they are mounted and adjusted to the required flow coefficient Kvs of the system. If a

selection error is made or the system is modified at a later point in time (for example, extended), the existing valve is usually no longer usable. If the flow coefficient Kvs is only estimated, the system will not operate in an efficient way.

Mixer housing made of brass, with robust, glass-fibre reinforced orifice for adjustment of flow coefficient Kvs.

Locking: Integrated locking unit against unintended readjustments.

Easy adjustment of flow coefficient Kvs (initial mounting) with standard slotted screwdriver at the rear of the mixer.

Fast and easy conversion bypass to connection at the right.

Adapter to attach the AFRISO ARM ProClick actuator at the correct position without tools.



Handy, non-slip rotary knob made of high-strength plastic – the scale can be adjusted according to the direction of flow (flow right or left).

Readjustment of flow coefficient Kvs by turning the adjustment handle (no draining of system, unit mounted).

Easy-to-read scale with adjustment values 2.5 – 4 – 5 – 6 – 8 – 12.

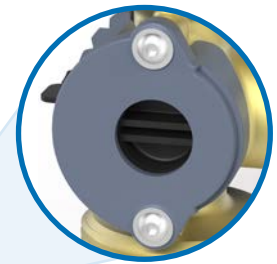
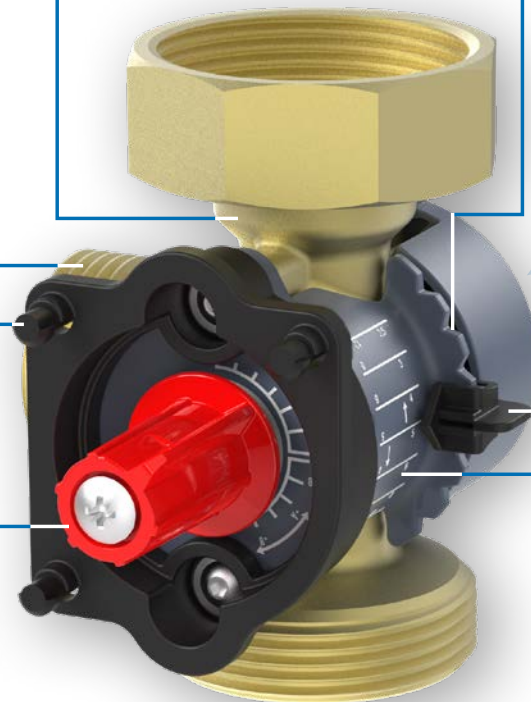

Advantages - your benefits

- **A mixer for all cases:**
Simply set the required flow coefficient Kvs without draining the system
- **No incorrect rating thanks to optimum adaptation to the control requirements of the system.**
This allows for:
 - Smaller volume jump V_{min} / smaller minimum controllable power Q_{min}
 - Higher valve authority PV (pressure ratio between mixer and pipe system with all consumers connected)
 - Complete use of mixer control range (0-100 %)
 - Improved controllability: No cycles, no flow noise
 - Positive effects on hydraulic balancing: Power required to heat the heating surfaces is available and can be used
- **Long-lasting service life:** Low torque for increased service life of actuator
- **Reduces number of versions and warehousing efforts for mixers and pump assemblies**

Overview of versions

Heating pump assemblies PrimoTherm® 180

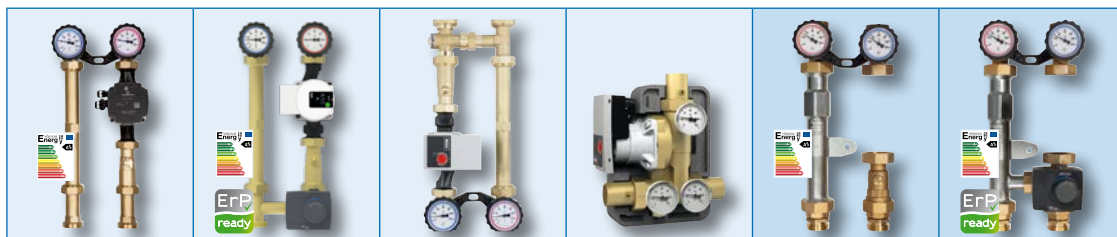

Nominal size	DN 25				DN 32	
Version	180-1	180-2 KVS Vario	180-3	RTA 60	180-1	180-2 KVS Vario
Without circulation pump	•	•	•		•	•
3-way mixer		Flow coefficient Kvs adjustable	Fixed value			Flow coefficient Kvs adjustable
WITH GRUNDFOS UPM3 HYBRID 25-70/180	•	•				
With Wilo Yonos Para 25/6 RKC			•	•		
WILO Para 25-180/6	•	•				
With Wilo stratos Para 30 1-7 r. K.					•	•
Return temperature increase (RTA)		•	•	•		

Description The heating pump assembly PrimoTherm® excels with its versatility and great number of possible combinations. The system assembly for the heating circuit is pre-assembled, tightness-tested, heat-insulated and available in three versions and two sizes, each with or without high energy efficiency pump. All circulation pumps offered by AFRISO meet the requirements of the European Ecodesign Directive (stage 2 as of 2015). The universal insulation allows for the installation of virtually any standard pump without reworking of the insulation. In addition, the system is modular so that the flow line can be mounted at the left or the right side; due to the slim design, it is also possible to mount several pump assemblies next to each other on AFRISO boiler manifolds. In addition, each pump assembly comprises a fastening kit for wall mounting in any position. All PrimoTherm® heating pump assemblies feature a gravity brake to avoid incorrect circulation. The DN -25 versions have the brake in the combination valve; it can be deactivated for servicing. It is also possible to mount temperature probes in the combination valve.



The versions **PrimoTherm® 180-1 DN 25 and 32** are used in non-mixed heating circuits, specially for storage tank charging.



The versions **PrimoTherm® 180-2 DN 25 and 32** are used in mixed heating circuits. With the 3-way mixer and the actuator, the flow temperature can be adjusted to a desired temperature by adding water from the return. PrimoTherm® 180-2 can also be used to increase the return temperature with solid fuel boilers which have a controller for increasing the return temperature. The opening temperature must be set at this controller.



The version **PrimoTherm® 180-3 DN 25** automatically controls the return temperature of the system water to the heat generator to the value adjusted in the valve. The integrated condensation protection valve is the connection between the solid fuel heating system and the heating circuit or the hot water storage tank.

i

We provide a great variety of customer-specific pump assemblies for OEMs. Please enquire.

i

See the operating instructions of the pump assemblies for additional details, www.afriso.com/betriebsanleitungen

Heating pump assembly

PrimoTherm® 180-1 DN 25



- Pre-assembled, tightness-tested and heat-insulated assembly
- Modular system with flow at left or right
- Easy and fast installation
- With high-efficiency pump class A

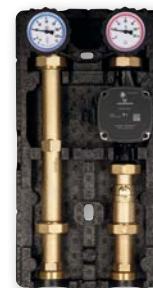
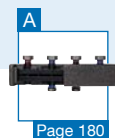

Application Heating pump assembly for use in non-mixed heating circuits, specially for storage tank charging. It connects the heating boiler and the pipe system.

Description Complete, pre-assembled and tightness-tested heating pump assembly with all required functional components, form-fit insulation and wall mounting unit.

7

The pump line (flow/hot) consists of:

- Combination valve with thermometer in the hand wheel (red mark, range 0/120 °C)
 - Ball valve below the pump
 - Pipe for length compensation with screw connection
 - System connection G1½ male (boiler), G1 female (heating circuit)
- Suitable for pumps DN 25 with G1½ x 180 mm.

The return line consists of:

- Combination valve with gravity brake, thermometer in the handle (blue mark, range 0/120 °C)
- Pipe for length compensation (pump/mixer) with screw connection
- System connection G1½ male (boiler), G1 female (heating circuit)

Technical specifications

Axis distance

125 mm

System connections

Boiler G1½ males, heating circuit G1 female

Operating temperature range

Medium: $T_{\max} = 110$ °C

System pressure

Max. 10 bar

Flow coefficient Kvs

4.8 m³/h

Insulation

Polypropylene EPP

Dimensions

W x H x D: 250 x 475 x 152 mm

Options

- Mixer and actuator, can be retrofitted
- Other circulation pumps

Heating pump assembly PrimoTherm® 180-1 DN 25

Dimensions (mm)

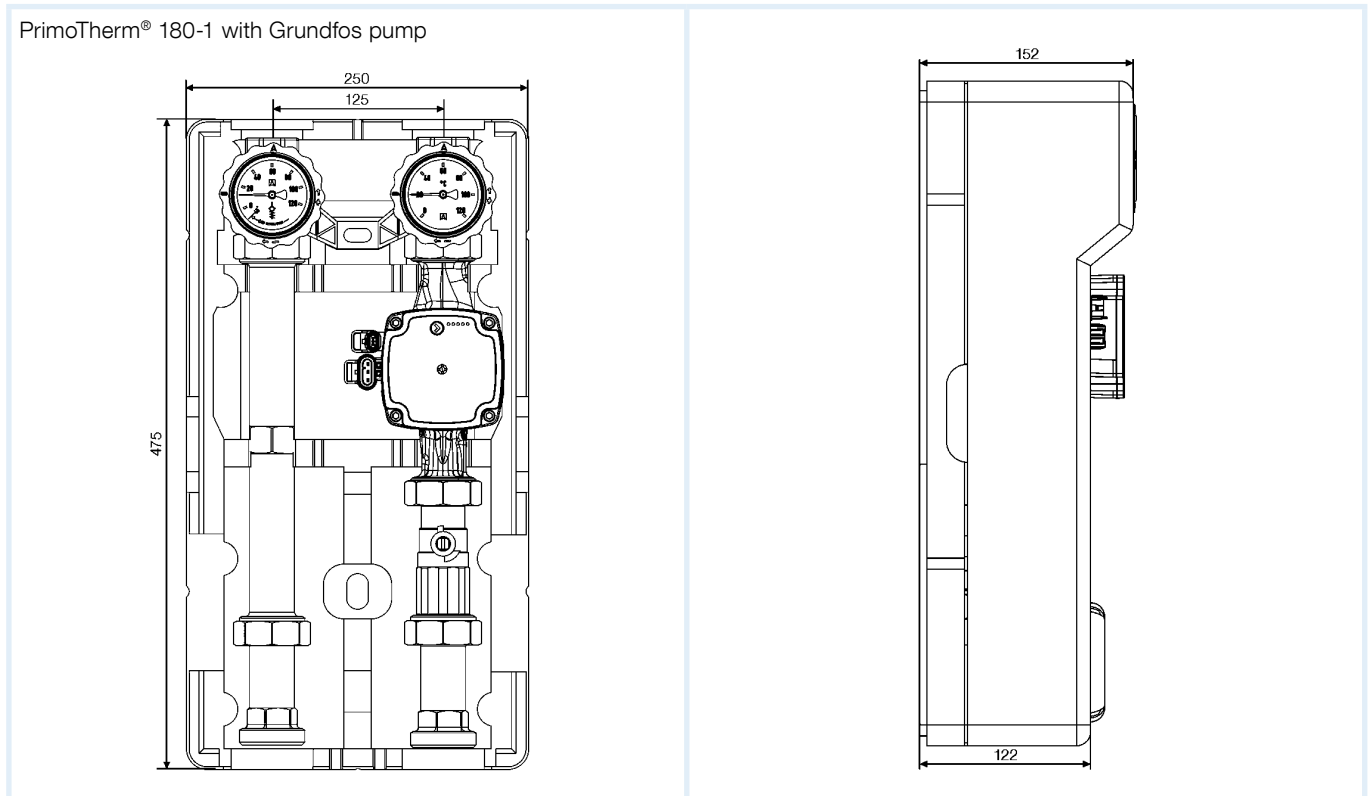

Technical specifications circulation pumps

Length
180 mm

Degree of protection
IP 44

Supply voltage
AC 230 V, 50 Hz

Energy efficiency class
A



	Grundfos	Wilo
Type	UPM3 HYBRID 25-70/180	Para RS 25-180/6
Max. pumping volume	3.6 m ³	3.2 m ³
Max. pump head	7 M	6.7 m
Power input	2–52 W	3–43 W
Operating modes / power levels (Technical specifications pump without guarantee)		
PWM-A	x/4	-/-
PWM-C	x/4	-/-
PP (constant volume flow)	x/3	x/3
CP (constant pressure)	x/3	x/3
CC (constant speed of rotation)	x/3	x/3

DG: G, PG: 2	Pump	Part no.	Price €
PrimoTherm® 180-1 DN 25	Without pump	77643	
PrimoTherm® 180-1 DN 25 WP	Wilo Para RS 25–180/6	77507	
PrimoTherm® 180-1 DN 25 GP	With Grundfos UPM3 HYBRID 25-70/180	77645	
Accessories and spare parts			
	Specification	Part no.	Price €
Connection kit G1½ female x 1 female	2 x connection piece G1 female thread, 2 x union nut G1½ female thread, 2 x flat gasket	77612	
Connection kit G1½ female x 1 female	2 x O ring Ø 28 x 2.5 mm, 2 x reducer G1½, male x 1 male	77613	
3-way mixer KVS Vario with T piece	Axis distance 125 mm	77589	

Heating pump assembly

PrimoTherm® 180-2 DN 25 KVS Vario



- Pre-assembled, tightness-tested and heat-insulated assembly
- Robust mixer with adjustable flow coefficient Kvs from 2.5 to 12 m³/h
- Adaptation of flow coefficient Kvs also possible during operation (under system pressure)

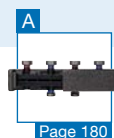

Application

Heating pump assembly for use in mixed heating circuits. With the 3-way mixer and the actuator, the flow temperature can be adjusted to a desired temperature by adding water from the return. The new mixer with adjustable flow coefficient Kvs offers the HVAC professional maximum flexibility in adapting the system to individual control requirements. The flow coefficient Kvs can be modified at any later point in time, even if the system is under pressure. This way, a great variety of mixer/pump assemblies can be covered with a single version. PrimoTherm® 180-2 is also available as version RTA. It can be used to increase the return temperature with solid fuel boilers which have a controller for increasing the return temperature.

Description

Complete, pre-assembled and tightness-tested heating pump assembly with all required functional components, form-fit insulation.

The supply line consists of:

- Combination valve with thermometer in the hand wheel (red mark, range 0/120 °C)
- Ball valve below the pump
- 3-way mixing valve ARV 325 KVS Vario with adjustable flow coefficient Kvs and ProClick adapter system
- Maintenance-free, silent actuator ARM 343 (6 Nm, 120 s, AC 230 V) with 0/90° angle of rotation, indication for direction of rotation, selector key "Manual/Automatic Mode" and ProClick adapter system
- System connection G1½ male (boiler), G1 female (heating circuit)

Suitable for pumps DN 25 with G1½ x 180 mm.

The return line consists of:

- Combination valve with gravity brake, thermometer in the handle (blue mark, range 0/120 °C)
- Pipe for length compensation with screw connection
- T piece for mixer connection
- System connection G1½ male (boiler), G1 female (heating circuit)

Difference version RTA

- Interchanged colour codes of thermometers
- 3-way mixer with flow coefficient Kvs 12 m³/h (not adjustable)
- System connection (storage) with additional connection flanges G1 female
- Additional mounting bracket for upside down or lateral mounting
- Scope of delivery does not include pump

Technical specifications

Axis distance

125 mm

System connections

Boiler G1½ male, heating circuit G1 female

Operating temperature range

Medium: T_{max} = 95 °C, short-term 120 °C

System pressure

Max. 10 bar

Flow coefficient Kvs

Adjustable: 2.5 – 4 – 5 – 6 – 8 – 12 m³/h

Leak rate mixing valve ARV 325 KVS Vario

< 0.05 % flow coefficient Kvs

Insulation

Polypropylene EPP

Dimensions

W x H x D: 250 x 475 x 152 mm



Heating pump assembly

PrimoTherm® 180-2 DN 25 KVS Vario

Dimensions (mm)

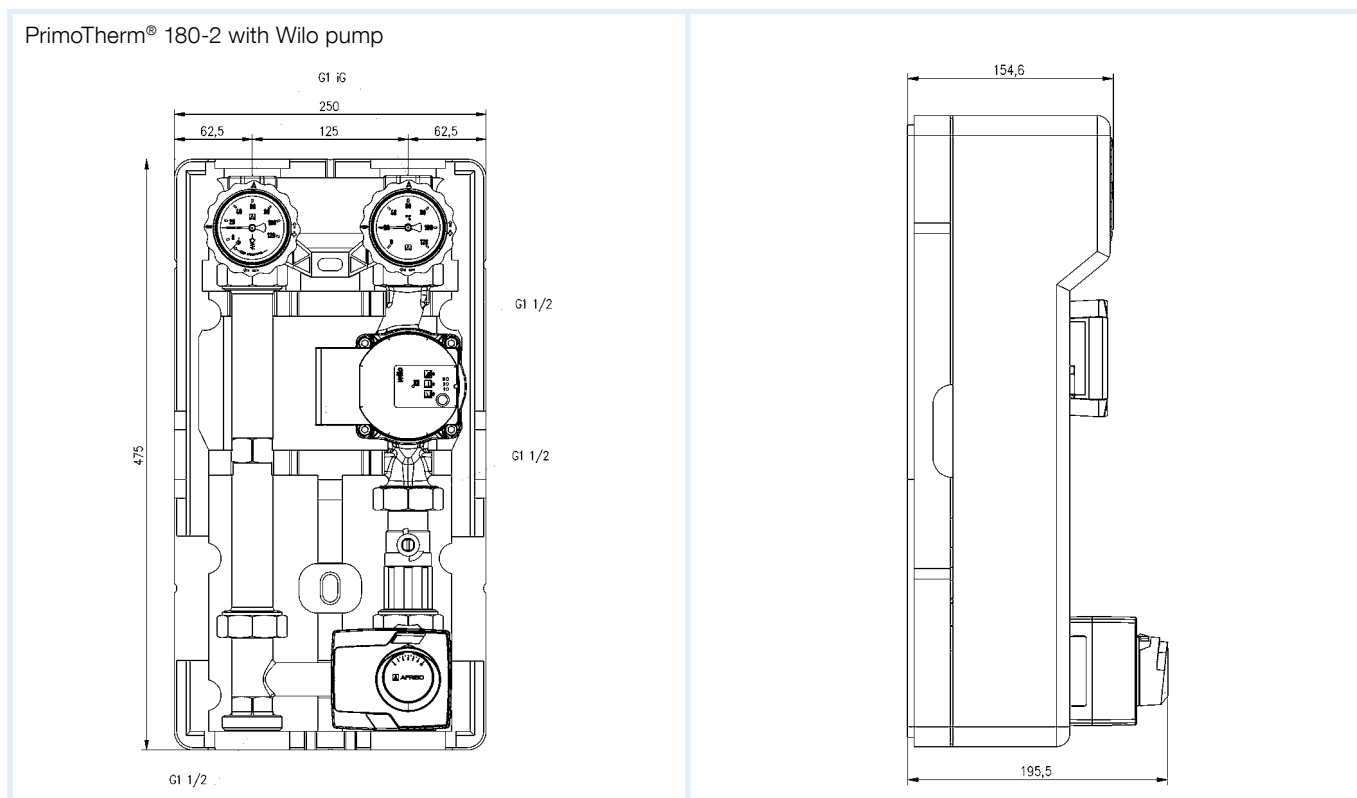

Technical specifications
circulation pumps

Length
180 mm

Degree of protection
IP 44

Supply voltage
AC 230 V, 50 Hz

Energy efficiency class
A



	Grundfos	Wilo
Type	UPM3 HYBRID 25-70/180	Para RS 25-180/6
Max. pumping volume	3.6 m ³	3.2 m ³
Max. pump head	7 M	6.7 m
Power input	2–52 W	3–43 W
Operating modes / power levels (Technical specifications pump without guarantee)		
PWM-A	x/4	-/-
PWM-C	x/4	-/-
PP (constant volume flow)	x/3	x/3
CP (constant pressure)	x/3	x/3
CC (constant speed of rotation)	x/3	x/3

DG: G, PG: 2	Pump	Part no.	Price €
PrimoTherm® 180-2 DN 25 3WM-SM Vario	Without pump	77300	
PrimoTherm® 180-2 DN 25 WP 3WM-SM Vario	With Wilo Para RS 25-180/6	77302	
PrimoTherm® 180-2 DN 25 GP 3WM-SM Vario	With Grundfos UPM3 HYBRID 25-70/180	77301	
Version RTA:			
PrimoTherm® 180-2 RTA DN 25 3WM-SM	Without pump	77304	
Accessories	Specification	Part no.	Price €
Connection kit G1½ female x 1 female	2 x connection piece G1 female thread, 2 x union nut G1½ female thread, 2 x flat gasket	77612	

Heating pump assembly

PrimoTherm® 180-3 DN 25 RTA



- For increased return temperature with solid fuel boilers
- With temperature-controlled condensation protection valve
- For reduced amounts of condensate in the combustion process
- Avoids deposits in the boiler and in the smoke vent



Application Heating pump assembly for automatically controlling the return temperature of the system water to the heat generator to the value adjusted in the valve. An integrated, temperature-controlled condensation protection valve is the connection between the solid fuel heating system and the heating circuit or the hot water storage tank. Using PrimoTherm® 180-3 RTA keeps the temperature in the heating boiler above the condensation point in all operating states. This avoids deposits in the boiler and in the smoke vent and increases the service life of the system; corrosion damage of the heating boiler and chimney fires caused by soot deposits are avoided.

Description Complete, pre-assembled and tightness-tested heating pump assembly with all required functional components, form-fit insulation and wall mounting unit. With an additional mounting bracket, the unit can be mounted in any position (vertically/horizontally).

The pump line (return) consists of:

- Combination valve with thermometer in the hand wheel (blue mark, range 0/120 °C)
 - Ball valve above the pump
 - 3-way mixing valve with fixed mixing temperature 60 °C
 - System connection G1 female (boiler), G1 female (storage)
- Suitable for pumps DN 25 with G1½ x 180 mm.

The flow line (hot) consists of:

- Combination valve with gravity brake, thermometer in the handle (red mark, range 0/120 °C)
- Pipe for length compensation with screw connection
- System connection G1 female (boiler), G1 female (storage)

Function principle

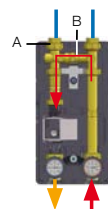

Start mode (heating up of boiler):

When the boiler heats up, the condensation protection valve is fully closed in the direction of the consumer. The liquid coming from the boiler is recirculated in the small circuit via the bypass, which causes the boiler temperature to increase more rapidly.

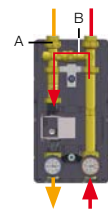

Transition phase:

When the opening temperature is reached (60 °C), the circuit to the consumer is opened proportionally and the bypass is reduced accordingly. However, the boiler temperature will not drop below the set temperature.



Regular operation:

During further operation, the temperature increases until the condensation protection valve is fully open (return storage A). The bypass (B) is closed correspondingly. If the inlet temperature (return storage A) drops to approx 10 °C above the set opening temperature, the admixture via the bypass (B) is increased proportionally and outlet A is closed proportionally.

Heating pump assembly

PrimoTherm® 180-3 DN 25 RTA

Technical specifications

Axis distance
125 mm

System connections
G1 female thread at both ends

Operating temperature range
Medium: T_{max} 100 °C

System pressure
Max. 10 bar

Opening temperatures
60 °C (fixed values)

Technical specifications circulation pump

Wilo Para 25/6 RKC

Length
180 mm

Supply voltage
AC 230 V, 50 Hz

- Options**
- Other opening temperatures
 - Other circulation pumps

Nominal size
DN 25

System capacity
Max. 32 kW at a flow rate of 1,400 l/h and a temperature spread of Δt 20 K

Leak rate
Water-tight between connections A->AB, 3 % leak rate of flow coefficient Kvs between B->AB PN 10. A-AB = Flow coefficient Kvs: 2.94; B-AB = 2.12

Insulation
Polypropylene EPP

Energy efficiency class
A

Power input
3–45 W

Pump head/rate
Max. 6.2 m / max. volume flow 3.3 m³/h

7

Dimensions (mm)

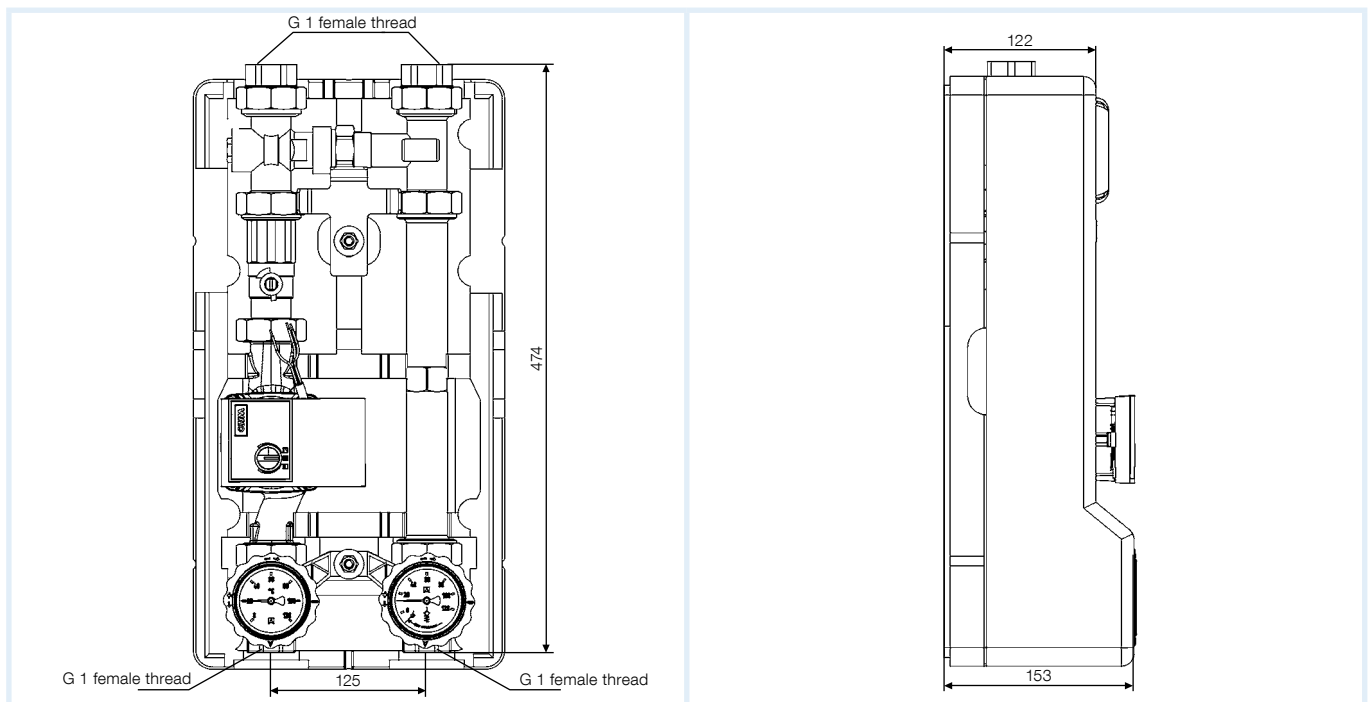

DG: G, PG: 2	Opening temperature	Pump	Part no.	Price €
PrimoTherm® 180-3 DN 25 RTA 60	60 °C	Without pump	77576	
PrimoTherm® 180-3 DN 25 RTA 60 WP	60 °C	Wilo Para RS 25-180-6	77570	

Charging unit RTA 60 DN 25



- For storage tank charging with solid fuel boilers
- Compact unit for limited space conditions
- With temperature-controlled condensation protection valve
- Avoids deposits in the boiler and in the smoke vent



Application Charging unit for direct connection between a solid fuel boiler and a heating system or a hot water storage tank. The compact design allows for mounting to the pipes between the solid fuel boiler and the storage even if space is limited. Using the charging unit RTA 60 DN 25 WP RTA keeps the temperature in the heating boiler above the condensation point in all operating states. This avoids deposits in the boiler and in the smoke vent and increases the efficiency and the service life of the system. The risk of corrosion damage to the boiler and chimney fires resulting from soot deposits is reduced.

Description Complete, pre-assembled and tightness-tested charging unit with all required functional components. The compact insulation contains a central carrier with a high energy efficiency pump. The probe systems of the three thermometers held by the insulation are in the corresponding receptacles of the carrier after mounting. The thermal condensation protection valve and a check valve that can be shut off are contained inside the carrier. Ball valves with connection threads G1 female are screwed to the three system connections.

Function principle Start mode (heating up of boiler)

When the boiler heats up, the condensation protection valve is fully closed in the direction of the consumer. The liquid coming from the boiler is recirculated in the small circuit via the bypass, which causes the boiler temperature to increase more rapidly.

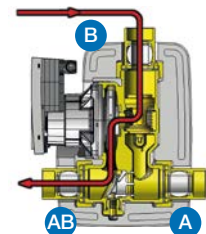

Transition phase

When the opening temperature is reached (60 °C), the circuit to the consumer is opened proportionally and the bypass is reduced accordingly. The boiler temperature increases and heat is provided to the consumer; however, the return temperature will not fall below the set temperature.

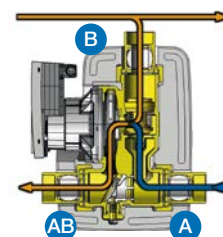

Regular operation

During further operation, the temperature increases until the condensation protection valve is fully open (return storage A). The bypass (B) is closed correspondingly. If the inlet temperature (return storage A) drops to approx 10 °C above the set opening temperature (e.g. 65 °C), the admixture via the bypass (B) is increased proportionally and outlet A is closed proportionally.

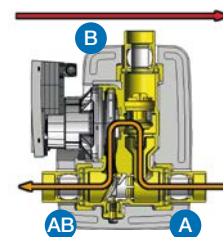

Charging unit RTA 60 DN 25

Technical specifications

System connections

G1 female thread

Operating temperature range

Medium: T_{max} 100 °C

System pressure

Max. 6 bar

System capacity

Max. 60 kW at a flow rate of 2,600 l/h and a temperature spread of Δt 20 K

Insulation

Polypropylene EPP

Dimensions (mm)

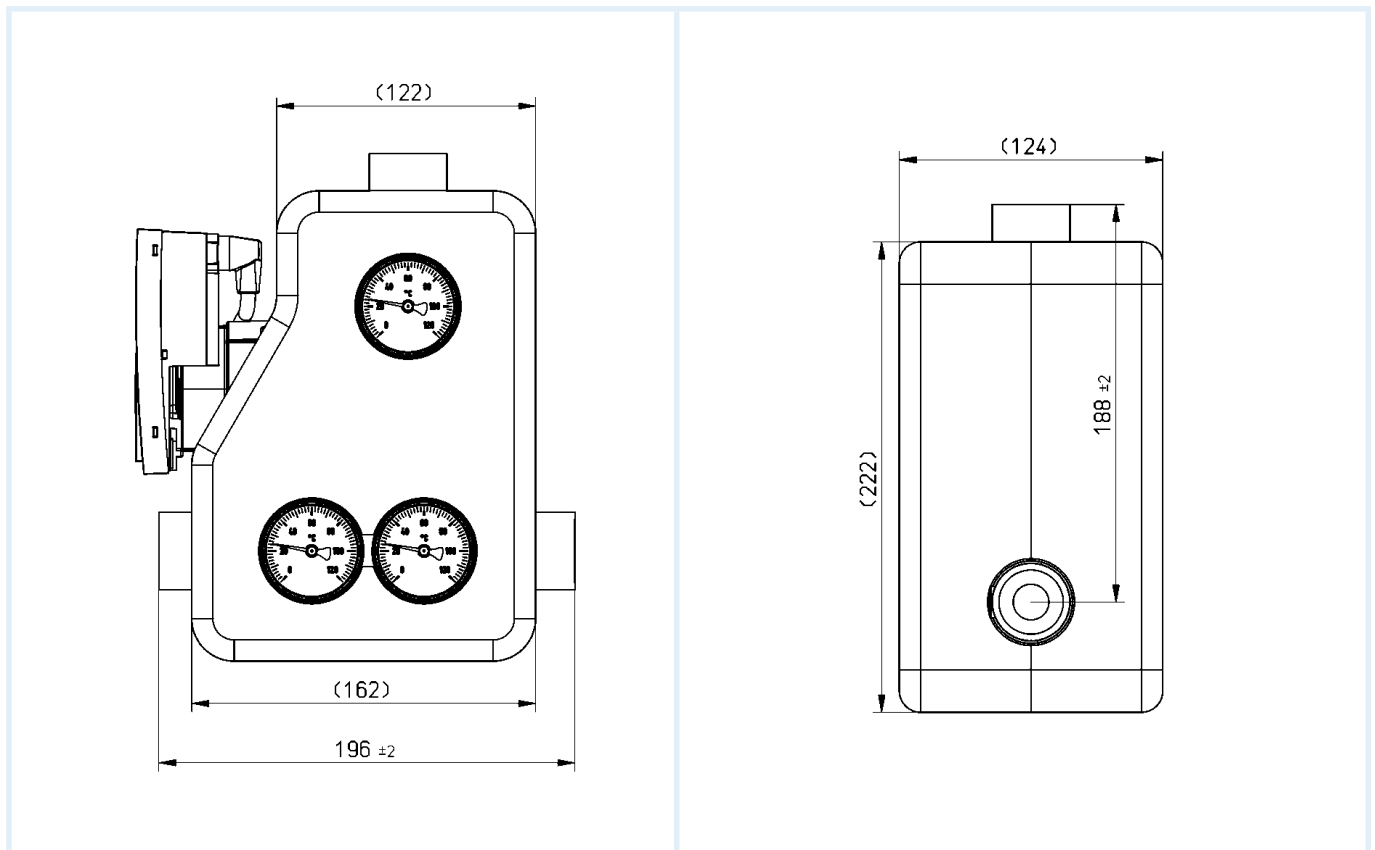

7

DG: G, PG: 2	Opening temperature	Pump	Part no.	Price €
Charging unit RTA 60 DN 25 WP	60 °C	Wilo Yonos Para RS/7.5-RKC	77548	

Heating pump assembly

PrimoTherm® K 180-1 DN 32



- Pre-assembled, tightness-tested and heat-insulated assembly
- Compact design
- Available with high energy efficiency pump class A
- Easy and fast installation



Application Heating pump assembly for use in non-mixed heating circuits, specially for storage tank charging. It connects the heating boiler and the pipe system.

Description Complete, pre-assembled and tightness-tested heating pump assembly with all required functional components, form-fit insulation and wall mounting unit.
System connection: Primary end (consumer) G1¼ female

The pump line (flow/hot) consists of:

- Combination valve with thermometer in the hand wheel (red mark, range 0/120 °C)
- Ball valve below the pump, suitable for use of pumps with 2" x 180 mm
- System connection G1¼ female (heating circuit)

The return line consists of:

- Combination valve with thermometer in the hand wheel (blue mark, range 0/120 °C)
- Pipe for length compensation with gravity brake
- System connection (boiler) G2 with screw connection G1¼ female (easy mounting and adapter G1½ AB for use with boiler manifold)

Technical specifications

Axis distance

125 mm

System connections

Boiler G1¼ female
Heating circuit G1¼ female

Operating temperature range

Medium: T_{max} 110 °C

System pressure

Max. 10 bar (observe maximum pressure of circulation pumps used)

Supply voltage

AC 230 V, 50 Hz

Nominal size

DN 32

Flow coefficient Kvs

21.0 m³/h

Insulation

Polypropylene EPP

- Options**
- With high-efficiency pump EEI 0,2

DG: G, PG: 2	Part no.	Price €
PrimoTherm® K 180-1 DN 32	79501	



Heating pump assembly PrimoTherm® K 180-1 DN 32

Dimensions (mm)

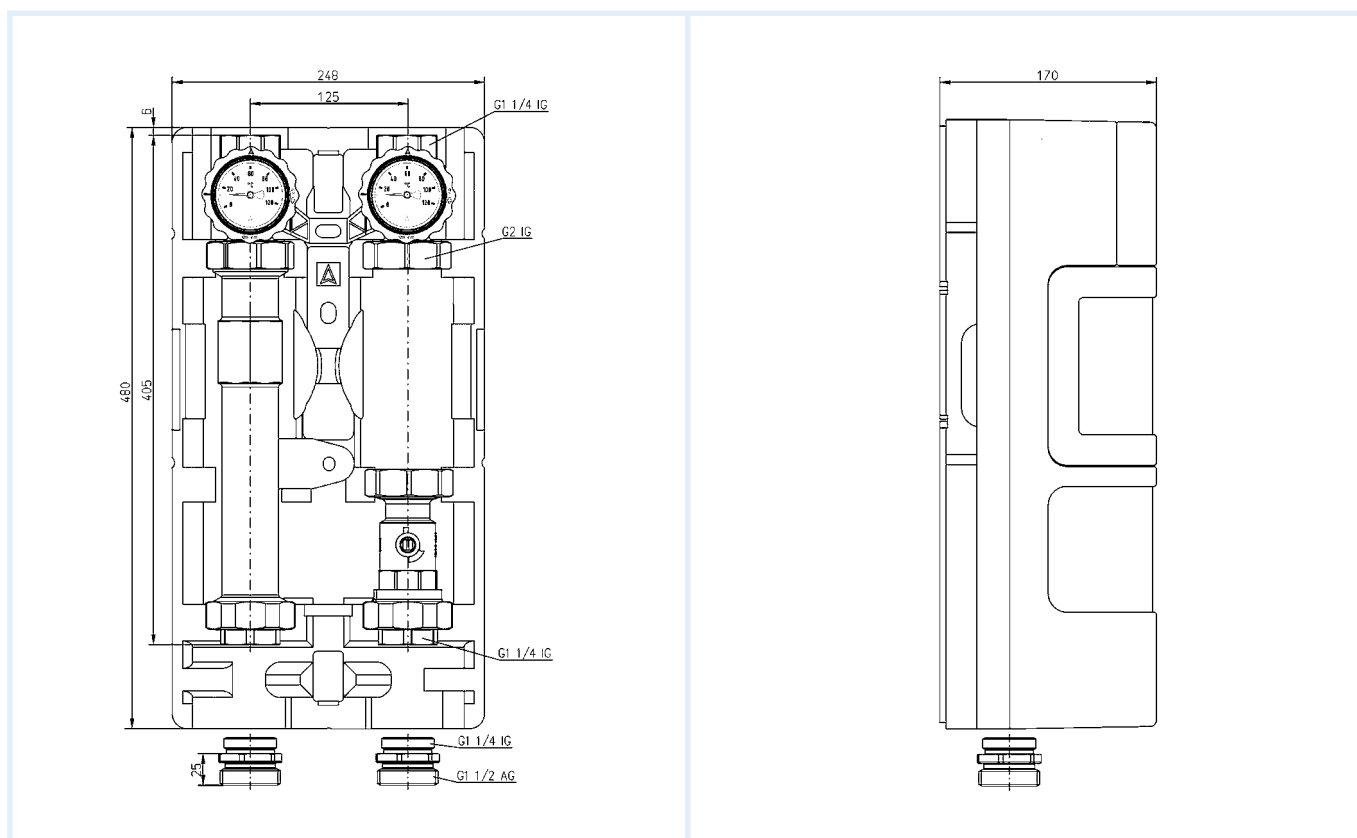

Heating pump assembly

PrimoTherm® K 180-2 DN 32 KVS Vario

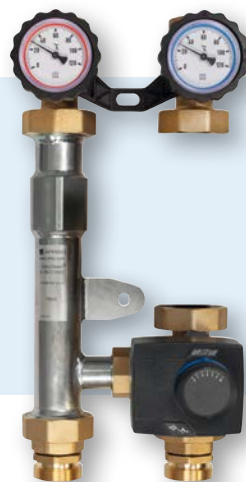

- Pre-assembled, tightness-tested and heat-insulated assembly
- Compact design
- Robust mixer with adjustable flow coefficient Kvs from 12 to 22 m³/h
- Available with high energy efficiency pumps class A and high-grade, robust mixer as well as actuator
- Easy and fast installation



Application Heating pump assembly for use in non-mixed heating circuits. It connects the heating boiler and the pipe system. With the 3-way mixer KVS Vario and the actuator, the flow temperature can be adjusted to a desired temperature by adding water from the return. PrimoTherm® 180-2 can also be used to increase the return temperature with solid fuel boilers which have a controller for increasing the return temperature. The opening temperature must be set at this controller.

Description Complete, pre-assembled and tightness-tested heating pump assembly with all required functional components, form-fit insulation and wall mounting unit.

The flow line consists of:

- Combination valve with thermometer in the hand wheel (red mark, range 0/120 °C)
 - 3-way mixing valve ARV 325 KVS Vario with adjustable flow coefficient Kvs and ProClick adapter system
 - Maintenance-free, silent actuator ARM 343 (6 Nm, 120 s, AC 230 V) with 0/90° angle of rotation, indication for direction of rotation, selector key "Manual/Automatic Mode" and ProClick adapter system
 - System connection G1¼ female (heating circuit)
- Suitable for pumps with 2" x 180 mm.

The return line consists of:

- Combination valve with thermometer in the handle (blue mark, range 0/120 °C), pipe for length compensation with gravity brake
- System connection (boiler) G2 with screw connection G1¼ female (easy mounting and adapter G1½ AB for use with boiler manifold)

Technical specifications

Axis distance

125 mm

System connections

Boiler G1¼ female
Heating circuit G1¼ female

Operating temperature range

Medium: T_{max} 110 °C

System pressure

Max. 10 bar (observe maximum pressure of circulation pumps used)

Flow coefficient Kvs

Adjustable: 12 – 16 – 22 m³/h

Leak rate mixing valve ARV 325 KVS Vario

< 0.05 % flow coefficient Kvs

Insulation

Polypropylene EPP

Dimensions

W x H x D: 248 x 480 x 170 mm

- Options**
- High-efficiency pump
Wilo Stratos Para 30 1-7 r. K.
 - Other circulation pumps

DG: G, PG: 2	Pump	Part no.	Price €
PrimoTherm® K 180-2 DN 32 3WM-SM Vario	Without pump	79502	



Heating pump assembly PrimoTherm® K 180-2 DN 32 KVS Vario

Dimensions (mm)

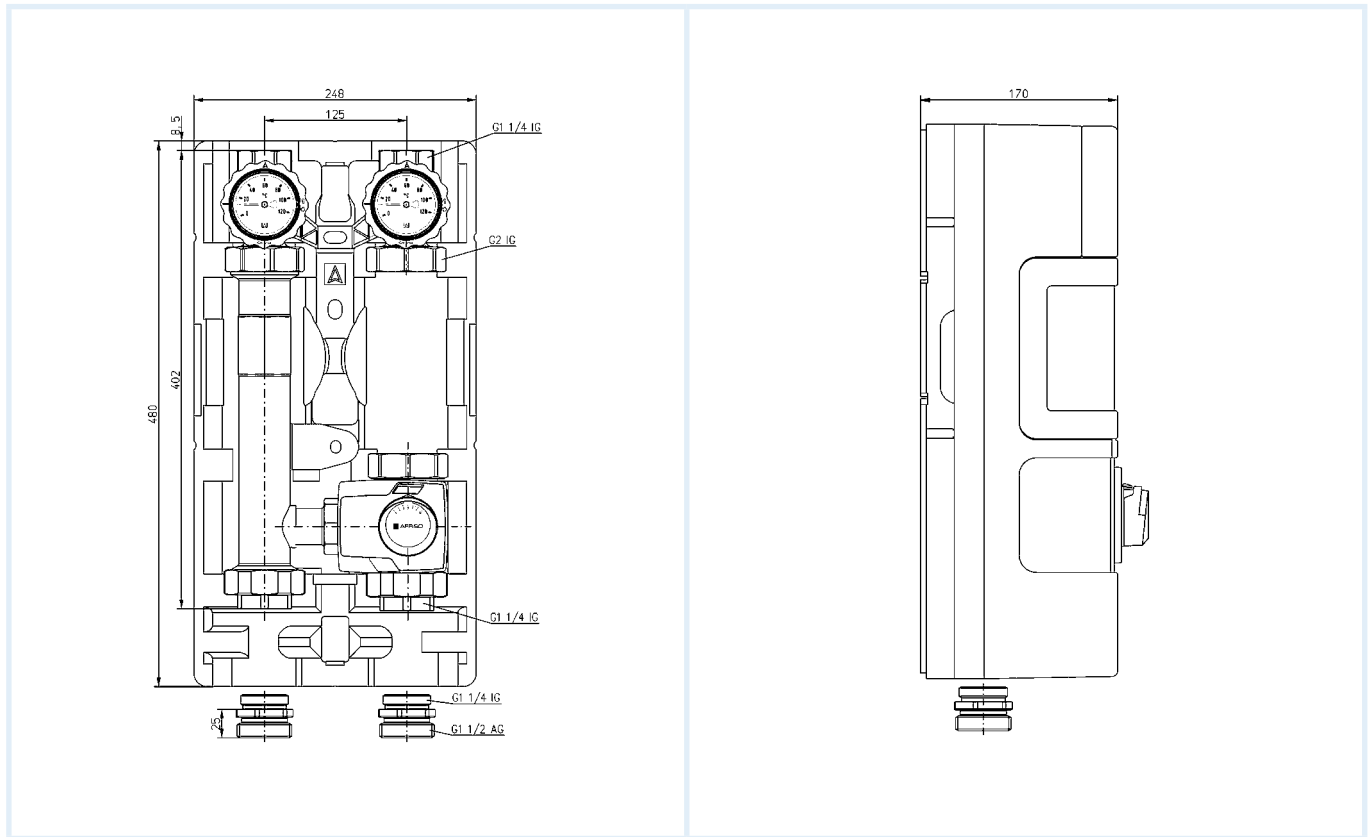

Solar pump assemblies

PrimoSol®



- 1 Solar pump assembly PrimoSol® 130-4
- 2 Collector tank for solar liquid
- 3 Air separator combination Solar LKS

7

Efficient solar thermal systems are taking centre stage in heating system design as a result of rising energy costs, new legislation and, most important, increasing environmental awareness. Advanced solar thermal systems can be easily integrated into the heating system concepts for new buildings and for the conversion of existing systems.

i

We provide a great variety of customer-specific solar pump assemblies for OEMs.

Please enquire.

AFRISO offers a comprehensive range of components for solar thermal systems for maximum reliability – all from a single supplier. The innovative solar pump assemblies PrimoSol® are made to meet the requirements of the solar systems available on the market.

The pre-assembled, tightness-tested and heat-insulated assemblies are extremely easy and fast to install. The offer is complemented by a comprehensive range of accessories.

Solar pump assembly

PrimoSol® 130



- Pre-assembled, tightness-tested and heat-insulated assembly
- Available with flow meter with ball valve, integrated filling and flushing unit and vent pot for degassing the heat transfer fluid in the flow line



Application Solar pump assembly/line for connection of collector and storage tank in intrinsically safe, sealed solar thermal systems. PrimoSol® 130 circulates heat transfer fluids such as water/glycol mixtures in the system.

Description Complete, pre-assembled and tightness-tested solar pump assembly/line with all required safety and functional components, including form-fit insulation.

Depending on the version, the pump line (return/cold) consists of:

- Circulation pump
- Flow meter with ball valve for shut-off, pump end with flange and union nut G1½. Measuring range: 2–12 l/min. With integrated filling and flushing unit, system connection: G¾ male thread.
- Combination valve with system connection G¾ male thread, pump end with flange and union nut G1½. With adjustable gravity brake and thermometer in the hand wheel (blue mark, range 0/120 °C).
- Safety group assembly with connection for expansion vessel. With solar safety valve 6 bar, outlet Rp¾ female thread, pressure gauge Ø 63 mm, 0/10 bar, mounting valve.

The flow line consists of (130-4 only):

- Combination valve with adjustable gravity brake and thermometer in the handle (red mark, range 0/120 °C) with system connection G¾
- Vent pot to remove the gas from the heat transfer fluid with system connection G¾. Transparent hose 200 mm as venting aid.

The insulation is also used to package the product for protected transport.

The safety valve of the safety group assembly complies with Pressure Equipment Directive 2014/68/EC.

Technical specifications

Axis distance

100 mm

System connection

G¾ male thread

Operating temperature range

Ambient: $T_{max} = 40\text{ °C}$

Medium: $T_{max} = 120\text{ °C}$,
short-term $T_{max} = 160\text{ °C}$

System pressure

Max. 6 bar

Flow meter

2–12 l/min

Insulation

Polypropylene EPP

Circulation pump

Grundfos UPM 3 Solar 25–75

Length: 130 mm

Degree of protection: IP 42

Supply voltage

AC 230 V, 50 Hz

Power input/pumping head

19 W/4.5 m

28 W/5.5 m

35 W/6.5 m

45 W/7.5 m

DG: G, PG: 2	Part no.	Price €
PrimoSol® 130-1, 2-12 l/min	77886	
PrimoSol® 130-4, 2-12 l/min	77889	
PrimoSol® 130-4, 8-38 l/min	77018	
PWM cable, length 1 m suitable for PrimoSol GP	77015	

Solar pump assembly PrimoSol® 130



Dimensions (mm)

Solar pump line PrimoSol® 130-1

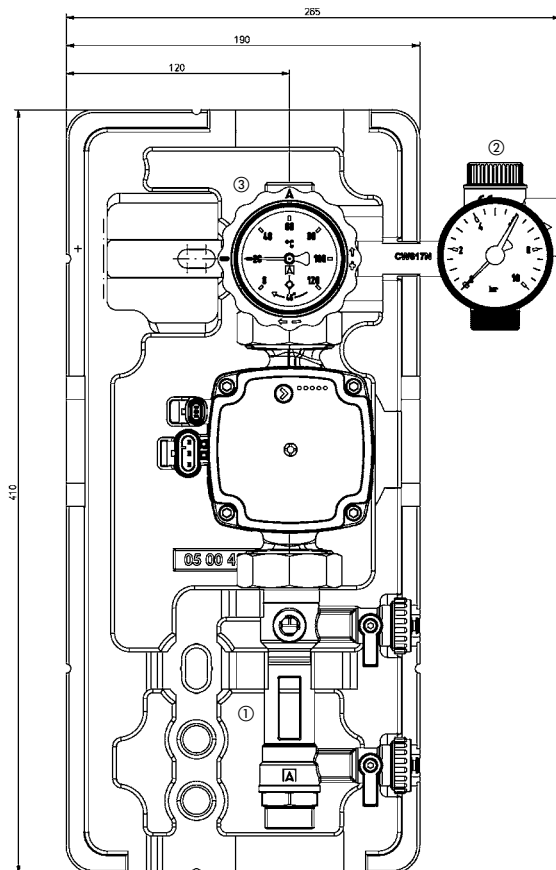

- ① Flow meter with ball valve as well as filling and flushing unit
- ② Safety group assembly
- ③ Combination valve with thermometer (return/cold)

Solar pump assembly PrimoSol® 130-4

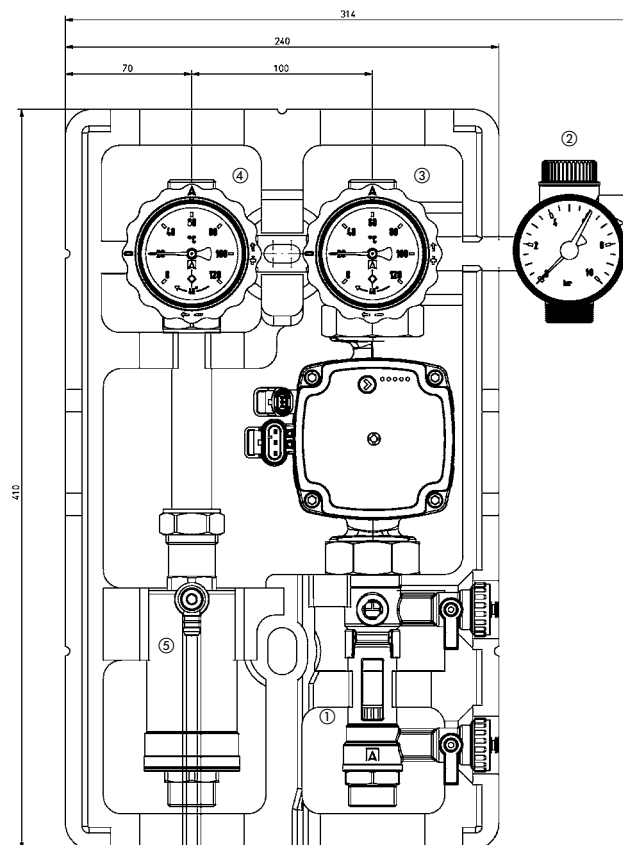

- ① Flow meter with ball valve as well as filling and flushing unit
- ② Safety group assembly
- ③ Combination valve with thermometer (return/cold)
- ④ Combination valve with thermometer (flow)
- ⑤ Vent pot for fast and easy venting, especially during filling of the system

Insulation 130-1 and 130-4

The insulation is also used to package the product for transportation.

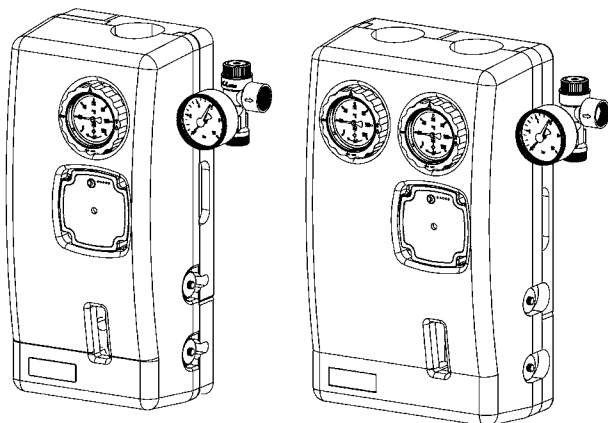

Scope of delivery

PrimoSol® completely pre-assembled with circulation pump and mounting accessories.

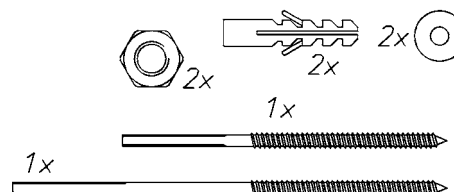

Accessories for solar thermal systems



Filling and flushing unit

Description For solar systems as filling and flushing unit. With ball valve, two boiler filling and drain valves KFE G $\frac{3}{4}$, process connection G1 with union nut and compression fittings at both ends.

Technical specifications

Connections G1, compression fitting at both ends \varnothing 22 mm

Dimensions
L: 108 mm

Housing
Brass



Diaphragm safety valve MSS

For solar thermal systems to protect against overpressure. Suitable for water, water/Antifrogen mixtures, water/Tyfocon mixtures and liquids of fluid groups 1 and 2 (Pressure Equipment Directive, Art. 9).

Connections
Inlet: G $\frac{1}{2}$ female
Outlet: G $\frac{3}{4}$ male

Cap
PA6, black

Opening pressure
6 bar

Dimensions
W x H x D: 35 x 60 x 45 mm

Housing
Brass CW617 N

Operating temperature range
Medium: -20/+160 °C

Heating capacity
Max. 50 kW

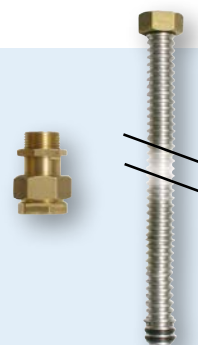

Connection kit

For diaphragm expansion vessels (MAG) suitable for safety group assembly for PrimoSol®.

Consisting of:

- Bracket for wall mounting
- Flex pipe (500 mm, 1 union nut and seals)
- MAG mounting valve
- Mounting accessories

Connections
Flex pipe: Union nut G $\frac{3}{4}$
Mounting valve: G $\frac{3}{4}$

Dimensions
Flex pipe (L): 500 mm
Bracket (W x L): 220 x 110 mm

7



Please enquire for diaphragm safety valves with other pressure ratings.

DG: G, PG: 2			Part no.	Price €
Filling and flushing unit	1	1	77781	
Diaphragm safety valve MSS, G$\frac{1}{2}$ female x G$\frac{3}{4}$ female	1	84	42330	
Connection kit G$\frac{3}{4}$	1	1	77904	

Vents for solar thermal systems



Quick air vents for solar systems

Description Quick air vent for use in solar thermal systems with operating temperatures of up to 150 °C and operating pressures of up to 6 bar. Housing made of high-precision turned brass, functional parts made of highly temperature-resistant plastic. Connection G^{3/8} with O ring seal.



Quick air vents for solar systems with ball valve

Quick air vent for use in solar thermal systems with operating temperatures of up to 150 °C and operating pressures of up to 6 bar. Housing made of high-precision turned brass, functional parts made of highly temperature-resistant plastic. Completely assembled with ball valve as shut-off unit. Connection G^{3/8}.



Air separator

Air separator for use in solar thermal systems or in sealed heating systems as per EN 12828 with operating temperatures of up to 150 °C and operating pressures of up to 6 bar. The air separator removes the air from the heat transfer fluid. The air collects in the housing and can be released via a quick air vent or a manual vent valve connected at the G^{3/8} threaded connection. Compression fitting for Cu pipe Ø 22 mm at both ends.

DG: G, PG: 2	Connection			Part no.	Price €
Quick air vents for solar systems	G ^{3/8}	1	25	77900	
Quick air vents for solar systems with ball valve	G ^{3/8}	1	25	77996	
Air separator	Compression fitting Ø 22	1	-	77851	

Air separator combination Solar LKS, collector tank for solar liquid



Air separator combination Solar LKS

Application For use in thermal solar systems to remove air bubbles from the solar liquid.

Description Air separator, completely pre-assembled with quick air vent for solar systems. The air separator removes the air contained in the heat transfer medium. The air collects in the housing and can be released via the quick air vent for solar systems connected at the G^{3/8} connection by actuating the ball valve.

Technical specifications **Operating temperature range**
Medium: Max. 150 °C

System pressure
Max. 6 bar

System connections
Compression fitting for Cu pipe
Ø 22 mm at both ends



Collector tank for solar liquid

Collects groundwater polluting solar liquid in the case of system overpressure.

Collector tank for solar liquid with integrated drain valve. Volume 10 l. The collector tank for solar liquid is connected to the diaphragm safety valve MSS or to the safety group assembly PrimoSol® of the solar pump assembly via a pipe. In the case of system overpressure, it collects escaping solar liquid. A basic volume of 1 to 1.5 l of liquid is always contained in the collector tank to avoid overheating of the collector tank if solar liquid escapes suddenly from the solar thermal system.

Operating temperature range
Medium: Max. 95 °C
short-term 120 °C
(without basic liquid volume)

Dimensions
W x H x D: 300 x 390 x 145 mm

Weight
0.97 kg

Filling volume
Max. 10 l

Solar pump assembly
PrimoSol® 130-4 with
collector tank for solar
liquid in a solar thermal
system

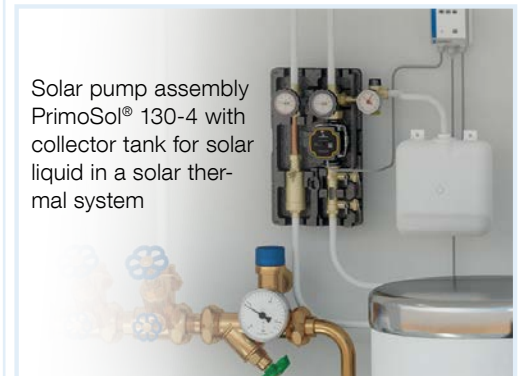

DG: G	PG			Part no.	Price €
Air separator combination Solar LKS, Connection: Compression fitting Ø 22	1	1	1	77850	
Collector tank for solar liquid	1	1	1	77796	

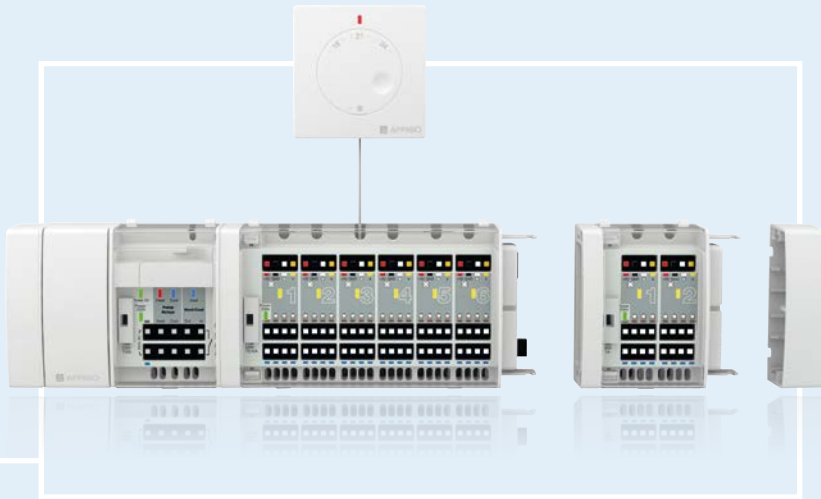

Single room temperature controllers



Terminal blocks for controllers



Manifold systems for heating and cooling

CHAPTER 8

Equipment for surface heating and cooling systems

SINGLE ROOM CONTROLLER	
Overview single room temperature controller CosiTherm®	204
Single room temperature controller CosiTherm® – wireless	206
Room temperature sensor D – wired	209
Single room temperature controller CosiTherm® – wireless	210
Room temperature sensor FT – wireless	213
Single room temperature controller FloorControl controller terminal bar WB 01 – wireless	214
Room thermostat TA 03 for controller terminal bar WB 01	216
Room thermostat RT 01 for controller terminal bar WB 01	218
Room thermostat RT 05 for controller terminal bar WB 01	219
Thermostatic actuators TSA-02	220
Thermostatic actuators TSA-02 FO with First-Open function	221
Thermostatic actuator TSA-03	222
MECHANICAL SINGLE ROOM CONTROLLER	
Single room controller RTL-Box 324 Vario	223
MANIFOLDS	
Stainless steel heating circuit manifold ProCalida® VA 1C Vario-DP with dynamic control valve	225
Pump assembly PrimoTherm® Floor 130	231
OEM manifold systems: Heating circuit manifold ProCalida® MC, EF	234
Heating circuit/geothermal manifold ProCalida® IN 1½, GT , drinking water manifold	235

Single room temperature controller CosiTherm®

Overview wired version



Base module with controller module for 6 control circuits



Base module with timer module and controller module for 8 control circuits



Base module with timer module and controller module for 12 control circuits



Room temperature sensor wired

Functions

- Adjustment of reference temperature 6/30°C
- Measurement of actual temperature

8

i

The controller modules can be combined as required, subject to the conditions on site.

Overview wireless version



Base module with controller module for 6 control circuits



Base module with timer module and controller module for 8 control circuits



Base module with timer module and controller module for 12 control circuits



reddot award 2014
winner



enocean®



Room temperature sensor wireless

Functions

- Adjustment of reference temperature 6/30°C
- Measurement of actual temperature

Functions and connections

Single room temperature controller CosiTherm®

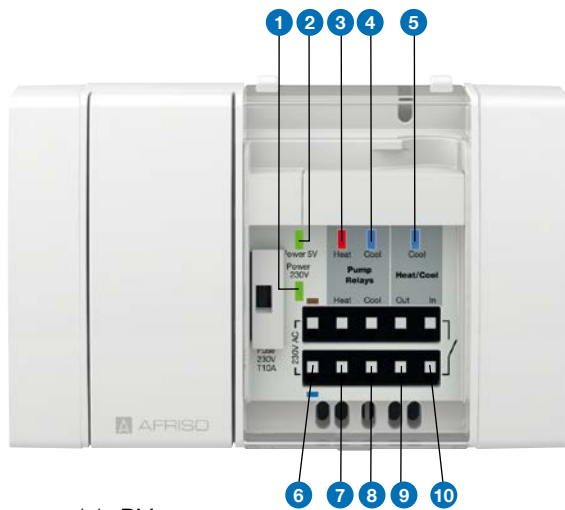

Base module BM

Base module BM

- 1 LED green: Operation mains voltage
- 2 LED green: Operation DC 5 V
- 3 LED red: Pump "Heating"
- 4 LED blue: Pump "Cooling"
- 5 LED blue: Indication program mode "Heating" or "Cooling"
- 6 Connection supply voltage AC 230 V
- 7 Relay contact pump "Heating"
- 8 Relay contact pump "cooling"
- 9 Cascading output "Heating/Cooling"
- 10 Input switchover "Heating/Cooling"

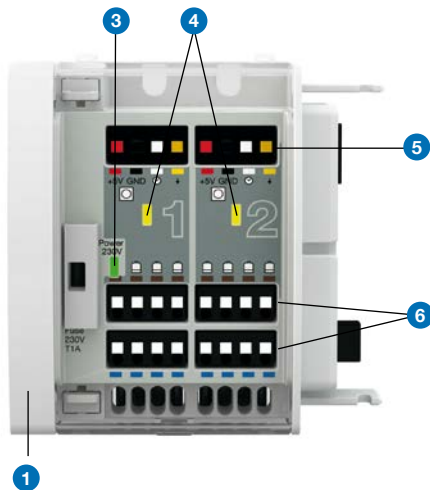

Controller module D2

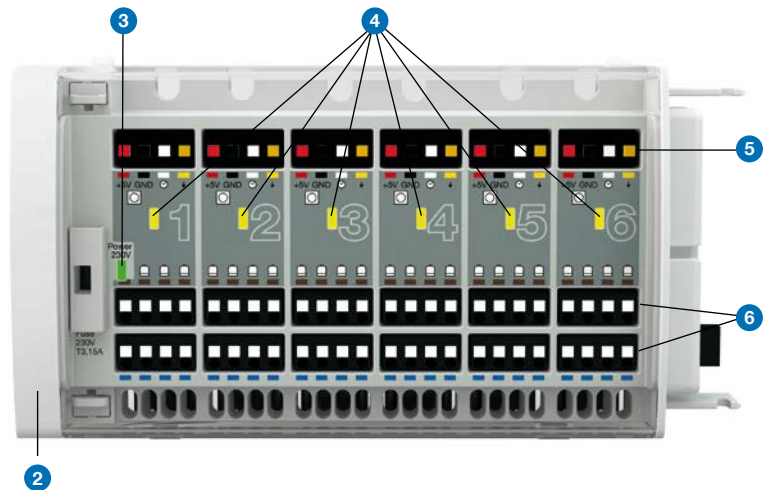

Controller module D6

Controller module wired

- 1 Controller module with two control circuits
- 2 Controller module with six control circuits
- 3 LED green: Indication mains voltage for thermostatic actuators
- 4 LED yellow: Indication thermostatic actuator active
- 5 Terminal block for room temperature sensors
- 6 Terminal block for thermostatic actuators

Single room temperature controller CosiTherm® – wired



- Controller terminal bar for connection of actuators
- For manifold systems for heating and cooling
- Extremely flat room temperature sensor with a height of 12.5 mm
- Room temperature sensor with wire connection
- Timer module for programming temperature reduction, pump operating time and valve protection function

Application Controls the temperature of individual rooms in connection with manifold systems for heating and cooling.

Description The base version of the single room temperature controller CosiTherm® wired consists of a base module, at least one controller module with two or six independent control circuits and a corresponding number of room temperature sensors. The controller modules can be interconnected in a modular way to account for the number of control circuits/rooms. One room temperature sensor is required per control circuit; it is wired to the controller module. The room temperature sensor measures the actual temperature in the room. The reference temperature is adjusted via the rotary knob of the room temperature sensor. The controller module compares the actual temperature and the reference temperature and controls the volume flow of the heating/cooling water via the thermostatic actuators of the manifold system.

An optional timer module with display and an integrated hundred-year calendar can be plugged into the base module. It features two independently programmable switching channels for temperature reduction, nine programmable memory blocks and a valve and pump protection function. The additional pump running time is adjustable. The terminals of the controller modules are colour-coded for easy assignment to the wires; in conjunction with the DIN rail snap connectors at the rear of the housing, this facilitates installation.

Functions Base module BM

- Power supply of the room temperature sensors (DC 5 V) and thermostatic actuators (AC 230 V)
- Switchover of the system to "Heating" or "Cooling"
- Control of the heating/cooling pumps

Controller module

- Comparison of actual and reference temperatures
- Control of heating/cooling water via connected thermostatic actuators
- Connection of two or six control circuits, extensible as required
- Wired connection of room temperature sensors

Timer module UM (option)

- Time data: Date, time, weekday (leap year detection)
- Automatic switching between daylight saving time and winter time (CEST)
- Temperature reduction adjustment
- Additional pump running time adjustment
- Valve and pump protection function adjustment



Timer module (option) for programming and display of date, time, weekday.

Single room temperature controller

CosiTherm® – wired

Technical specifications

Connections

Base module BM

Max. 9 controller modules D2 or
3 controller modules D6

Controller module D2

Max. 2 room temperature sensors and 8 actuators

Controller module D6

Max. 6 room temperature sensors and 24 actuators

Operating temperature range

Ambient/storage: -10/+60 °C

Base module BM

Supply voltage

AC 230 V, 50-60 Hz

Nominal power

1 VA

Housing

Plastic housing PC/ABS

W x H x D: 122 x 92 x 45 mm

Degree of protection: IP 20 (EN 60529)

Weight

215 g

Controller module

Supply voltage

AC 230 V, DC 5 V (via base module BM)

Nominal power

Controller module D2: 0.1 W

Controller module D6: 0.3 W

Housing (W x H x D)

Plastic housing PC/ABS

Controller module D2: 73 x 92 x 45 mm

Controller module D6: 162 x 92 x 45 mm

Degree of protection: IP 20 (EN 60529)

Weight

Controller module D2: 130 g

Controller module D6: 260 g

Timer module UM (option)

Automatic switching between daylight saving time and winter time (CEST)

Temperature reduction

4 K

Switching channels: 2, independently programmable

Memory blocks: 9, independently programmable

Valve and pump protection function/ additional pump running time

0/15 min, adjustable

Supply voltage

DC 3.3 V (via base module BM)

Nominal power

3 mW

Housing (W x H x D)

Plastic housing PC/ABS

Colour: Light grey, similar to RAL 7047

W x H x D: 37 x 93 x 28 mm

Degree of protection: IP 30 (EN 60529)

Weight

33 g

DG: G, PG: 4	Part no.	Price €
Base module BM	78112	
Controller module D2 for 2 control circuits	78114	
Controller module D6 for 6 control circuits	78115	
Options		
Timer module UM for base module BM	78113	

Single room temperature controller CosiTherm® – wired

Types and dimensions (mm)

Base module BM

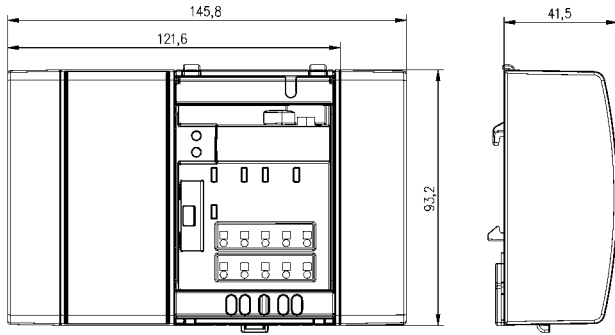

Controller module D2

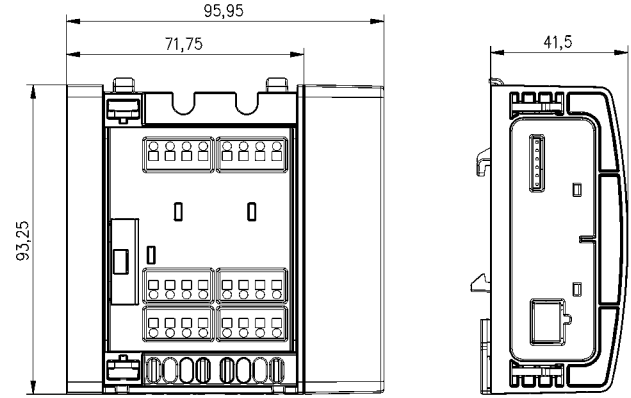

Controller module D6

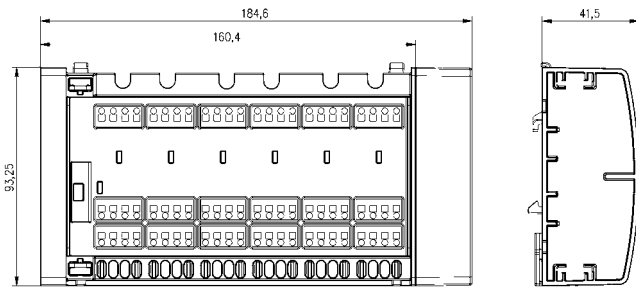

Timer module UM

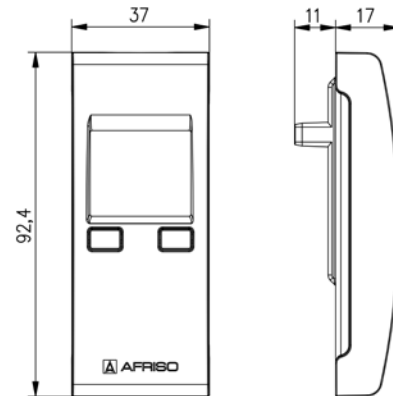

8

Room temperature sensor D – wired



- Extremely flat with a height of 12.5 mm
- Easy surface mounting

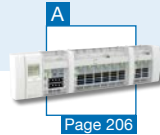

Application Determination of the actual ambient temperature and adjustment of the reference value for the room temperature.

Description The room temperature sensor D transmits the actual ambient temperature as well as the reference room temperature via the connection wire to the single room temperature controller CosiTherm®. The reference value for the room temperature is adjusted by means of the integrated rotary knob. The actual temperature in rooms with an underfloor heating system is compared to the reference temperature on an ongoing basis. If there is a difference, the single room temperature controller CosiTherm® adapts the volume flows of the heating/cooling water via the thermostatic actuators of the manifold system.

Technical specifications

Operating temperature range

Ambient: -10/+60 °C
Storage: -10/+60 °C

Temperature adjustment range

6/30 °C

Temperature reduction

4 K

Supply voltage

DC 5 V, via controller module

Nominal power

0.012 VA

Wired connection

Max. 100 m

Housing

Wall mounting housing made of PC
Colour: White, similar to RAL 9003
W x H x D: 78 x 78 x 12.5 mm
Weight: 30 g
Degree of protection: IP 30 (EN 60529)

Scope of delivery

- Room temperature sensor D
- Mounting kit (2 x screws, 2 x screws)

Dimensions (mm)

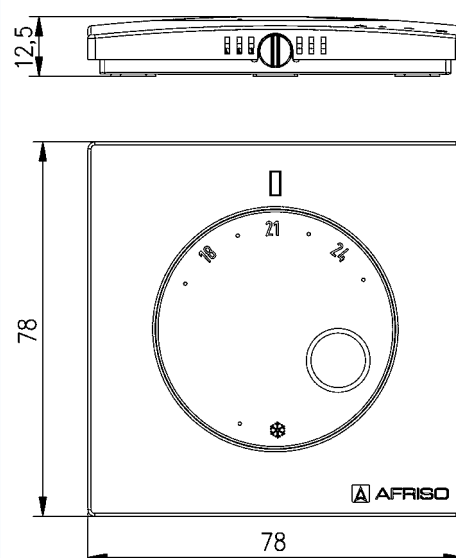

DG: G, PG: 4	Part no.	Price €
Room temperature sensor D	78110	

Single room temperature controller

CosiTherm® Wireless



- Controller terminal bar for connection of actuators
- For manifold systems for heating and cooling
- Worldwide access via the AFRISOhome gateway

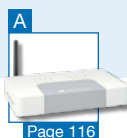

Application Controls the temperature of individual rooms in connection with manifold systems for heating or cooling. EnOcean® wireless technology for integration into building automation systems.

Description The base version of the single room temperature controller CosiTherm® Wireless consists of a base module, at least one controller module with two or six independent control circuits and a corresponding number of room temperature sensors. The controller modules can be interconnected in a modular way to account for the number of control circuits/rooms. One room temperature sensor is required per control circuit; the standard version is battery-less and connected to the controller module via the EnOcean® wireless technology. The room temperature sensor measures the actual temperature in the room. The reference temperature is adjusted via the rotary knob of the room temperature sensor or via the app AFRISOhome. The controller module compares the actual temperature and the reference temperature and controls the volume flow of the heating/cooling water via the thermostatic actuators of the manifold system.

The base module features two independently programmable switching channels for temperature reduction, nine programmable memory blocks and a valve and pump protection function. The additional pump running time is adjustable. The terminals of the controller modules are colour-coded for easy assignment to the wires of the thermostatic actuators; in conjunction with the DIN rail snap connectors at the rear of the housing, this facilitates installation.

With an AFRISOhome gateway, it is possible to remotely check and, if necessary, adjust the room temperatures via the AFRISOhome app (for example, when coming back from winter vacation). This flexible remote control of the room temperature combines multiple benefits: you can increase living comfort and reduce energy costs.

In conjunction with additional AFRISO smart home products with EnOcean® wireless technology, the user can configure a whole range of fully customisable, extensible applications.

Functions **Base module BM**

- Power supply of the thermostatic actuators (AC 230 V)
- Switchover of the system to "Heating" or "Cooling"
- Control of the heating/cooling pumps

Controller module

- Comparison of actual and reference temperatures
- Control of heating/cooling water via connected thermostatic actuators
- Connection of two or six control circuits, extensible
- Connection to room temperature sensors via EnOcean® wireless technology

Single room temperature controller

CosiTherm® – wireless

Technical specifications

Connections

Base module BM

Max. 9 controller modules F2 or
3 controller modules F6

Controller module F2

Max. 2 room temperature sensors and 8 actuators
as well as external antenna

Controller module RM F6

Max. 6 room temperature sensors and 24 actuators
as well as external antenna

Operating temperature range

Ambient/storage: -10/+60 °C

EnOcean® wireless

Frequency: 868.3 MHz

Transmission power: Max. 10 mW

Range: 10 to 30 m (depending on room
arrangement and materials in the
building)

Base module BM

Supply voltage

AC 230 V, 50–60 Hz

Nominal power

1 VA

Housing

Plastic housing PC/ABS

Colour: Light grey, similar to RAL 7047

W x H x D: 122 x 92 x 45 mm

Degree of protection: IP 20 (EN 60529)

Weight

215 g

Controller module

Supply voltage

AC 230 V, DC 5 V (via base module BM)

Nominal power

Controller module F2: 0.3 W

Controller module F6: 0.5 W

Housing (W x H x D)

Plastic housing PC/ABS

Controller module F2: 73 x 92 x 45 mm

Controller module F6: 162 x 92 x 45 mm

Degree of protection: IP 20 (EN 60529)

Weight

Controller module F2: 130 g

Controller module F6: 260 g

i

See operating instructions for detailed information on the range of the EnOcean® wireless module.

DG: G, PG: 4	Part no.	Price €
Base module BM	78112	
Controller module F2A with external antenna, for 2 control circuits	78123	
Controller module F6A with external antenna, for 6 control circuits	78124	

Single room temperature controller

CosiTherm® – wireless



Types and dimensions (mm)

Base module BM

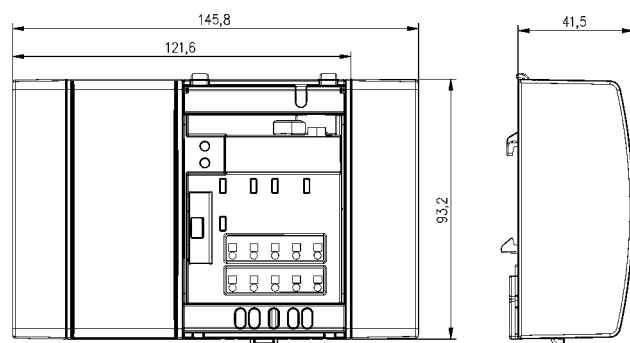

Controller module F2

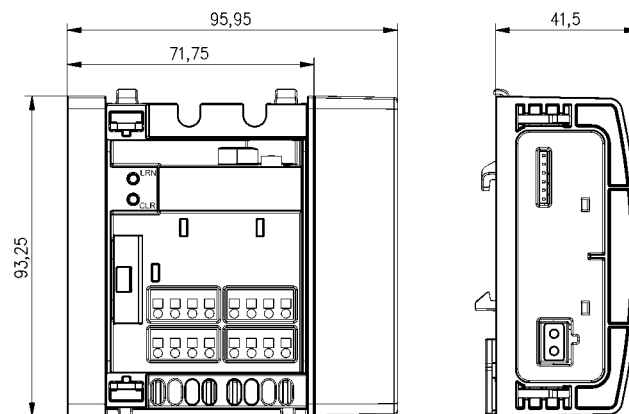

Controller module F6

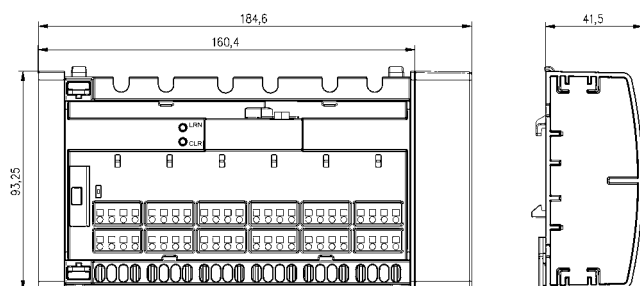

Room temperature sensor FT – wireless

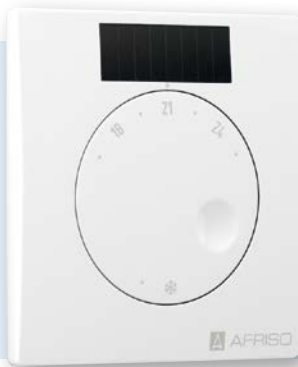

- Extremely flat with a height of 12.5 mm
- No cables required (operation via photovoltaic cell or battery)
- Flexible location-independent use anywhere in buildings

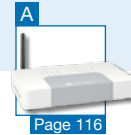
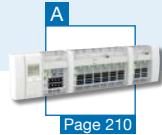

reddot award 2014
winner

Application Determination of the actual ambient temperature and adjustment of the reference value for the room temperature.

Description The room temperature sensor FT transmits the actual ambient temperature as well as the reference room temperature via the integrated EnOcean® wireless module to the single room temperature controller CosiTherm® Wireless or to the AFRISOhome gateway. The reference value for the room temperature is adjusted by means of the integrated rotary knob. The actual temperature in rooms with an underfloor heating system is compared to the reference temperature on an ongoing basis. If there is a difference, the single room temperature controller CosiTherm® Wireless adapts volume flows of the heating/cooling water via the thermostatic actuators of the manifold system. The energy required to send reference temperature and actual temperature values is generated by means of an integrated photovoltaic cell; it is also possible to use a standard battery. The AFRISOhome gateway transmits alarm messages and changes in temperature and/or humidity via WLAN or LAN to the person in charge (for example, to the owner, the facility manager, the janitor or other configured contacts); the message includes information on which room temperature sensor has signalled the change. The AFRISOhome gateway in conjunction with additional AFRISO smart home products with EnOcean® wireless technology allows the user to configure a whole range of fully customisable, extensible applications.

Technical specifications

Operating temperature range

Ambient: -20/+60 °C
Storage: -20/+60 °C

Temperature adjustment range

8/30 °C

Temperature measurement

0/40 °C
Accuracy: ±1 K

Supply voltage

Energy harvesting (via photovoltaic cell)
or type 1632 battery, DC 3 V
(with daylight less than 200 lx)

Housing

Wall mounting housing made of PC
Colour: White, similar to RAL 9003
W x H x D: 78 x 82.5 x 12.5 mm
Weight: 43 g
Degree of protection: IP 30 (EN 60529)

EnOcean® wireless

EEP: A5-10-03
Frequency: 868.3 MHz
Transmission power: Max. 10 mW
Range: 10 to 30 m (depending on room arrangement and materials in the building)

Scope of delivery

- Room temperature sensor FT
- 4 x adhesive dots
- Without battery

Necessary additional components

- CosiTherm® wireless and/or
- AFRISOhome gateway

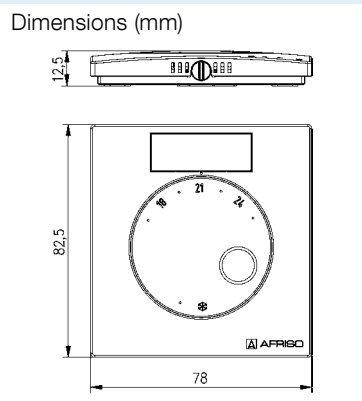

i

See operating instructions for detailed information on the range of the EnOcean® wireless module.

DG: L, PG: 4	Part no.	Price €
Room temperature sensor FT (temperature)	78111	

Single room temperature controller FloorControl controller terminal bar WB 01 – wired



- Controller terminal bar for connection of actuators and room thermostats
- For manifold systems for heating and cooling
- Suitable for room temperature sensors series RT – wired



Application Controls the temperature of individual rooms in connection with manifold systems for heating (cooling function depends on room temperature sensor used).

Description The single room temperature controller FloorControl is a complete system consisting of a terminal block with the corresponding number of room thermostats. The controller terminal bar has eight control circuits. One room thermostat is required per control circuit; it is wired to the controller terminal bar. Up to four thermostatic actuators can be connected to each of the control circuits 1 to 3; a maximum of two actuators can be connected to the thermostatic actuators 4 to 8.

The room thermostat measures the actual temperature in the corresponding rooms. The reference temperature is adjusted by means of the keys of the room thermostat. The room thermostat then switches the thermostatic actuator via the controller terminal bar to control the heating circuit at the manifold.

Functions and features

Controller terminal bar WB 01

For controlling the reference temperature. Versions:

- WB 01 D-8-24: Power supply for the thermostatic actuators (DC 24 V) and supply of the contacts of the room thermostat (battery operation only)
- WB 01 D-8-230: Power supply for the thermostatic actuators (AC 230 V) and supply of the contacts of the room thermostat (AC 230 V or battery operation only)

Technical specifications

Connections

Max. 8 control circuits and 22 actuators
Max. 1 room thermostat per control circuit

Operating temperature range

Ambient/storage: 5/50 °C

Supply voltage

WB 01 D-8-24: 24 V
WB 01 D-8-230: 230 V

Nominal power

4.948 VA

Housing

Plastic housing ABS
B x H x T: 335 x 106 x 72 mm
Colour: White (RAL 9003)
Degree of protection: IP 20 (EN 60529)

Weight

Without mains cable
WB 01 D-8-230: 766 g
WB 01 D-8-24: 751 g

Compatibility

Room thermostat	Controller terminal bar	
	WB 01 D-8-230	WB 01 D-8-24
TA 03	•	•
RT 01 D-230	•	
RT 01 D-BAT	•	•
RT 05 D-230	•	
RT 05 D-BAT	•	•
Actuators	230 V	24 V



Single room temperature controller FloorControl controller terminal bar WB 01 – wired

Connection controller terminal bar WB 01 D-8-230

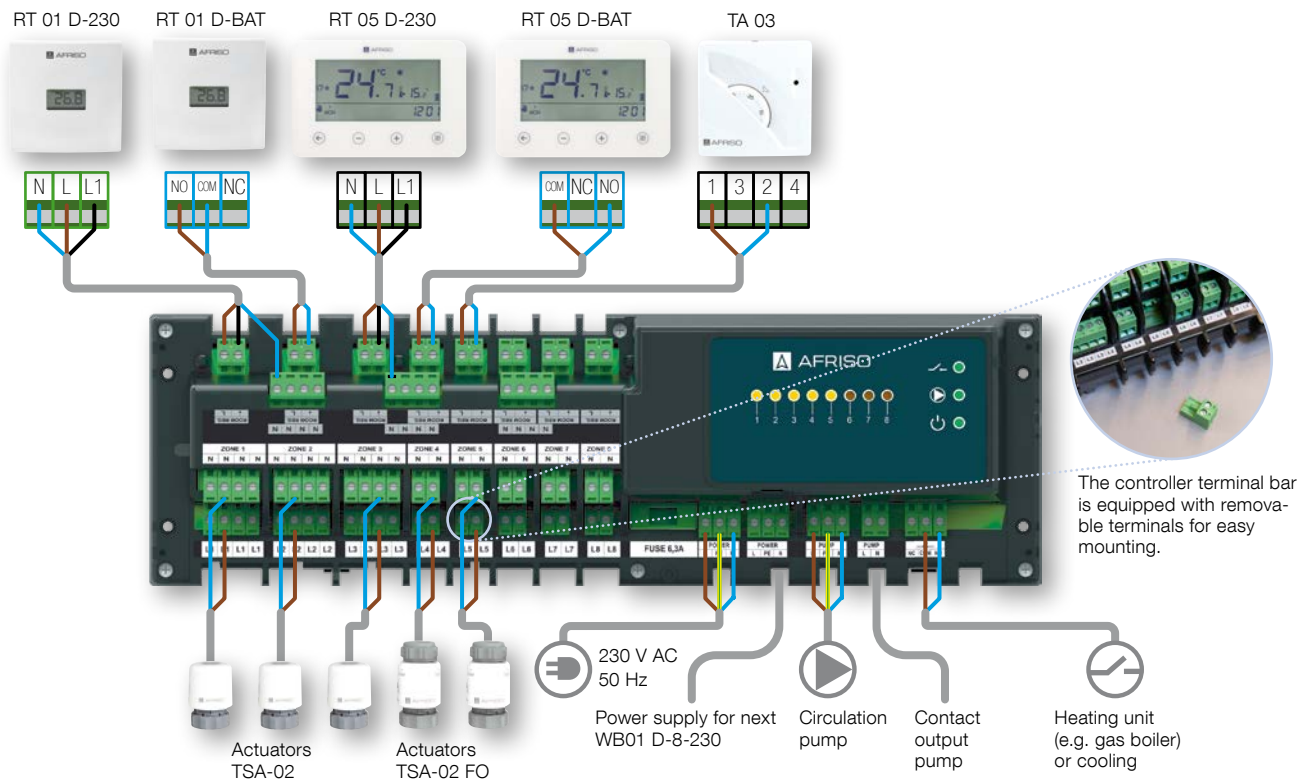

i Room thermostats D-BAT require a cable 2 x 0.5 mm², room thermostats D-230 a cable 3 x 0.5 mm².

Connection controller terminal bar WB 01 D-8-24

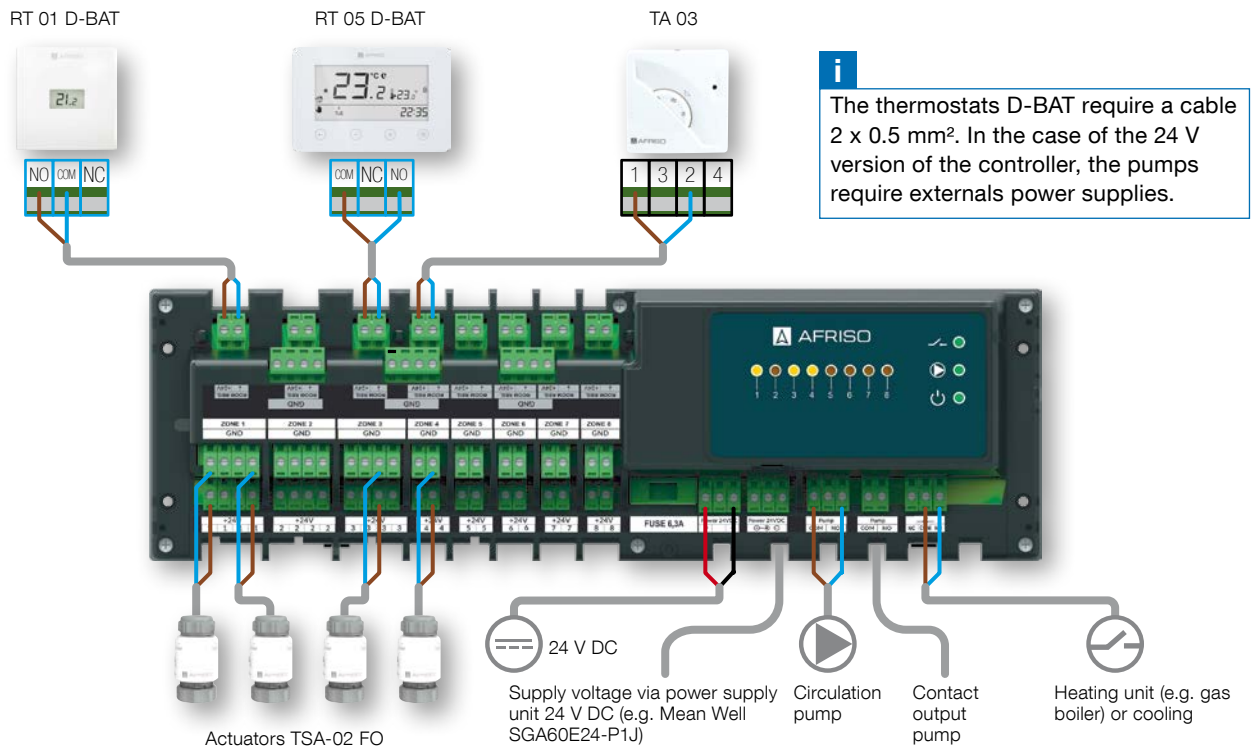

DG: G, PG: 4	Part no.	Price €
Controller terminal bar WB 01 D-8-230 for 8 control circuits (230 V)	86013	
Controller terminal bar WB 01 D-8-24 for 8 control circuits (24 V)	86014	

Room thermostats TA 03 for controller terminal bar WB 01



- Mechanical temperature controllers with lamp and on/off switch
- For room temperature control
- Switch-off function for the summer months
- Easy surface mounting
- Universal use, also for standard controllers

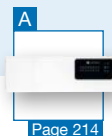

Application Mechanical room thermostats for domestic applications. On-wall wall mounting allows for retrofitting.

Description The temperature measured at the probe causes a change in the volume of the measuring liquid. The force acting triggers electrical switching. For optimum temperature control, the room thermostat should be installed at an inside wall opposing radiators. Install the room thermostat away from heat source of all kinds and from draft and do not expose it to sunlight. The best installation height is approx. 1.5 m above the floor.

Technical specifications

Operating temperature range

Ambient: 0/50 °C
Storage: 0/50 °C

Temperature adjustment range

7/30 °C

Switching differential

$\Delta T \leq 1$ K

Temperature change rate

1 K/15 minutes

Setting

Externally adjustable

Probe element

Liquid-filled

Housing

Wall mounting housing made of PVC
Colour: White (RAL 9016)
W x H x D: 80 x 80 x 44 mm
Weight: 134 g
Degree of protection: IP 20 (EN 60529)

Electrical switching contact

Changeover contact

Contact rating

NC 16 (2.5) A 250 V AC
NO 16 (2.5) A 250 V AC

			Compatibility		Part no.	Price €
DG: G, PG: 4	Lamp	On/off switch	WB 01-D-8-230	WB 01-D-8-24		
TA 03	-	-	•	•	42616X	
TA 03	•	-	•	-	42617X	
TA 03	•	•	•	-	42618X	
TA 03	•	Summer/winter	•	-	42619X	

Room thermostats TA 03 for controller terminal bar WB 01

Types and dimensions (mm)

TA 03

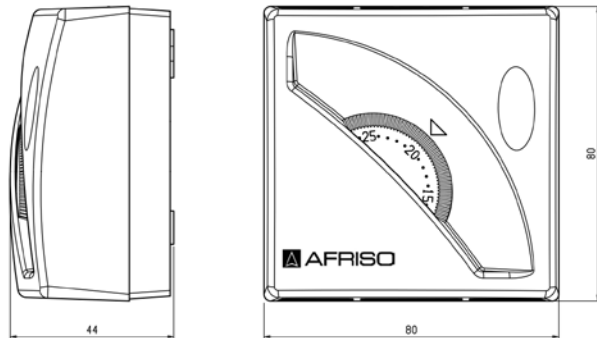

Wiring diagram

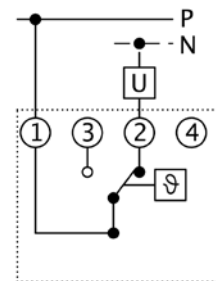

TA 03 without switch, with lamp

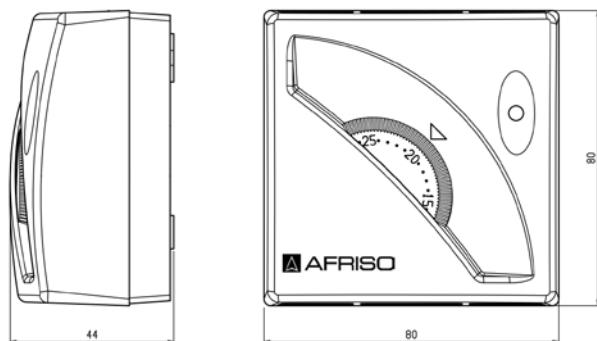

Wiring diagram

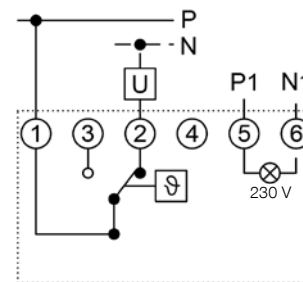

TA 03 with switch, with lamp

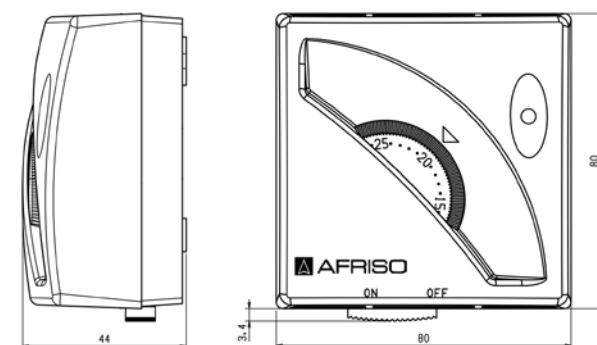

Wiring diagram

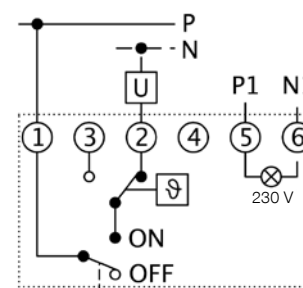

Room thermostats RT 01 for controller terminal bar WB 01



- Compact, modern design
- Easy surface mounting or mounting to standard in-wall switch boxes
- Either as 230 V or as battery version
- Suitable for heating and cooling



Application Determination of the actual ambient temperature and adjustment of the reference value for the room temperature. Can also be used for cooling (manual switching).

Description The room thermostat RT 01 is a part of the complete system FloorControl for single-room temperature control. Each room thermostat measures the actual ambient temperature and switches the output to obtain the required reference temperature. The reference value for the room temperature is adjusted by means of the keys. The integrated display shows the values. The actual temperature in rooms with an underfloor heating system is compared to the reference temperature on an ongoing basis.

Versions:

- RT 01 D-BAT: Version with battery, suitable for wall mounting
- RT 01 D-230: 230 V version, suitable for mounting to standard junction boxes/in-wall switch boxes

Technical specifications

Operating temperature range

Ambient/storage: 5/50 °C

Temperature adjustment range

5/35 °C

Accuracy: ±0.5 K

Supply voltage

Either AC 230 V or battery, see ordering table

Nominal power

RT 01 D-230: 5.396 VA

Contact rating

NO/NC: Max. 1A 250 V AC

Housing

Plastic, PC-ABS

Colour: White (RAL 9003)

Degree of protection IP 20 (EN 60529)

Weight

RT 01 D-230: 105 g

RT 01 D-BAT: 84 g

Scope of delivery

- RT 01 D-BAT: With battery

8

Types and dimensions (mm)

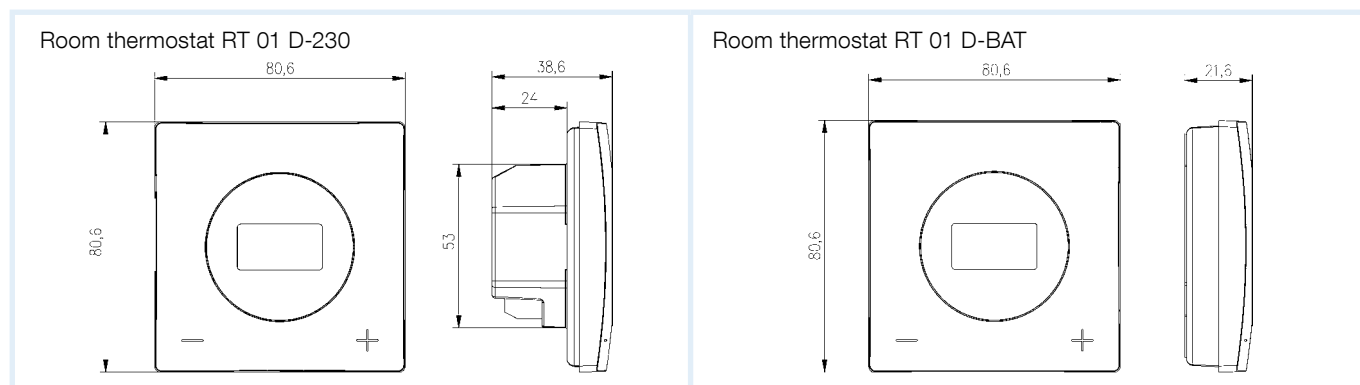

	Compatibility		Part no.	Price €
DG: G, PG: 4	WB 01 D-8-230	WB 01 D-8-24		
Room thermostat RT 01 D-230 (230 V)	•		86018	
Room thermostat RT 01 D-BAT (battery)	•	•	86017	

Room thermostats RT 05 for controller terminal bar WB 01



- Compact, modern design
- Easy mounting on standard in-wall switch boxes
- Either as 230 V or as battery version
- Large display with additional information
- Timer programs can be stored
- Suitable for heating and cooling



Application Determination of the actual ambient temperature and adjustment of the reference value for the room temperature.
Can also be used for cooling (manual switching).

Description The room thermostat RT 05 is a part of the complete system FloorControl for single-room temperature control. Each room thermostat measures the actual ambient temperature and switches the output to obtain the required reference temperature. The reference value for the room temperature is adjusted by means of the keys. The actual temperature in rooms with an underfloor heating system is compared to the reference temperature on an ongoing basis. In addition to the reference temperature, you can store timer programs (e.g. Day/Night). The display shows values such as temperature, time or battery status. Both versions are suitable for mounting to junction boxes or in-wall switch boxes.

Versions:

- RT 05 D-BAT: Version with battery
- RT 05 D-230: 230 V version

Technical specifications

Programs

- Day and night mode
- Week program:
Same setting for all days
- Day program:
Different setting for each day

Operating temperature range

Ambient/storage: 5/50 °C
Operation: Max. 50 °C

Temperature adjustment range

5/35 °C
Accuracy: ±0.5 K

Supply voltage

Either AV 230 V or battery

Nominal power

RT 05 D-230: 1.175 VA

Contact rating

NO/NC: Max. 1A 250 V AC

Housing

Plastic, PC
Colour: White (RAL 9003)
Degree of protection IP 20 (EN 60529)

Weight

RT 05 D-230: 189 g, RT 05 D-BAT: 166 g

Scope of delivery

- RT 05 D-BAT: With battery

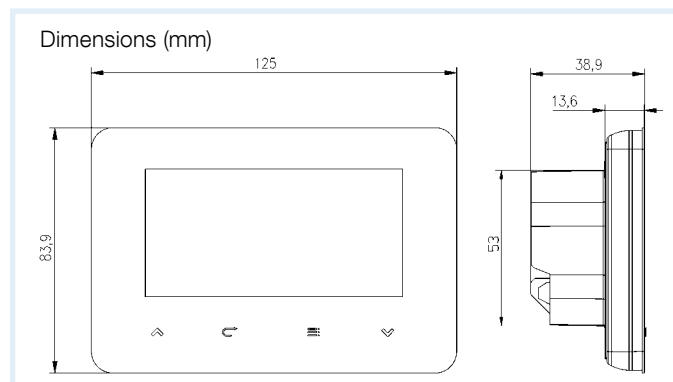

DG: G, PG: 4	Compatibility		Part no.	Price €
	WB 01 D-8-230	WB 01 D-8-24		
Room thermostat RT 05 D-230 (230 V)	•		86019	
Room thermostat RT 05 D-BAT (battery)	•	•	86020	

Thermostatic actuator TSA-02



- Stroke indicator via grey rod on cap
- Either as 24 V or as 230 V version
- Slim design (Ø 39 mm)

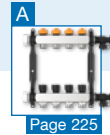
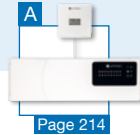

Application For controlling the hot water valves in radiators or AFRISO distribution manifolds such as heating/cooling circuit manifolds ProCalida® MC, EF and VA or industrial manifolds IN. Actuators convert the electrical signal received from room or timer thermostats into a valve stroke to control the set temperature via the flow volume.

The actuator is factory-closed and thus ready for automatic operation.

Description Electro-thermostatic actuator with position indication, connection cable and union nut for direct connection to the valve or upper part of the manifold. Closed when de-energised; available as 24 V or as 230 V version.

Technical specifications

Operating mode

Closed when de-energised (NC)

Stroke

> 3.2 mm
Indication via rods on hood

Opening time

5–6 minutes

Operating temperature range

Ambient: Max. 60 °C

Supply voltage

AC/DC 24 V or AC 230 V
Power: 2 W

Connection

Union nut M30 x 1.5 mm

Closing dimension

10.8 mm

Cable length

1 m

Housing

Plastic
Degree of protection IP 54 (EN 60529)

Dimensions

H x Ø: 56 x 39 mm

Actuating force

Approx. 90 N

8

i

AFRISO offers customer-specific versions of the actuators for many valve upper parts for OEMs. We look forward to your enquiry.

DG: G, PG: 4			Part no.	Price €
TSA-02, 230 V	1	10	78882	
TSA-02, AC/DC 24 V	1	10	78883	

Thermostatic actuator TSA-02 FO



- First Open function
- Manual Re-Open function without power applied
- Auto Spin function
- Stroke indicator
- Either as 24 V or as 230 V version
- Slim design (Ø 39 mm)

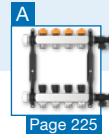
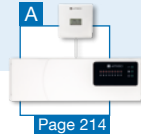

Application For controlling the hot water valves in radiators or AFRISO distribution manifolds such as heating/cooling circuit manifolds ProCalida® MC, EF and VA or industrial manifolds IN. Actuators convert the electrical signal received from room or timer thermostats into a valve stroke to control the set temperature via the flow volume.

The actuator is factory-opened (First Open function) so that the stroke valves at the heating circuit manifold remain open during initial commissioning. This facilitates mounting as well as filling and flushing of the system since, at this point in time, the control system is usually not yet operative. The First Open function (FO) is automatically disabled (Auto Spin function) as soon as the actuator is electrically connected and fully closed. The FO function can also be disabled manually by turning the upper hand wheel to the left by 90° to set automatic mode at the actuator.

For servicing, the factory setting "open" of the actuator can be restored manually via the hand wheel without power having to be applied (Re-Open function). The slim design (housing diameter 39 mm) allows for installation to manifolds with a heating circuit distance of 40 mm.

Description Electro-thermostatic actuator with First Open and Re-Open functions, position indication, connection cable and union nut for direct connection to the valve or upper part of the valve. Closed when de-energised; available as 24 V or as 230 V version.

Technical specifications

Functions

First Open and Re-Open functions (adjustable via hand wheel), Auto Spin function

Operating mode

Closed when de-energised (NC)
Condition as delivered: Open

Stroke

> 3.2 mm
Indication via rod
Actuating force 90 N or 110 N

Opening time

Approx. 5–6 minutes

Operating temperature range

Ambient: Max. 60 °C

Supply voltage

AC/DC 24 V or AC 230 V
Power: 2 W

Connection

Union nut M30 x 1.5 mm

Closing dimension

10.8 mm

Cable length

1 m

Housing

Plastic
Degree of protection IP 54 (EN 60529)



Dimensions

H x Ø: 72 x 39 mm

8

i

AFRISO offers customer-specific versions of the actuators for many valve upper parts for OEMs. We look forward to your enquiry.

DG: G, PG: 4	Actuating force			Part no.	Price €
TSA-02 FO, AC 230 V	90 N	10	100	79014	
TSA-02 FO, AC/DC 24 V	90 N	10	100	79015	
TSA-02 FO, AC 230 V	110 N	10	100	79016	
TSA-02 FO, AC/DC 24 V	110 N	10	100	79017	

Minimum order quantity for non-stock items = 100 pieces; delivery only in packing units.

Thermostatic actuator TSA-03



- Stroke indicator via grey rod on cap
- With integrated limit switch for circulation pump
- Either as 24 V or as 230 V version
- Compact design



Page 214

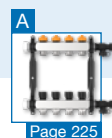

Page 225

Application For controlling the hot water valves in radiators or AFRISO distribution manifolds such as heating/cooling circuit manifolds ProCalida® MC, EF and VA or industrial manifolds IN. Actuators convert the electrical signal received from room or timer thermostats into a valve stroke to control the set temperature via the flow volume.

The actuator is factory-closed and thus ready for automatic operation.

Description Electro-thermostatic actuator with position indication, limit switch, connection cable and union nut for direct connection to the valve or upper part of the valve. Closed when de-energised. TSA 03 can be used to switch off the pump via the integrated limit switch when all valves are closed.

8

Technical specifications

Operating mode

Closed when de-energised (NC)

Stroke

> 3.2 mm

Indication via rods on hood

Opening time

Approx. 5–6 minutes

Operating temperature range

Ambient: Max. 60 °C

Supply voltage

AC/DC 24 V or AC 230 V

Power: 2 W

Switching output

1 voltage-free, normally open contact

Contact rating

AC/DC 24 V, max. 6 A / 2 A

AC 230 V, max. 6 A / 0.1 A

Connection

Union nut M30 x 1.5 mm

Closing dimension

10.8 mm

Cable length

1 m

Housing

Plastic

Degree of protection IP 40 (EN 60529)

Dimensions

H x W x L: 57 x 39 x 52 mm

Actuating force

Approx. 90 N

i

AFRISO offers customer-specific versions of the actuators for many valve upper parts for OEMs. We look forward to your enquiry.

DG: G, PG: 4			Part no.	Price €
TSA-03, AC 230 V with limit switch	1	10	78871	
TSA-03, AC/DC 24 V with limit switch	1	10	78872	

Single room controller RTL-Box 324 Vario with return temperature limiter



- Very compact visible plate (11.5 x 13.5 cm) made of high-gloss plastics
- Elegant, compact control head
- Exact alignment with mounting wall due to depth-adjustable mounting frame
- Aesthetic design allows for user-friendly mounting at the level of the light switches

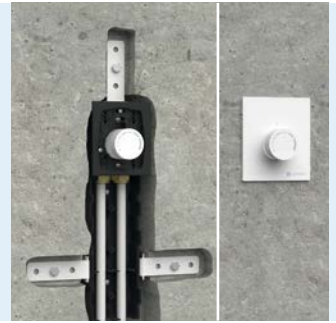

Application For decentralised temperature control in individual rooms with underfloor heating systems or wall heating systems in combination with radiator installation. Ideal for scenarios without radiator installation and if no centralised distribution is desired. The RTL-Box 324 Vario combines heating circuit, room temperature sensor and control in a single unit. The purely mechanical function of the room controller requires neither additional electrical power nor actuators nor similar equipment. Due to the compact dimensions and the aesthetic design, the RTL-Box fits perfectly at the level of light switch installations. This ensures optimum control characteristics and excellent user-friendliness.

Description The single room controller RTL-Box 324 Vario consists of a high-grade, high-gloss cover plate made of sturdy plastic, an aesthetic thermostat control head and a mounting frame. The mounting frame adapts to the wall and levels a height of up to 25 mm. The optional extension kit extends the thermostat head by 20 mm if the maximum wall level height is exceeded. The wall installation box with shell protection comprises an adjustable valve assembly consisting of a control valve, a thermostat valve and a return temperature limiter for limiting the radiator return temperature to a temperature level suitable for the underfloor heating system. The valve opens when the values falls below the adjusted limit value. The pipes of the underfloor heating system are mounted in the wall installation box by means of standard compression fittings.

Technical specifications

Temperature adjustment range

Reference: 8/28 °C (room temperature)
Return temperature: 20/48 °C

Operating temperature range

Medium: $T_{max} = 90$ °C

System connections

Connector with eurocone, can be fixed with spring clips

Pipe connection

Eurocone G $\frac{3}{4}$

Nominal pressure

Max. 6 bar

Installation depth

Min. 63 mm
Max. 88 mm

Housing

Plastic cover (PC/ABS)
High-gloss white
Plastic wall installation box (PP) black
Weight: 1.25 kg

DG: G, PG: 4	Part no.	Price €
Single room controller RTL-Box 324 Vario	78330	
Accessories		
Extension kit RTL-Box 324 Vario	78331	

Single room controller RTL-Box 324 Vario with return temperature limiter

Types and dimensions (mm)

Cover with wall installation box

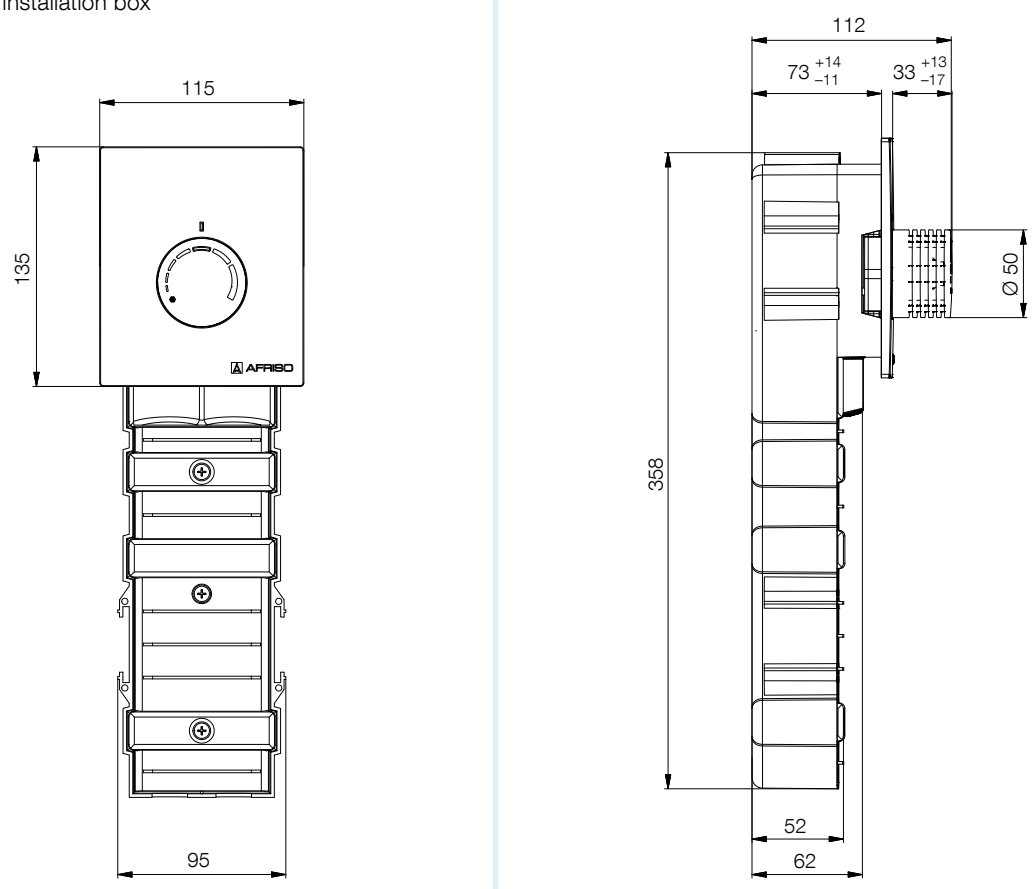

8

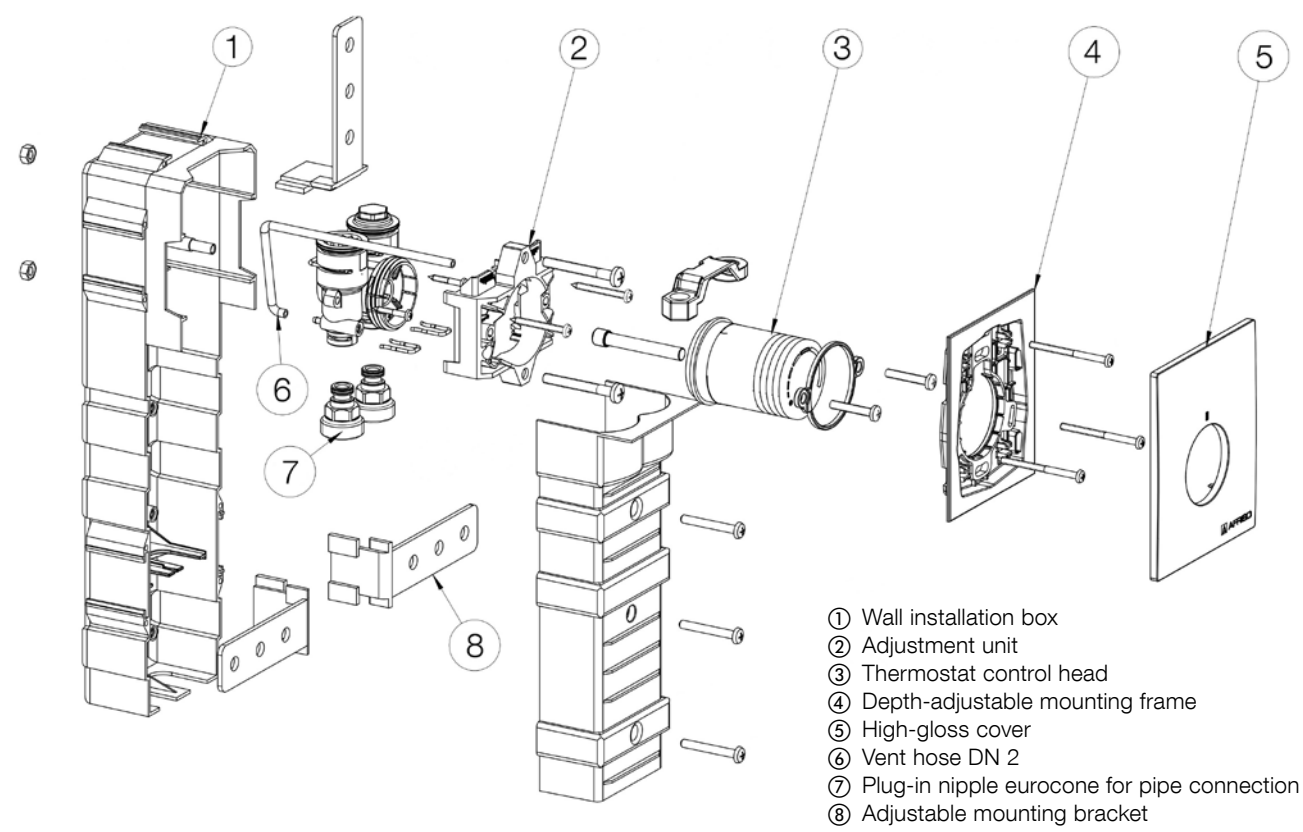

- ① Wall installation box
- ② Adjustment unit
- ③ Thermostat control head
- ④ Depth-adjustable mounting frame
- ⑤ High-gloss cover
- ⑥ Vent hose DN 2
- ⑦ Plug-in nipple eurocone for pipe connection
- ⑧ Adjustable mounting bracket

Stainless steel heating circuit manifold ProCalida® VA 1C Vario-DP with dynamic control valve for hydraulic balancing

Valve pre-adjustment

The dynamic control valve Vario-DP is fully adjustable with a standard radiator bleed screw key. The numerical scale with intermediate points allows for precise adjustment of the calculated values (e.g. from the AFRISO TOOLBOX app) in the flow range from 20–340 l/h.

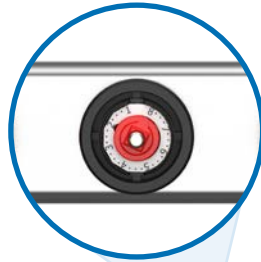

Thermostatic actuators TSA-02/03
For electronic control of the return valves. Actuators convert the electric signal they receive from room thermostats or thermostats with timers into a valve stroke to control the set temperature. With connection cable and union nut for direct connection to the return line.

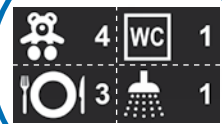

Adhesive label

For easy designation of the heating circuits.

Ergonomic hand wheel

For fast opening and closing of the heating circuit.

Patented control valve Vario-DP

With dynamic volume flow limiter for automatic hydraulic balancing. The control membrane is installed directly in the control valve and the valve spindle is used as the pressure sensor – therefore, there are no additional control components which might be subject to pollution. The system Vario-DP operates with a standard valve gasket and does not require additional dirt filters.

8



Wall bracket

For fast, safe and easy installation of manifold systems.



End cap / end piece

The manifold end is equipped with a plastic end piece for filling and draining. The surface heating/cooling system can be subjected to a pressure test prior to commissioning via the opening of the end cap. For this purpose, AFRISO offers the CAPBs® set PT 70-FBH, a flexible testing system for tightness tests with a suitable adapter.



Ball valve

High-grade ball valve DN 25, with or without thermometer.

Stainless steel heating circuit manifold

ProCalida® VA 1C Vario-DP



- Dynamic control valves for controlling the water volume
- Fast and safe mounting with union nut (flat-sealing)
- Sound-absorbing plastic wall bracket with quick mounting function
- 100 % tightness-tested and function-tested



Application Manifold system for surface heating systems and cooling systems with dynamic control valves for constant control of the water volume. For distribution of heating and cooling circuit water as per VDI 2035 or of water/glycol mixtures in sealed systems. Suitable for 2–12 heating/cooling circuits.

Description Stainless steel heating circuit manifold with polished surface. Return with dynamic control valve for constant control of the water volume in each heating circuit. Return valves with dual O ring seal at the valve axis. The control range is 20–340 l/h. The typical manual adjustment of the valves is therefore no longer required. Connection by means of angular connection pieces and/or ball valve G1. End module with filling and drain valve G $\frac{3}{4}$ eurocone which can also be used for manual venting. Easy mounting by means of plastic wall bracket with excellent sound-absorbing characteristics and with quick mounting function – the manifold is snap-mounted to the wall bracket. Suitable for standard manifold cabinets. With a sufficient distance between the flow and return bars, for easy, collision-free mounting even in the case of large actuator and heating circuit pips up to 20 mm. AFRISO stainless steel manifold systems are 100 % tightness-tested and function-tested.

Technical specifications

Number of heating/cooling circuits

2–12

Medium

Heating circuit water and cooling water as per VDI 2035 (Water/glycol mixtures with an admixture of max. 50 %)

Test pressure

Max. 6 bar

Manifold pipe

Stainless steel 304 (1.4301)

Main connection

G1 flat-sealing, with union nut
Connection from the right or from the left

Connection heating/cooling circuit

G $\frac{3}{4}$ male thread, eurocone suitable for standard compression fittings

Operating temperature range

Medium: -20/+90 °C at 3 bar
-20/+80 °C at 4 bar
-20/+70 °C at 5 bar
-20/+60 °C at 6 bar

Wall bracket

Impact-resistant plastic with rubber support, complies with DIN 4109, suitable for standard manifold cabinets
Bar distance: 220 mm

Flow valves

Can be shut off

Dynamic return valves

Mating thread: M30 x 1.5 mm
Male thread
Closing force: < 80 N
Closing dimension: 12 +/- 0.6 mm
(open position 15 mm)
Adjustment range: 20 to 340 l/h
Operating range: 50 to 700 mbar
Dynamic control range: 150 to 700 mbar

Suitable for electro-thermostatic actuators TSA-02/-03 from AFRISO or for standard actuators with union nut M30 x 1.5 mm



Stainless steel heating circuit manifold

ProCalida® VA 1C Vario-DP

i

Dynamic control valve - for automatic hydraulic balancing

Advantages – your benefits

- + Automatic control of water volume per heating circuit
- + Fast hydraulic balancing
- + Adjusted flow rate is not exceeded
- + High reserve due to very wide adjustment range up to 340 l/h
- + Geometry of valve insert provides protection against unwanted pollution
- + No additional line fittings required for balancing of the individual stations or floors



8

Technical specifications manifolds, heating/cooling circuits

Heating circuits	2	3	4	5	6	7	8	9	10	11	12
Volume flow max. [m ³ /h]*	0.48	0.72	0.96	1.20	1.44	1.68	1.92	2.16	2.40	2.64	2.88
Kvs [m ³ /h]	2.65	3.95	4.96	6.04	6.82	7.77	8.29	9.08	9.52	10.02	10.42
Δp manifold [mbar]	33	33	37	40	45	47	54	57	64	69	76
Δp pipe e.g. [mbar]**	250	250	250	250	250	250	250	250	250	250	250
Δp total [mbar]	283	283	287	290	295	297	304	307	314	319	326
Heating capacity at 10 K max. [kW]	5.6	8.4	11.2	14.0	16.7	19.5	22.3	25.1	27.9	30.7	33.5
Heating capacity at 5 K max. [kW]	2.8	4.2	5.6	7.0	8.4	9.8	11.2	12.6	14.0	15.4	16.7

* Maximum volume flow per heating circuit: 4 l/min = 0.24 m³/h.

**Note: Use an appropriate pipe diameter.

Δp pipe at 0.24 m³/h approx.: Dim. 20 = 1.2 mbar/m; Dim. 17 = 3.1 mbar/m; Dim. 16 = 4.5 mbar/m.

Stainless steel heating circuit manifold ProCalida® VA 1C Vario-DP

Types and dimensions (mm)

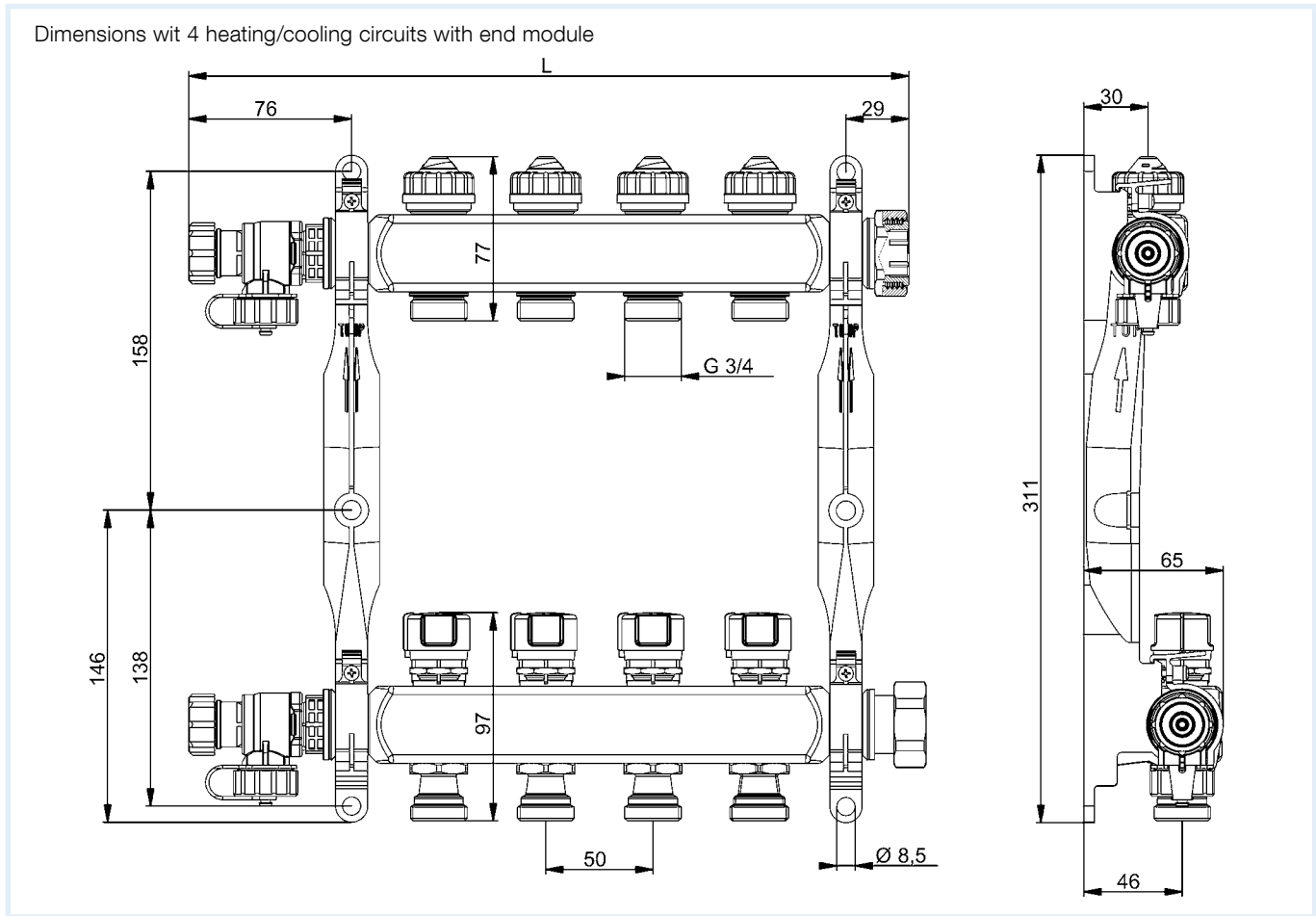

Dimensions (mm)

Version	2 HK FM	3 HK FM	4 HK FM	5 HK FM	6 HK FM	7 HK FM	8 HK FM	9 HK FM	10 HK FM	11 HK FM	12 HK FM
Distance wall bracket	130	180	230	280	330	380	430	480	530	580	630
Total length L manifold	236	286	336	386	436	486	536	586	636	686	736

Pre-adjustment water volume for Vario-DP

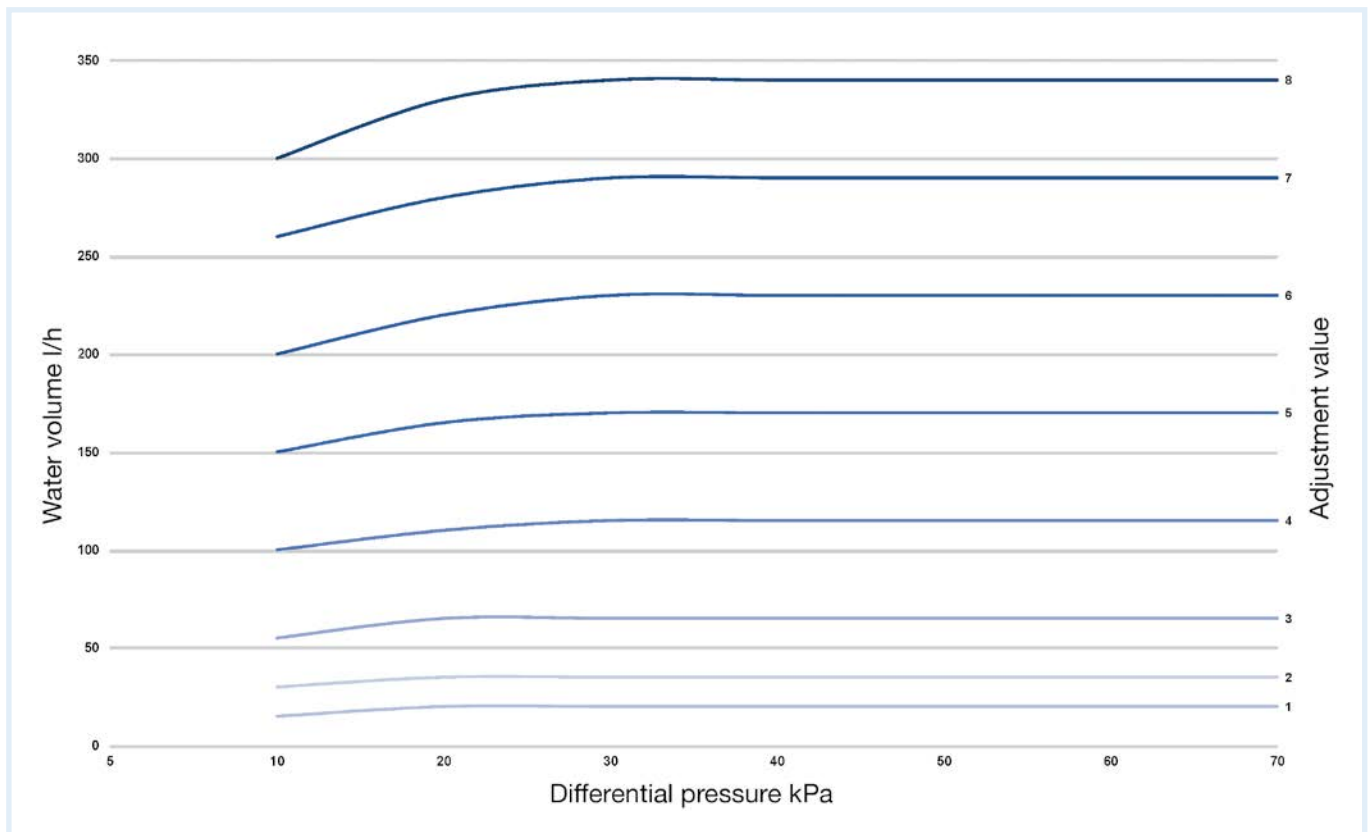



Adjustment table

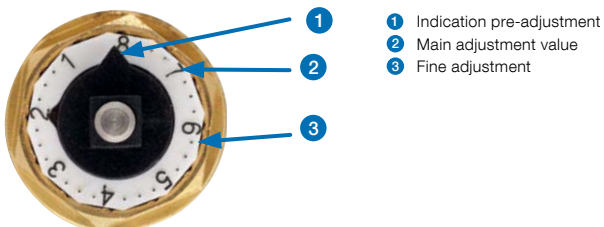

Pre-adjustment	1	1•	1••	1•••	2	2•	2••	2•••	3	3•	3••	3•••	4	4•	4••	4•••	5	5•	5••	5•••	6	6•	6••	6•••	7	7•	7••	7•••	8	
	Water volume in l/h:																													
Differential pressure: 15–70 kPa	20	20	25	25	35	40	45	55	65	80	90	100	115	135	145	160	170	185	200	215	230	245	260	275	290	300	315	330	340	

Example valve pre-adjustment



Stainless steel heating circuit manifold ProCalida® VA 1C Vario-DP

DG: G, PG: 3	Number of heating circuits			Part no.	Price €
Stainless steel heating circuit manifold ProCalida® VA 1C Vario-DP	2	1	-	86422	
Stainless steel heating circuit manifold ProCalida® VA 1C Vario-DP	3	1	-	86423	
Stainless steel heating circuit manifold ProCalida® VA 1C Vario-DP	4	1	-	86424	
Stainless steel heating circuit manifold ProCalida® VA 1C Vario-DP	5	1	-	86425	
Stainless steel heating circuit manifold ProCalida® VA 1C Vario-DP	6	1	-	86426	
Stainless steel heating circuit manifold ProCalida® VA 1C Vario-DP	7	1	-	86427	
Stainless steel heating circuit manifold ProCalida® VA 1C Vario-DP	8	1	-	86428	
Stainless steel heating circuit manifold ProCalida® VA 1C Vario-DP	9	1	-	86429	
Stainless steel heating circuit manifold ProCalida® VA 1C Vario-DP	10	1	-	86430	
Stainless steel heating circuit manifold ProCalida® VA 1C Vario-DP	11	1	-	86431	
Stainless steel heating circuit manifold ProCalida® VA 1C Vario-DP	12	1	-	86432	

DG: G, PG: 2						
Accessories	Description			DG	Part no.	Price €
	Ball valve kit with thermometer NG 50 G1 male x G1 female nickel-plated with indication, red/blue	1	-	G	80460	

8

Pump assembly PrimoTherm® Floor 130 for manifold systems

NEW

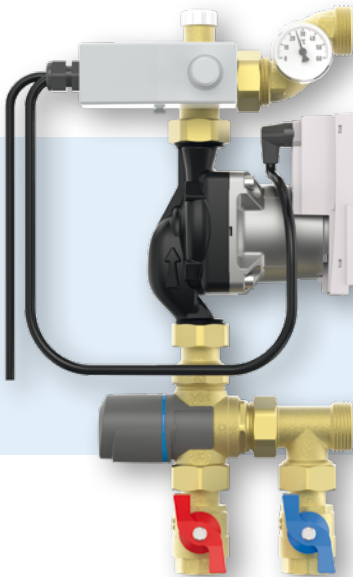

- Pre-assembled and tightness-tested assembly
- Flow temperature fully adjustable between 35 and 60 °C
- Mixing valve cap with window and scale, can be lead-sealed (ideal for public facilities)
- With shut-off ball valves

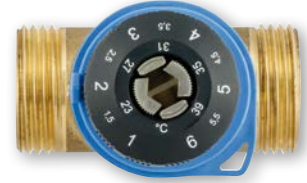

Mixing valve control knob with temperature scale

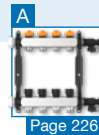

Application Pump assembly for constant control of the flow temperature of water-based surface heating systems. With the integrated thermostatic mixing valve, the flow temperature can be adjusted to a desired temperature by adding water from the return. Due to the eccentrical screw connection with variable distance, PrimoTherm is suitable for almost all manifold systems.

Description Complete, pre-assembled and tightness-tested pump assembly with all required functional components, including shut-off ball valve DN 20. The required flow temperature is set within a range from 35 to 60 °C at the thermostatic mixing valve mixing valve ATM 563. A cover that can be lead-sealed protects the control knob against improper adjustments during operation. The selected adjustment is visible through the window in the cap. The new chamber geometry also helps to avoid damage caused by overpressure during closing (backflow preventer to return).

The circulation pump automatically switches off if a safety-related temperature limitation is exceeded. It is adjustable between 20 to 60 °C; the factory setting is 55 °C. This helps to prevent damage to the underfloor heating system. The pump features the following operating modes:

- Constant volume flow
- Constant pressure
- Venting function of pump housing

In venting mode, the entire surface heating/cooling system can be conveniently vented by means of the valve integrated in the pump assembly and the enclosed vent hose.

Technical specifications

System connections

Primary end: G $\frac{3}{4}$ female
Manifold end: G1 male

Operating temperature range

Medium: Max. 90 °C
(short-term 110 °C)

System pressure

Max. 6 bar

Flow coefficient Kvs

2.5 m²/h

Supply voltage

AC 230 V, 50 Hz

Dimensions

W x H x D: 200 x 370 x 88 mm

Thermostatic mixing valve ATM 563

Adjustment range: 35/60 °C
Housing: Brass (CW626N),
dezincification-resistant
Cap/control head: Plastic ABS/PBT
Seals: EPDM

Circulation pump WILO Yonos PARA 15/6 RKA 130

Length: 130 mm
Degree of protection: IP 44
Max. capacity: 3.3 m³/h
Max. pump head: 6 m

Options ▪ Other circulation pumps

DG: G, PG: 4	Part no.	Price €
Pump assembly PrimoTherm® Floor 130	77490	

Pump assemblies PrimoTherm® Floor 130 for manifold systems



Dimensions (mm)

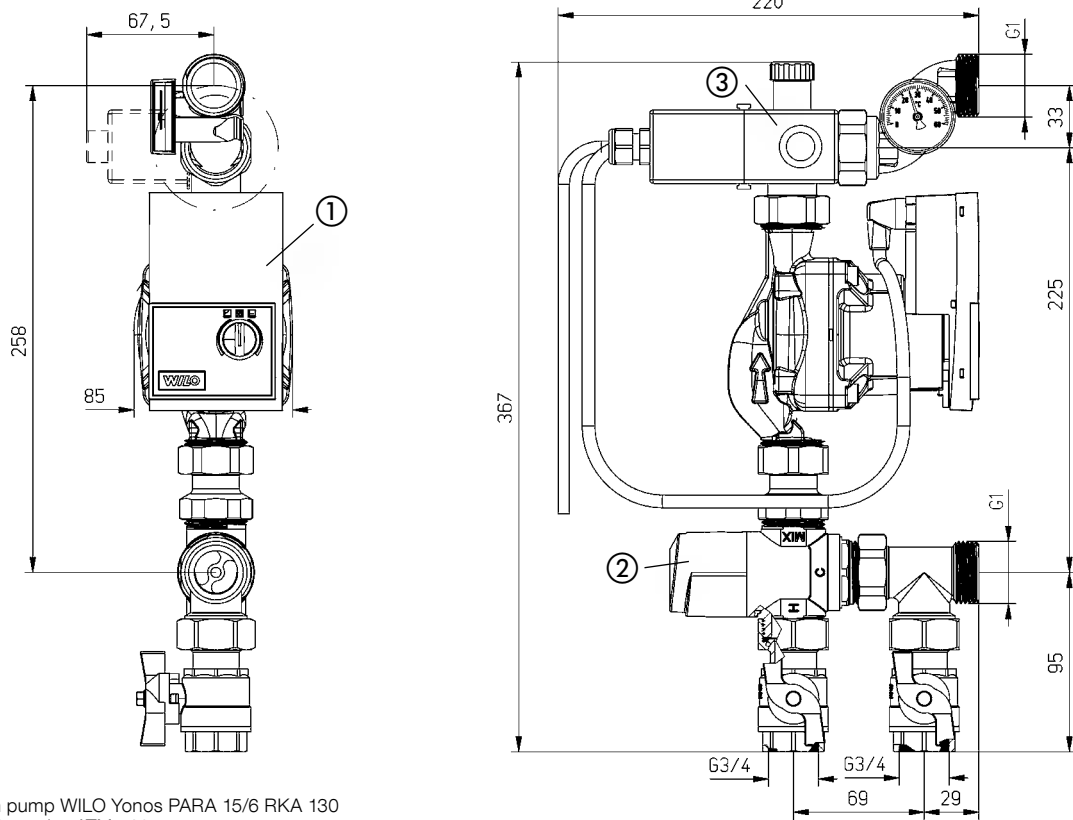

- ① Circulation pump WILO Yonos PARA 15/6 RKA 130
- ② 3-way mixing valve ATM 563
- ③ Safety temperature limiter with thermometer and de-aeration unit

OEM manifold systems ProCalida® for heating/cooling and geothermal applications

AFRISO has been manufacturing complex plastic manifolds for leading global vendors of floor heating, cooling and geothermal systems since 1981. The know-how, together with our exceptionally high degree of vertical integration including our own tool design allows us to implement even complex geometries to customer specifications.

High-grade plastic materials enable a great variety of technical fea-

tures and optimum, practical designs. Plastic valves are not susceptible to corrosion and deposits. Thermometers, shut-off valves, vents and flow meters are easy to integrate. Our offering is complemented by a comprehensive range of accessories. For decades, experts from the fields of heating, ventilation and air conditioning have been working with AFRISO products under the brands of leading system providers.

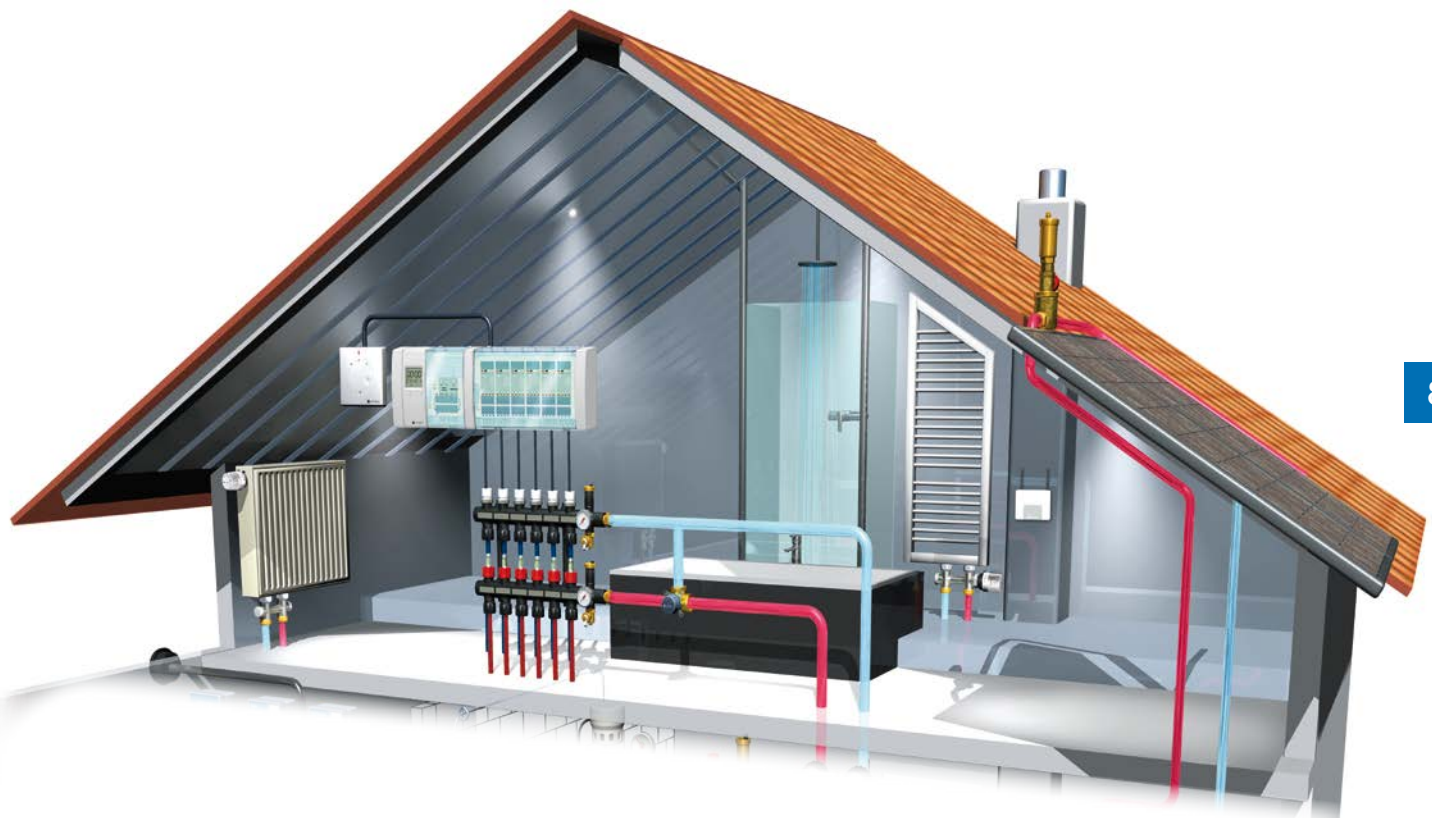

8

Advantages – your benefits

- Complex, customised manifold systems made of high-grade plastic materials proven over many years
- For heating, cooling and geothermal systems
- Numerous combinations in terms of type and number of heating circuits
- Pre-assembled, tightness-tested and ready to be connected
- Excellent insulation properties (low heat emission and noise transmission; suppression of condensate)
- Corrosion-resistant for long service life
- Vast array of versions for numerous application scenarios and logistics concepts
- Can be combined with thermometers, flow meters, thermo-actuators, connection valves and many other components
- Low weight
- Simplified logistics
- Compatible control units

OEM manifold systems ProCalida® for heating/cooling and geothermal applications

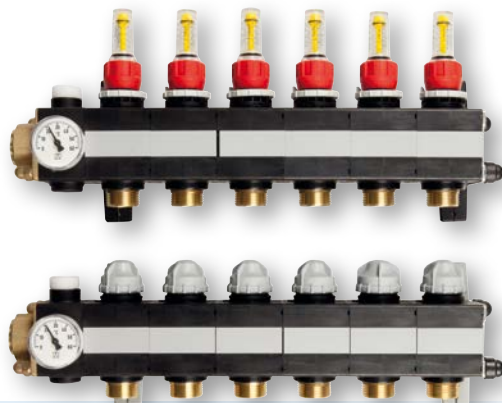

ProCalida® MC 1

Heating circuit manifold ProCalida® MC 1

Modular, very short, robust plastic heating circuit or cooling circuit manifold with up to 12 heating circuits. Return with stroke valves for actuators, flow with shut-off valves or flow meters as required. Temperature indication at flow and return lines. Main connection with union nut G1. Manual vent, filling and drain valve or quick air vent can be mounted. With dovetail guide at both ends for fast mounting to wall mounting bracket and for maximum installation flexibility.

Heating circuit

Distance: 50 mm

Connection: G $\frac{3}{4}$ eurocone

Operating temperature range

Medium: Max. 60 °C at 6 bar
or max. 90 °C at 3 bar



ProCalida® EF 1

Heating circuit manifold ProCalida® EF 1

Modular, very short plastic heating circuit or cooling circuit manifold with up to 12 heating circuits. Return with stroke valves for actuators, flow with shut-off valves or flow meters as required. Temperature indication at flow and return lines. Main connection with union nut G1. Manual vent, filling and drain valve or quick air vent can be mounted. Flexible connection from left or right as well as from the bottom with a bracket kit.

Heating circuit

Distance: 50 mm

Connection: G $\frac{3}{4}$ eurocone

Operating temperature range

Medium: Max. 60 °C at 6 bar
or max. 90 °C at 3 bar



We offer customised special products
made exactly to your requirements –
please enquire.

OEM manifold systems ProCalida® for heating/cooling and geothermal applications

Heating circuit/geothermal manifold ProCalida® IN 1½/GT 1½

Modular plastic manifold for industrial or geothermal applications with up to 20 heating circuits. Return either with stroke valves for actuators or with shut-off valves, flow either with shut-off valves or with flow meters as required. Main connection with union nut G1½. Individual installation of filling and drain valve, quick air vent, pressure gauge and thermometer via multi-way union. Easy snap-on mounting of manifold on wall bracket.

Heating circuit

Distance: 70 or 100 mm

Connection: G1 flat-sealing, compression fitting
for pipe Ø 25 x 2.3/2.5 or Ø 32 x 2.9 and Ø
40 x 3.7 or G¾ eurocone

Operating temperature range

Medium: -20/+60 °C at 6 bar



ProCalida® IN 1½

Geothermal manifold ProCalida® GT 3

Modular manifold for brine, made of plastic, for any number of heating circuits. With one shut-off valve each in the flow and return (adjusted values can be locked via a ring) and integrated flow rate indication in the return. Main circuit connection and heating circuit connections can be made to customer specifications. Individual installation of filling and drain valve, air vent and pressure gauge via cross piece. Thermometer can be integrated in the line and/or in each individual heating circuit. Robust, easy-to-mount wall bracket.

Heating circuit

Distance: 80, 90, 100, 110, 130, 140, 150 or 160 mm

Connection:

Compression fitting for pipe Ø 25 x 2.3/2.5 mm
or Ø 32 x 2.9 mm and Ø 40 x 3.7 mm;

Customer-specific versions are also available
Individual heating circuits can be rotated by 360°

Operating temperature range

Medium: -20/+60 °C at 6 bar

Range (flow meter)

2–12 l/min, 5–42 l/min, 35–70 l/min, 60–125 l/min



ProCalida® GT 3

Drinking water manifold

Plastic drinking water manifold with 3, 4, 6 or 8 drinking water connections. Triple and quadruple versions also available in H shape (both ends). Another manifold can be connected to the outlet end.

Drinking water connections

Distance: 45 mm

Connection: PEX hose ½"

Inlet: ¾" or 1" PEX pipe

Outlet: ¾" or 1" PEX pipe, blind

Operating temperature range

Medium: max. 100 °C at 10 bar



Drinking water manifold



Measuring instruments for hydraulic balancing



Combination blocks



Radiator valves

Valves and control technology for radiators and hydraulic balancing

OVERVIEW

Valves and control technology for radiators and hydraulic balancing at a glance	238
Information on hydraulic balancing	240
Automatic hydraulic balancing: Vario-DP	244
Hydraulic balancing with measuring: VarioQ	245

HYDRAULIC BALANCING

Apps AFRISO TOOLBOX and EuroSoft live for hydraulic balancing	246
CAPBs® set valve balancing for measurement of radiator valves	248
CAPBs® set line balancing for measurement of line fittings and line valves	249
Thermostat valve bodies VarioQ , adjustable, with measuring function (measurable balancing)	250
Radiator lockshield valves type 454Q , with measuring function	253
Combination blocks VarioQ-Kombi , adjustable, with measuring function	255
Screw fittings with measuring function Q	257
Dynamic thermostat valve bodies Vario-DP , adjustable (automatic balancing)	258
Thermostat combination blocks Vario THK Vario-DP , adjustable (automatic balancing)	261
Combination blocks 456-DP , adjustable (automatic balancing)	263
Flow values and valve adjustment table Vario-DP	265

RADIATOR CONNECTION

Thermostat valve bodies Vario Vario , adjustable	266
Radiator lockshield valves type 456	269
Thermostat combination blocks Vario THK , adjustable	271
Accessories for thermostat valves, combination blocks and lockshield valves	273
Thermostat control heads	274
Adapters and conversion information thermostat control heads form year of manufacture 1975	279

Valves and control technology for radiators and hydraulic balancing at a glance

						
		Vario	Vario-DP	VarioQ	Type 456	Type 454Q
		Thermostat valve bodies			Radiator lockshield valves	
Radiators	Application areas	•	•	•	•	•
Underfloor/panel heating systems		•	•	•	•	•
Refrigeration/air conditioning		•	•	•	•	•
Hydraulic Balancing		•	•	•	•	•
Vario	Control insert	•	•	•		
Adjustment spindle					•	
Water volume adjustment range		12–250 l/h or 55–350 l/h*	20–340 l/h	6–80 l/h, 14–240 l/h or 39–300 l/h*	405 l/h	120 l/h or 330 l/h*
Measuring function	Functions			•		•
Adjustable		•	•	•	•	
Can be shut off		•	•	•	•	•
Can be drained		•		•	•	•
Replaceable insert		•	•	•	•	•
Dimension (DN)	Connection	10–20	10–20	10–20	10–25	10–15
Thread		•	•	•	•	•
Screw connection		•	•	•	•	•
Thermostat head	Control / drive	•	•	•		
Thermostatic actuator 24 V, 230 V, 0–10 V		•	•	•		
Motor-driven actuator		•	•	•		
* Depends on product version.		 Page 266	 Page 258	 Page 250	 Page 269	 Page 253

i

Technical specifications, application areas and suitability depend on the product version. See catalogue data sheet and/or operating instructions for options and details.



Vario THK



Vario-DP Kombi



456-DP



VarioQ-Kombi



Q

Combination blocks				Screw fittings with measuring function
•	•	•	•	
				•
				•
•	•	•	•	•
•	•	•		
			•	
6-95 l/h or 12-215 l/h*	20-340 l/h	20-340 l/h	79 l/h or 185 l/h*	330 l/h or 900 l/h*
			•	•
•	•	•	•	
•	•	•	•	
•	•	•	•	
•	•	•	•	
15	15	15	15	15
•	•	•	•	•
•	•	•	•	•
•	•			
•	•			
Page 271	Page 261	Page 263	Page 255	Page 257

Valves and control technology for radiators and hydraulic balancing

AFRISO offers a broad range of proven products comprising standard valve bodies with suitable thermostat control heads and lockshield valves, combination blocks for compact radiators and adjustable radiator with measuring function for optimising existing heating systems and hydraulic balancing. Convincing solutions are also available for automatic hydraulic balancing with pressure-independent dynamic radiator valves.

GAMPPER Armaturen has been a member of the AFRISO group since 2012, contributing professional control technology and clever solutions for HVAC professionals to our product range. The brand GAMPPER has been a synonym for radiator fittings "Made in Germany" for more than 75 years.



Our comprehensive experience in the areas of domestic technology and building equipment and automation results from single-family home projects all the way to large-scale reference projects. GAMPPER assists planners with full-scale engineering in large projects: engineering data (such as VDI 3805 records), plant engineering or transparent project logistics via HVAC wholesalers. The OEM business covers the entire range from custom-specific development to production at the Alsenz site. Decades of cooperation in associations and institutions working on and preparing standards and legislation ensure that our products are state-of-the-art.

Gampper is:

- The first manufacturer who used virtually maintenance-free O rings instead of high-maintenance packings to seal the valve spindle of manual valves.
- The inventor of the radiator lockshield valve that can be shut off, adjusted and drained.
- The first manufacturer of thermostat valves to receive the top grade for control performance from "Stiftung Warentest", the renowned, independent German consumer organisation.
- The inventor of the patented, adjustable radiator thermostat valves VarioQ with measuring function that allow hydraulic balancing of existing heating, refrigeration and air conditioning systems.
- Numerous other innovations attesting to global success: patents for tap blocks and combination blocks for valve radiators or combined thermostat valves with integrated return temperature limiter for bathroom radiators and underfloor heating systems.

9

Patented thermostat valve VarioQ with fixed, calibrated orifice plate for high-precision adjustment of radiators.

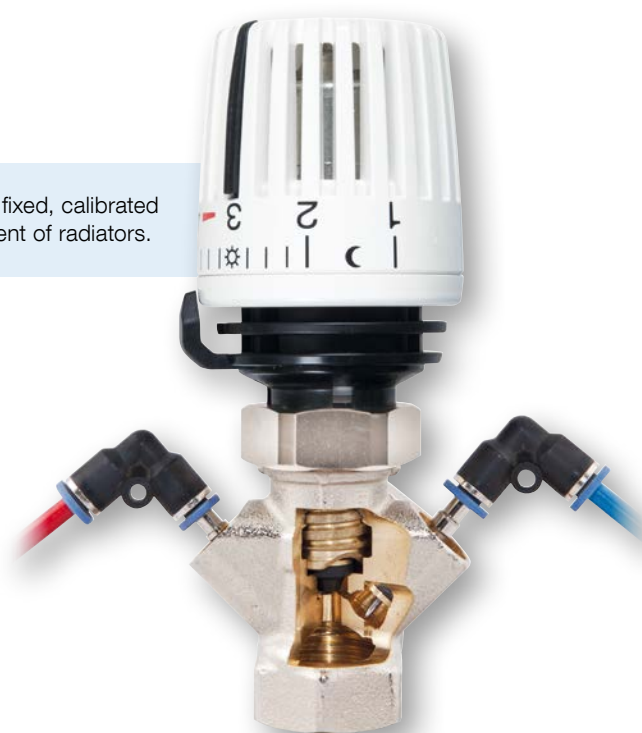



9

Solutions for hydraulic balancing of existing systems:

- 1 Compact radiator with thermostat control head 323 and adjustable combination block VarioQ-Kombi with measuring function
- 2 Manifold system ProCalida® for underfloor heating system with screw fitting with measuring function Q
- 3 Valve radiator with adjustable thermostat valve body with measuring function VarioQ, thermostat control head 323 KH and radiator lockshield valve type 456

Hydraulic balancing: Highest efficiency, maximum energy saving and comfort

Has your heating system been balanced?

On its way to the radiators and back to the boiler, the hot water flow always chooses the path of least resistance. Due to this natural law, in heating systems without hydraulic balancing radiators further away from the pump are supplied with insufficient amounts of hot water while radiators close to the pump receive too much

hot water. Typical countermeasures such as increased pump capacities or higher flow temperatures do not improve this situation, but rather amplify the negative effects. Such systems consume much more energy than necessary without providing the expected convenience.

Consequences of lack of hydraulic balancing:

- Uneven heat release
- Heating times of rooms/apartments differ
- Thermostat valves cannot properly control the room temperature
- Limited frost protection
- Disturbing flow noise in valves and pipes
- Excessive power consumption due to oversized and/or incorrectly set circulation pumps
- High losses when the heating system starts or is not used
- Low efficiency of condensing systems: Excessive flow through radiators close to the pump leads to high return temperatures and reduces the condensation effect (energy recovery during condensation of the flue gas)



9

What is hydraulic balancing?

Hydraulic balancing ensures optimum distribution of the water in the heating system. Based on the actual heat requirements of the building, the circulation pump, the control (flow temperature), the fittings and the valves are adjusted to change the volume flow in the pipes in such a way as to obtain the required flow resistance

for all radiators. This forces the hot water to flow through the system exactly as required. The right method and suitable components allow for considerable savings. In individual cases, this may amount to as much as 15% and more of the annual heating capacity.

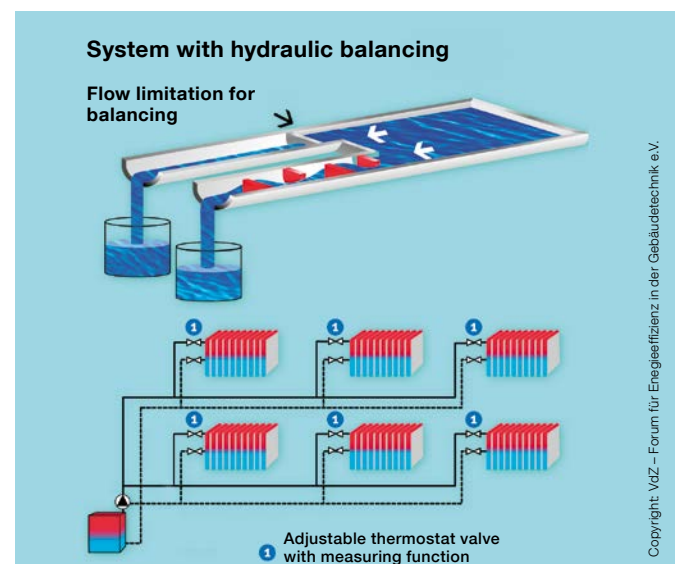
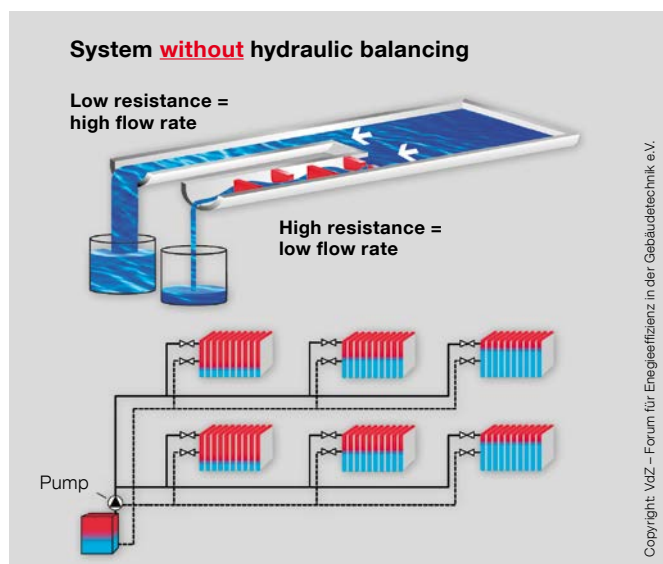



Advantages – your benefits

- + Convenience: Rooms are heated evenly
- + Radiators respond quickly to new thermostat valve settings
- + Maximum frost protection safety
- + No flow noise in the heating system
- + Heating system/pump operate with maximum efficiency to save energy
- + Increased system reliability
- + Improved energetic quality of the building
- + Reduced energy consumption saves money and protects the environment due to less emission

Legal obligations hydraulic balancing

In Germany, hydraulic balancing is mandatory, as stipulated by the German VOB, part C (German Construction Contract Procedures), and DIN 18380. The German EnEV (Energy Savings Ordinance) also requires hydraulic balancing for all new and renovated heating systems.



Fast and easy hydraulic balancing

In existing buildings, hydraulic balancing often involves a lot of estimating and approximation since precise information on the pipe system is unavailable. In old buildings, the lengths and diameters of pipes are often not sufficiently documented, the pipe systems have been changed or there are different levels of renovation. In such cases, a fundamental prerequisite is missing.

AFRISO offers two systems for hydraulic balancing. In both cases, the heating system expert adjusts the heat distribution directly at

each radiator by limiting the amount of hot water at the adjustable thermostat valves - without additional adjustment fittings. The decision as to which system is most suitable for a given building depends on a variety of factors and requirements:

Automatic hydraulic balancing for the HVAC professional

The system Vario-DP

Pre-adjustable thermostat valves Vario-DP with patented dynamic valve insert for automatic limitation of the water volume set at the valve. Vario-DP controls the water volume independent of pressure variation in the heating system. This means that Vario-DP always supplied the right water volume to the radiator, regardless of the number of open or closed thermostat valves in the system.

Your benefits:

- Automatic control of water volume
- Adjusted flow rate is not exceeded
- Building type: Primarily for single-/two-family homes, residential buildings
- Fast hydraulic balancing without measuring instrument
- Wide range of products, easy planning
- High reserve due to very wide adjustment range up to 340 l/h
- Geometry of valve insert provides protection against unwanted pollution, failure due to blocking is practically impossible



Valve range Vario-DP

The control membrane is installed directly in the valve insert and the valve spindle is used as the pressure sensor – therefore, there are no additional control components which might be subject to pollution. The valve operates with a standard valve gasket and does not require additional dirt filters.

Hydraulic balancing with measurement function for the HVAC system planner

The triple-stage VarioQ system

The pre-adjustable VarioQ thermostat valves with measurement function allow for an even more precise approach to hydraulic balancing. The triple-stage system optimises the heating system on the basis of calculation, measurement and adjustment. Thanks to an integrated, fixed orifice plate, it is possible to directly measure the current flow and adjust the calculated water volume at each radiator valve or at the lockshield valve.

Your benefits:

- Precise measurement and adjustment of the required water volume per radiator
- Building type: Primarily for public buildings, schools, administration buildings and generally for larger heating systems
- Reliable procedure for larger and complex heating systems
- Measurement option at the valve for documentable and verifiable adjustment
- Time and cost savings: Neither dynamic valves nor line fittings are required
- Up to 80 % savings with regard to pump capacity as compared to automatically balanced heating systems
- Further optimisation potential due to, for example, fewer burner starts or increased condensing effect

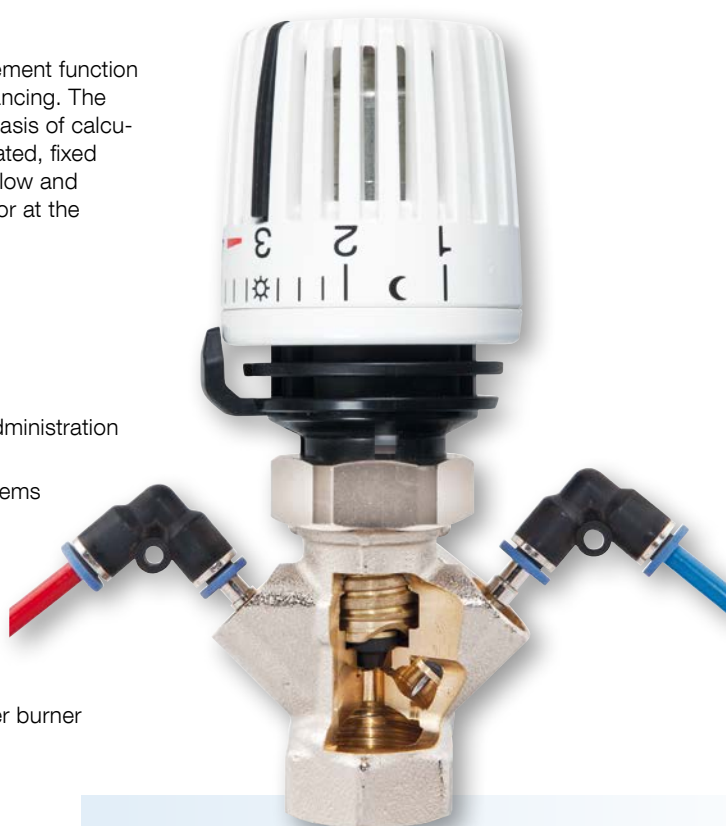

Valve range VarioQ

The fixed orifice plate of VarioQ allows for the precise adjustment of the water volume at the valve of the radiator. The pre-adjustable thermostat valves feature a fixed, calibrated orifice plate for adjustment of the volume flow directly at the valve.



EuroSoft live Applet Hydraulic Balancing

Free iOS and Android app for measurement and adjustment of radiator valves VarioQ and line fitting during hydraulic balancing. All AFRISO VarioQ valves can be directly selected. Building data and customer data can be entered within the app and users will get a measurement record in PDF format.



Measuring instrument CAPBs® set valve balancing

PT 85 measures the flow rate in litres per hour and the required water volume determined via the app can be easily set at the valve without conversion.

App EuroSoft live – Applet hydraulic balancing

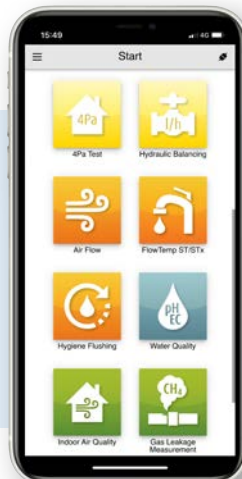
- Free iOS and Android app for measurement and adjustment of radiator valves and line fitting during hydraulic balancing
- AFRISO valves can be directly selected – third-party valves can be measured after Kvs flow coefficient Kvs has been entered
- Menu-guided measuring procedure
- Building data and customer data can be entered
- Measurement records in PDF format



Application The applet hydraulic balancing is the free in-app for measurements with the AFRISO CAPBs® sets valve balancing and line balancing.

Description With the applet hydraulic balancing, the app EuroSoft live allows for easy, menu-guided measurement of the volume flow directly at the valve of the heating surface. The AFRISO valve data stored in the applet facilitate the measuring process. In conjunction with the CAPBs® sets for hydraulic balancing, an intuitive and smart measuring system is created. Individual inspection measurements as well as a complete hydraulic balancing procedure can be carried out quickly and easily. Comment fields, photograph attachments and the signature function complete the final PDF documentation. With the familiar smartphone or tablet functions, the measurement reports can be processed or shared in a matter of seconds.

- Functions**
- "Step by step" instructions
 - Selection of measurable AFRISO radiator valves and lockshield valves
 - Creation of valves and line fittings based on valve type, design and flow coefficient Kvs
 - Flow measurement and adjustment of the required volume flows in l/h
 - PDF record with valve adjustment value, comment, photograph and customer signature
 - Export and sharing via e-mail or messengers

9

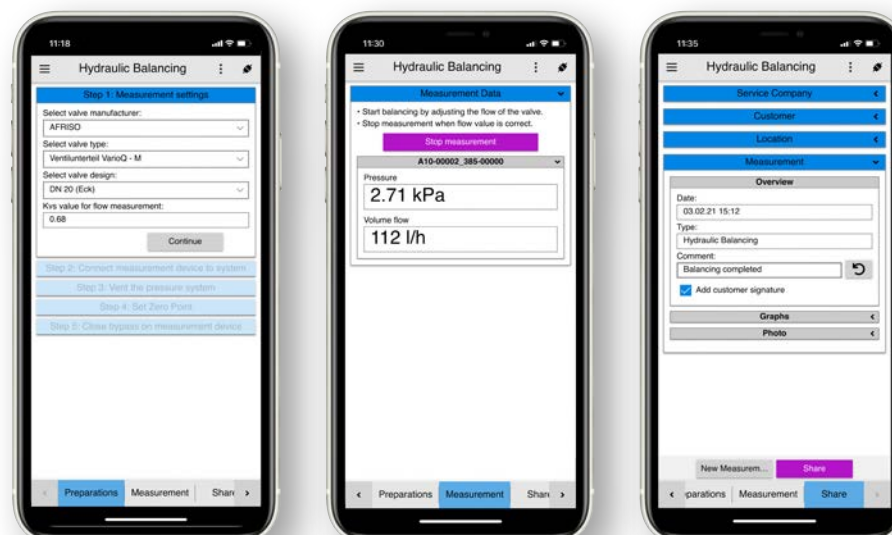

Thermostat valve bodies

VarioQ



- Fixed, calibrated orifice plate for accurate adjustment of the radiator
- Fully adjustable
- Valve insert can be replaced without system having to be drained
- Lightning-fast hydraulic balancing with CAPBs® set valve balancing



Application For measuring and adjusting the volume flow directly at the valve, e.g. with the CAPBs® set valve balancing as measuring instrument for hydraulic balancing. Suitable for small, medium and large water volumes. For installation in dual-pipe heating systems. Design as per standard, therefore, installation in existing systems without changes to the connection pipes.

Description Patented, low-noise thermostat valve body with fixed, calibrated orifice plate for measuring and adjusting the volume flow directly at the valve. Mounting cap with valve shut-off function. Threaded connection M30 x 1.5 mm for thermostat control heads and actuators. Fully adjustable with ES-SV adjustment key. Valve spindle with double O ring seal. The valve insert can be replaced with the MGV mounting unit at operating pressure without the system having to be drained.

VarioQ is a triple-stage hydraulic balancing system which allows for optimisation of the heating pipe system by means of calculation, measurement and adjustment. The CAPBs® set valve balancing (measuring instrument) measures the flow rate in litres per hour and the water volume can be easily set at the valve without conversion. Even minimum flow rates can be set with this system.

Technical specifications

System connection

See ordering table

Thermostat head/actuator connection

Threaded connection M30 x 1.5 mm

Setting range

VarioQ S: 6–80 l/h

VarioQ M: 14–215 l/h

VarioQ L: 39–300 l/h

Nominal pressure

Max. 10 bar

Nominal diameter

DN 10, DN 15, DN 20

Operating temperature range

Medium: $T_{max} = 120\text{ °C}$

Housing

VarioQ S–L: Brass, nickel-plated

Option

- Version PN 16

Measuring points volume flow – VarioQ section

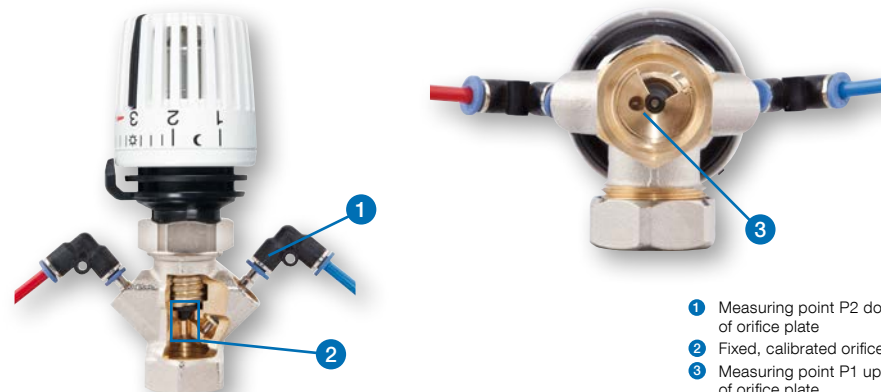

- 1 Measuring point P2 downstream of orifice plate
- 2 Fixed, calibrated orifice plate
- 3 Measuring point P1 upstream of orifice plate

i

In the case of axial version or angled-angled version (left/right), use valve body Vario (axial) or Vario angled-angled (left/right) with lockshield valve with measuring function 454 Q.

See page 252 for prices.
See page 273 for accessories.

Thermostat valve bodies VarioQ

Valve pre-adjustment VarioQ thermostat valves are fully adjustable by means of the ES-SV adjustment key, starting with the open position (8 = open); the numbers 1–8 are shown on the adjustment key. Mark and counter-mark are aligned. Each 1/8 of a turn corresponds to one flow characteristic, shown in a diagram (see operating instructions).

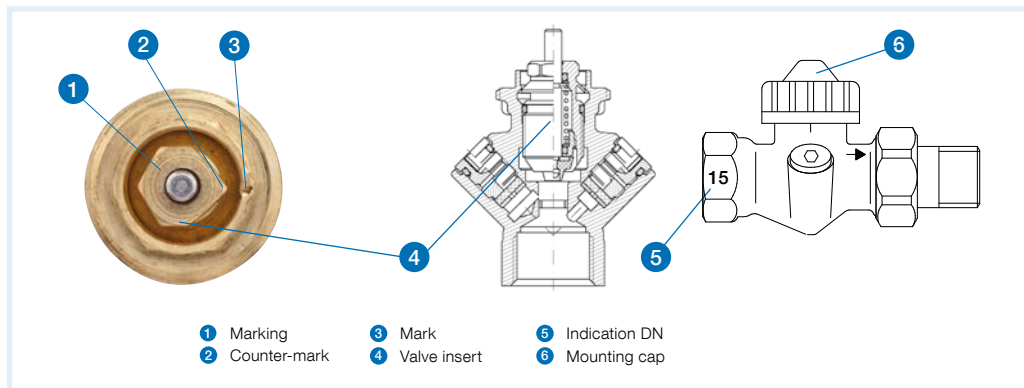

Type overview

Valve type	Marking at valve insert	Colour of mounting cap	Flow rate range in l/h*	
			Min.	Max.
VarioQ S	1 ring/red	Red	6	80
VarioQ M	2 rings	Black	20	260
VarioQ L	3 rings/green	Green	20	400

* The measurable flow rate is much higher than the adjustable range of the valves. The flow rate ranges for the VarioQ valves are shown in the ordering table.



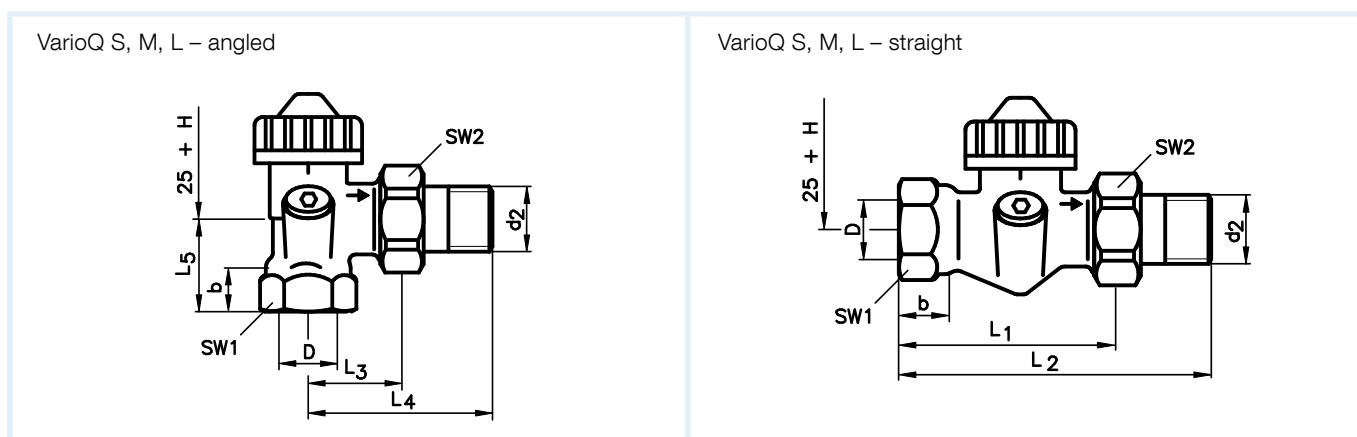





Types and dimensions as per EN 215, series D



Dimensions (mm) VarioQ S, M, L

DN	D	d1	d2	Spanner size SW1	Spanner size SW2	H	b min	L1 ±2	L2 ±2	L3 ±1	L4 ±1.5	L5 ±1.5	L6	L7	L8
10	Rp $\frac{3}{8}$	-	R $\frac{3}{8}$	22	27	= Height control-head	10.1	59	85	26	52	22	74	26	40
15	Rp $\frac{1}{2}$	G $\frac{3}{4}$	R $\frac{1}{2}$	27	30		13.2	66	95	29	58	26	82	29	42
20	Rp $\frac{3}{4}$	-	R $\frac{3}{4}$	32	37		14.5	74	106	34	66	29	96	34	53

Thermostat valve bodies VarioQ

DG: V, PG: 2	Version	Nominal diameter	Connection	Flow coefficient* (m ³ /h)	Flow coefficient Kvs** (m ³ /h)			Part no.	Price €
VarioQ S for small water volumes									
	Angled	DN 10	Rp ³ / ₈ x R ³ / ₈	0.019–0.24	0.25	1	35	181 110.101	
		DN 15	Rp ¹ / ₂ x R ¹ / ₂			1	30	181 120.101	
		DN 20	Rp ³ / ₄ x R ³ / ₄			1	25	181 130.101	
	Straight	DN 10	Rp ³ / ₈ x R ³ / ₈	0.019–0.24	0.25	1	35	181 160.101	
		DN 15	Rp ¹ / ₂ x R ¹ / ₂			1	30	181 170.101	
		DN 20	Rp ³ / ₄ x R ³ / ₄			1	25	181 180.101	
VarioQ M for medium water volumes									
	Angled	DN 10	Rp ³ / ₈ x R ³ / ₈	0.044–0.46	0.68	1	35	181 210.101	
		DN 15	Rp ¹ / ₂ x R ¹ / ₂			1	30	181 220.101	
		DN 20	Rp ³ / ₄ x R ³ / ₄			1	25	181 230.101	
	Straight	DN 10	Rp ³ / ₈ x R ³ / ₈	0.044–0.46	0.68	1	35	181 260.101	
		DN 15	Rp ¹ / ₂ x R ¹ / ₂			1	30	181 270.101	
		DN 20	Rp ³ / ₄ x R ³ / ₄			1	25	181 280.101	
VarioQ L for large water volumes									
	Angled	DN 10	Rp ³ / ₈ x R ³ / ₈	0.125–0.51	0.94	1	-	181 310.101	
		DN 15	Rp ¹ / ₂ x R ¹ / ₂			1	-	181 320.101	
		DN 20	Rp ³ / ₄ x R ³ / ₄			1	-	181 330.101	
	Straight	DN 10	Rp ³ / ₈ x R ³ / ₈	0.125–0.51	0.94	1	-	181 360.101	
		DN 15	Rp ¹ / ₂ x R ¹ / ₂			1	-	181 370.101	
		DN 20	Rp ³ / ₄ x R ³ / ₄			1	-	181 380.101	

* The flow coefficient corresponds to the water flow in m³/h through the valve at a given valve stroke (proportional offset, e.g. 1 K or 2 K) and a differential pressure of 1 bar.

** The flow coefficient Kvs is the flow coefficient of the valve at nominal stroke (100 % open).

*** Extra charge added to standard version in €. Replace the specified digit in the standard part number with this number when ordering.

Radiator lockshield valves type 454Q



- Fixed, calibrated orifice plate for accurate adjustment of the radiator
- Individual radiators can be shut off without the heating system having to be drained
- Lightning-fast hydraulic balancing with CAPBs® set valve balancing



Application For measuring the volume flow directly at the screw fitting, e.g. with the CAPBs® set valve balancing for hydraulic balancing. Suitable for small and medium water volumes. For installation in single-pipe and dual-pipe heating systems. Adjustments are made e.g. via the adjustable dynamic thermostat valve Vario-DP in the flow.

Description Radiator lockshield valve with measuring function type 454Q with drain and adjustment function. Measurement via an integrated, fixed and calibrated orifice plate. With cap to protect against incorrect operation. The optional filling and draining unit FEV 03 with hose connection 1/2" can be used for easy and fast draining.

The radiator lockshield valve is a part of the product range for the triple-stage balancing system VarioQ which allows for optimisation of the heating pipe system by means of calculation, measurement and adjustment. The CAPBs® set valve balancing (measuring instrument) measures the flow rate in litres per hour. Even minimum flow rates can be set with this system.

Technical specifications

System connection

See ordering table

Adjustment range at 10 kPa

454 Q S: 120 l/h

454 Q M: 330 l/h

Nominal pressure

Max. 10 bar

Nominal diameter

DN 10, DN 15

Operating temperature range

Medium: $T_{max} = 120\text{ °C}$

Housing

Gunmetal, nickel-plated

Types and dimensions (mm) as per DIN 3842

Type 454Q S, M – angled

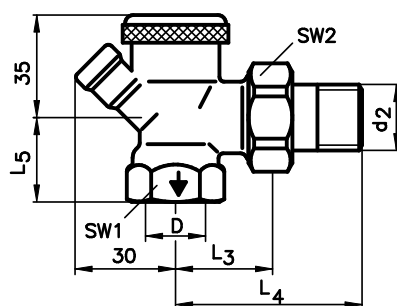

Type 454Q S, M – straight

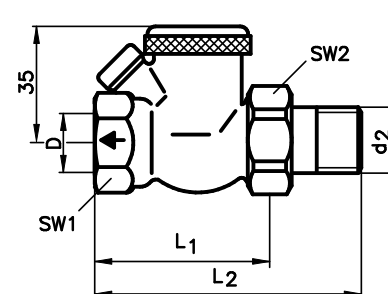

i







Please use valve body to adjust the water volume.

See page 254 for prices.
See page 273 for accessories.

Dimensions (mm)

DN	D	d2	Spanner size SW1	Spanner size SW2	L1 ±2	L2 ±2	L3 ±1	L4 ±1.5	L5 ±1.5
10	Rp3/8	R3/8	22	27	49	75	26	52	22
15	Rp1/2	R1/2	27	30	51	80	29	58	26

Radiator lockshield valves type 454Q

DG: V, PG: 2	Version	Nominal diameter	Connection	Flow coefficient Kvs* (m ³ /h)			Part no.	Price €
454Q S for small water volumes, measuring range 20–400 l/h								
	Angled	DN 10	Rp ³ / ₈ x R ³ / ₈	0.38	1	-	479 011	
		DN 15	Rp ¹ / ₂ x R ¹ / ₂	0.38	1	40	479 021	
	Straight	DN 10	Rp ³ / ₈ x R ³ / ₈	0.38	1	-	479 061	
		DN 15	Rp ¹ / ₂ x R ¹ / ₂	0.38	1	40	479 071	
454Q M for medium water volumes, measuring range 20–400 l/h								
	Angled	DN 10	Rp ³ / ₈ x R ³ / ₈	1.04	1	-	479 012	
		DN 15	Rp ¹ / ₂ x R ¹ / ₂	1.04	1	40	479 022	
	Straight	DN 10	Rp ³ / ₈ x R ³ / ₈	1.04	1	-	479 062	
		DN 15	Rp ¹ / ₂ x R ¹ / ₂	1.04	1	40	479 072	

* The flow coefficient corresponds to the water flow in m³/h through the valve at a given valve stroke (proportional offset e.g. 1 K or 2 K) and a differential pressure of 1 bar. The flow coefficient Kvs is the flow coefficient of the valve at nominal stroke (100 % open).

Combination blocks VarioQ-Kombi for compact radiators with valve



- Fixed, calibrated orifice plate for accurate adjustment of the radiator
- Hydraulic balancing CAPBs® set valve balancing
- For wall or floor connection, also suitable for baseboard heating systems

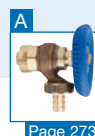

Application For measuring the volume flow directly at the radiator, e.g. with the CAPBs® set valve balancing as measuring instrument for hydraulic balancing. Suitable for small and medium water volumes. For connection to compact radiators with valve with an axis distance of 50 mm in dual-pipe heating systems. Adjustments are made either via the adjustable valve insert in the compact radiator or via the VarioQ combination block.

Description Adjustable combination block with measuring function VarioQ-Kombi with drain and shut-off feature. The volume flow is measured via an integrated, fixed and calibrated orifice plate. With cap to protect against incorrect operation.

VarioQ-Kombi is a part of the product range for the triple-stage balancing system VarioQ which allows for optimisation of the heating pipe system by means of calculation, measurement and adjustment. The CAPBs® set valve balancing as measuring instrument measures the flow rate in litres per hour. Even minimum flow rates can be set with this system.

Technical specifications

System connection (valve radiators)

G $\frac{3}{4}$ eurocone or G $\frac{1}{2}$ female thread

Adjustment range at 10 kPa

Vario Q-Kombi S: 79 l/h

Vario Q-Kombi M: 185 l/h

Nominal pressure

Max. 10 bar

Nominal diameter

DN 15

Operating temperature range

Medium: T_{max} = 120 °C

Housing

Gunmetal, nickel-plated







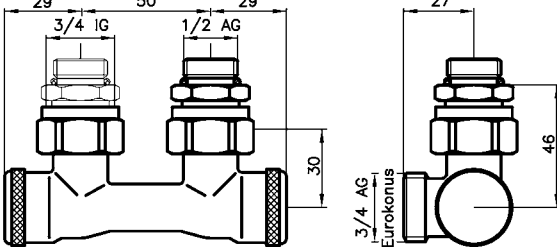
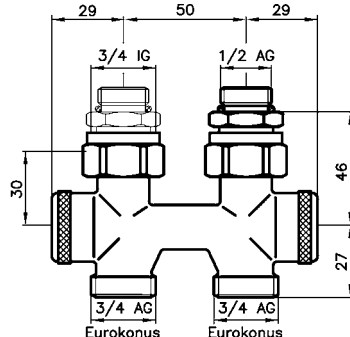
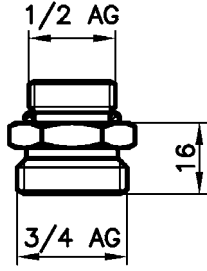

See page 273 for accessories.

Combination blocks VarioQ-Kombi for compact radiators with valve

Types and dimensions (mm)

<p>VarioQ-Kombi S, M – angled</p> 	<p>VarioQ-Kombi S, M – straight</p> 
<p>Adapter for radiators with R$\frac{1}{2}$ female thread</p> 	

9

DG: V, PG: 2	Version	Nominal diameter	Radiator connection	Flow coefficient* (m ³ /h)			Part no.	Price €
VarioQ-Kombi S for small water volumes								
	Angled	DN 15	G $\frac{1}{2}$ female thread	0.25	1	-	423 821	
	Straight	DN 15	G $\frac{1}{2}$ female thread	0.25	1	-	423 871	
VarioQ-Kombi M for medium water volumes								
	Angled	DN 15	G $\frac{1}{2}$ female thread	0.585	1	-	423 621	
	Straight	DN 15	G $\frac{1}{2}$ female thread	0.585	1	-	423 671	

* The flow coefficient corresponds to the water flow in m³/h through the valve at a given valve stroke (proportional offset, e.g. 1 K or 2 K) and a differential pressure of 1 bar.

Screw fittings with measuring function Q



- Measuring insert with fixed, calibrated orifice plate
- Ideal for hydraulic balancing of underfloor/heating circuit manifolds in existing buildings



Application For measuring the volume flow, e.g. with the CAPBs® set valve balancing as measuring instrument for hydraulic balancing. The screw connection with measuring is ideal for underfloor heating manifolds/ heating circuit manifolds.

Description Compact screw fitting with measuring function, straight design, with fixed calibrated orifice plate for measuring the volume flow.

The optimum volume flow is to be determined by means of a heating load calculation program and can then be directly measured and adjusted with the CAPBs® set valve balancing. Adjustments are made via standard adjustment valves.

Technical specifications

System connection

See ordering table

Adjustment range at 10 kPa

Q M: 330 l/h

Q, L_{max}: 900 l/h

Nominal pressure

M, L_{max}: Max. 16 bar

Nominal diameter

DN 15





Operating temperature range

Medium: T_{max} = 120 °C

Housing

M, L_{max}: Gunmetal

9

DG: V, PG: 2	Version	Nominal diameter	Flow rate range (m ³ /h)	Flow coefficient*			Part no	Price €
	Q M for medium water volumes, PN 16, connection G $\frac{3}{4}$ eurocone	DN 15	0.02 – 0.40	1.04	1	-	408 025	
	Q L_{max} for large water volumes PN 16, connection G $\frac{3}{4}$ eurocone	DN 15	0.06 – 1.20	2.85	1	-	408 026	

* The flow coefficient corresponds to the water flow in m³/h through the valve at a given valve stroke (proportional offset, e.g. 1 K or 2 K) and a differential pressure of 1 bar.

Dynamic thermostat valve bodies Vario-DP



- Automatic control of water volume
- Fast hydraulic balancing without calculation of pipe system and measuring instrument
- High reserve due to adjustment range up to 340 l/h
- Patented, simple valve insert provides protection against pollution



Application Suitable for small to large water volumes. For installation in dual-pipe heating systems. The dynamic valve range Vario-DP makes hydraulic balancing in single and two family homes an easy and fast job.

Description Low-noise thermostat valve body with threaded connection M30 x 1.5 mm for thermostat control heads and actuators. Mounting cap with valve shut-off function. Adjustment range 20 to 340 l/h, fully adjustable with standard heating system bleed screw key. Pre-adjustment directly readable without scale.

The patented valve insert with automatic flow limiter automatically limits the water volume adjusted at the valves, independent of pressure variation in the heating system. This means that Vario-DP always supplies the right water volume to the radiator, regardless of the number of open or closed thermostat valves in the system. The valve insert can be replaced with the MGV mounting unit at operating pressure without the system having to be drained.

Technical specifications

System connection

See ordering table

Thermostat head/actuator connection

Threaded connection M30 x 1.5 mm

Setting range

20–340 l/h

Nominal pressure

Max. 10 bar

Differential pressure (Δp)

Max. 70 kPa

Min. 15 kPa

Nominal diameter

DN 10, DN 15, DN 20

Operating temperature range

Medium: $T_{max} = 90\text{ }^{\circ}\text{C}$

Housing

Gunmetal, nickel-plated

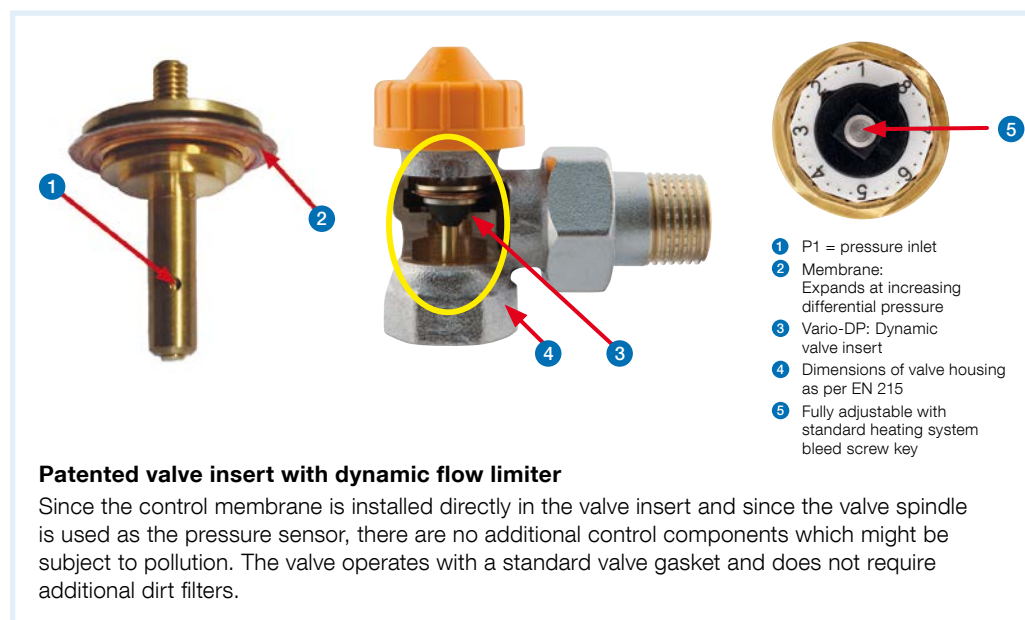

i

See page 265 for valve adjustment table (water volumes).
See page 260 for prices.
See page 271 for accessories.

Please note the additional information on mounting in the operating instructions.

Dynamic thermostat valve bodies Vario-DP

Types and dimensions (mm)

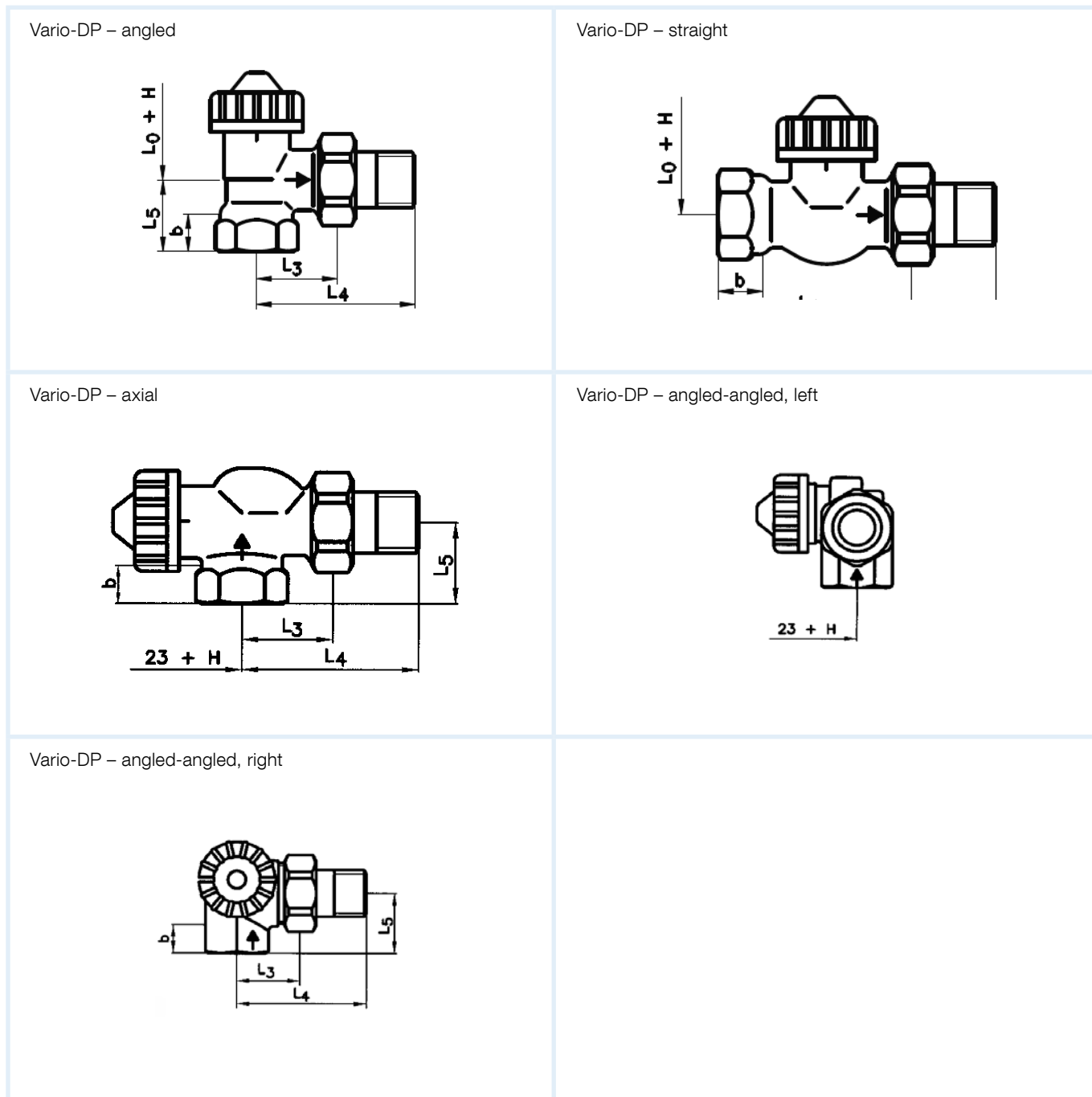





Dimensions (mm) Vario-DP

DN	D	B	L ₀	L ₁	L ₂	L ₃	L ₄	L ₅	L ₆
10	Rp ³ / ₈	10.1	23	59	85	26	52	25	-
15	Rp ¹ / ₂	13.2	23	66	95	29	58	26	55
20	Rp ³ / ₄	14.5	23	74	106	34	66	29	-

Dynamic thermostat valve bodies

Vario-DP

DG: V, PG: 2		Connection	Part no.	Prices €
Thermostat valve body Vario-DP				
	Angled	Rp $\frac{3}{8}$ x Rp $\frac{3}{8}$	161 010.100	
		Rp $\frac{1}{2}$ x Rp $\frac{1}{2}$	161 020.100	
		Rp $\frac{3}{4}$ x Rp $\frac{3}{4}$	161 030.100	
	Straight	Rp $\frac{3}{8}$ x Rp $\frac{3}{8}$	161 060.100	
		Rp $\frac{1}{2}$ x Rp $\frac{1}{2}$	161 070.100	
		Rp $\frac{3}{4}$ x Rp $\frac{3}{4}$	161 080.100	
	Axial	Rp $\frac{1}{2}$ x Rp $\frac{1}{2}$	163 020.100	
	Angled-angled, right	Rp $\frac{1}{2}$ x Rp $\frac{1}{2}$	165 020.100	
	Angled-angled, left	Rp $\frac{1}{2}$ x Rp $\frac{1}{2}$	167 020.100	

Dynamic thermostat combination blocks Vario-DP



- Automatic control of water volume
- Fast hydraulic balancing without calculation of pipe system measuring instrument
- High reserve due to adjustment range up to 340 l/h
- Patented, simple valve insert provides protection against pollution



Application Suitable for small to large water volumes. For mounting to compact or bathroom radiators with centre connection in dual-pipe heating systems. The dynamic valve range Vario-DP makes hydraulic balancing in single and two family homes an easy and fast job.

Description Thermostat combination block with threaded connection M30 x 1.5 mm for thermostat control heads and actuators. Mounting cap with valve shut-off function. Adjustment range 20–340 l/h, fully adjustable with standard heating system bleed screw key. Pre-adjustment directly readable without scale.

The patented valve insert with automatic flow limiter automatically limits the water volume adjusted at the valves, independent of pressure variation in the heating system. This means that Vario-DP always supplies the right water volume to the radiator, regardless of the number of open or closed valves in the system. The valve insert can be replaced with the MGV mounting unit at operating pressure without the system having to be drained.

Technical specifications

System connection

See ordering table

Thermostat head/actuator connection

Threaded connection M30 x 1.5 mm

Setting range

20–340 l/h

Nominal pressure

Max. 10 bar

Differential pressure (Δp)

Max. 70 kPa

Min. 15 kPa

Nominal diameter

DN 10, DN 15, DN 20

Operating temperature range

Medium: $T_{\max} = 90\text{ }^{\circ}\text{C}$

Housing

Gunmetal, nickel-plated

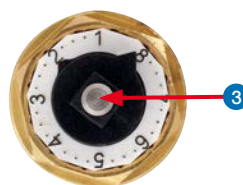
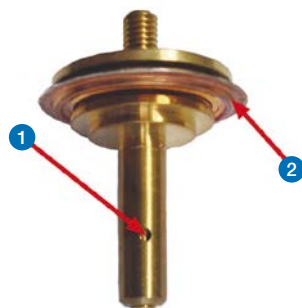

- 1 P1 = pressure inlet
- 2 Membrane:
Expands at increasing differential pressure
- 3 Fully adjustable with standard heating system bleed screw key

i

See page 265 for valve adjustment table (water volumes).
See page 262 for prices.
See page 273 for accessories.

Please note the additional information on mounting in the operating instructions.

Patented valve insert with dynamic flow limiter

Since the control membrane is installed directly in the valve insert and since the valve spindle is used as the pressure sensor, there are no additional control components which might be subject to pollution. The valve operates with a standard valve gasket and does not require additional dirt filters.

Dynamic thermostat combination blocks

Vario-DP

Types and dimensions (mm)

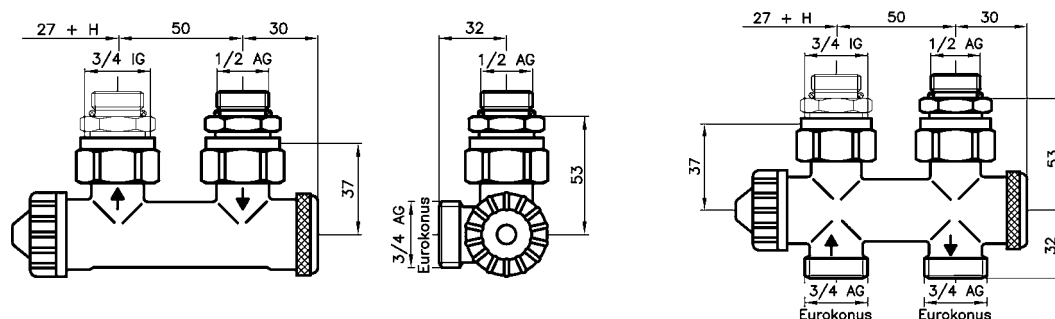

Version for compact radiators/bathroom radiators with G $\frac{1}{2}$ female thread

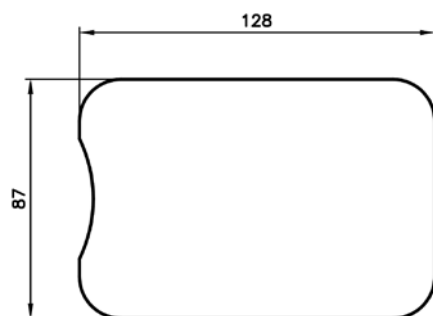

Cover



9

DG: V, PG: 2	Connection	Part no.	Prices €
Combination block Vario-DP for compact radiators/bathroom radiators with G$\frac{1}{2}$ female thread			
	Straight	G $\frac{1}{2}$ female thread	221 075.100
	Angled	R $\frac{1}{2}$ female thread	221 025.100

Dynamic combination blocks

456-DP



- Automatic control of water volume
- High reserve due to adjustment range up to 340 l/h
- Patented, simple valve insert provides protection against pollution
- Ideal for energetic renovation of older heating systems

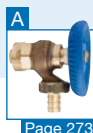

Page 273

Application Suitable for small to large water volumes. For installation in dual-pipe heating systems for consumers with integrated valve. The dynamic valve range Vario-DP makes hydraulic balancing in single and two family homes an easy and fast job.

Description Low-noise, adjustable combination block with drain and shut-off feature. Adjustment range 20 to 340 l/h, fully adjustable with standard heating system bleed screw key. With cap to protect against incorrect operation.

The patented valve insert with automatic flow limiter automatically limits the water volume adjusted at the valves, independent of pressure variation in the heating system. This means that Vario-DP always supplies the right water volume to the radiator, regardless of the number of open or closed valves in the system. The valve insert can be replaced with the MGV mounting unit at operating pressure without the system having to be drained.

Technical specifications

System connection

See ordering table

Thermostat head/actuator connection

Threaded connection M30 x 1.5 mm

Setting range

20–340 l/h

Nominal pressure

Max. 10 bar

Differential pressure (Δp)

Max. 70 kPa

Min. 15 kPa

Nominal diameter

DN 15

Operating temperature range

Medium: $T_{\max} = 90\text{ }^{\circ}\text{C}$

Housing

Gunmetal, nickel-plated

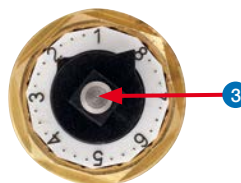
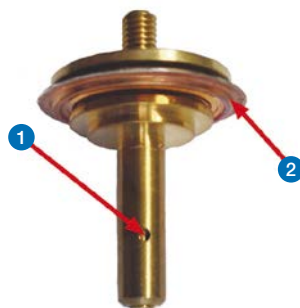

- 1 P1 = pressure inlet
- 2 Membrane: Expands at increasing differential pressure
- 3 Fully adjustable with standard heating system bleed screw key

i

See page 265 for valve adjustment table (water volumes).
See page 262 for prices.
See page 273 for accessories.

Please note the additional information on mounting in the operating instructions.

Patented valve insert with dynamic flow limiter

Since the control membrane is installed directly in the valve insert and since the valve spindle is used as the pressure sensor, there are no additional control components which might be subject to pollution. The valve operates with a standard valve gasket and does not require additional dirt filters.

Dynamic combination blocks 456-DP



Types and dimensions (mm)

456-DP, straight – version G $\frac{3}{4}$ female thread

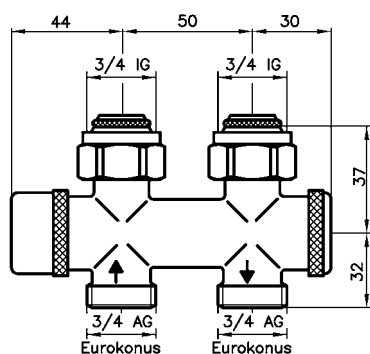

456-DP, straight – version G $\frac{1}{2}$ male thread

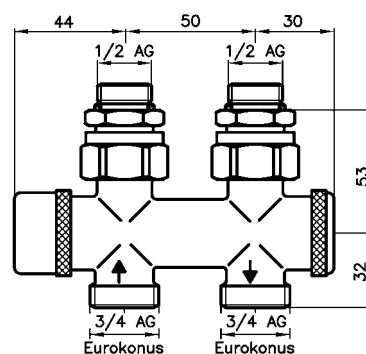



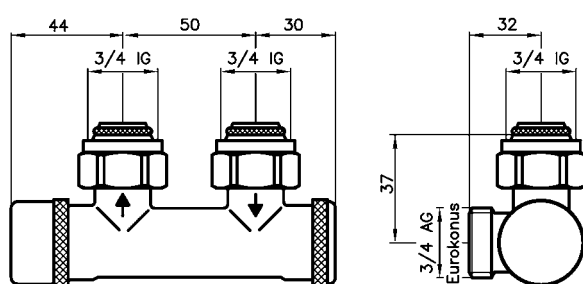

456-DP, angled – version G $\frac{3}{4}$ female thread

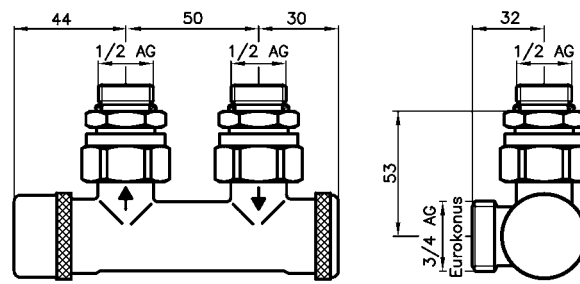

456-DP, angled – version G $\frac{1}{2}$ male thread



9

DG: V, PG: 2		Connection	Part no.	Prices €
Combination block 456-DP for compact radiators with valve with G$\frac{1}{2}$ female thread				
	Straight	G $\frac{3}{4}$ eurocone	423 070	
	Straight	G $\frac{1}{2}$ female thread	423 071	
	Angled	R $\frac{3}{4}$ eurocone	423 020	
	Angled	R $\frac{1}{2}$ female thread	423 021	

Pre-adjustment calculated water volume for Vario-DP valve bodies and combination blocks

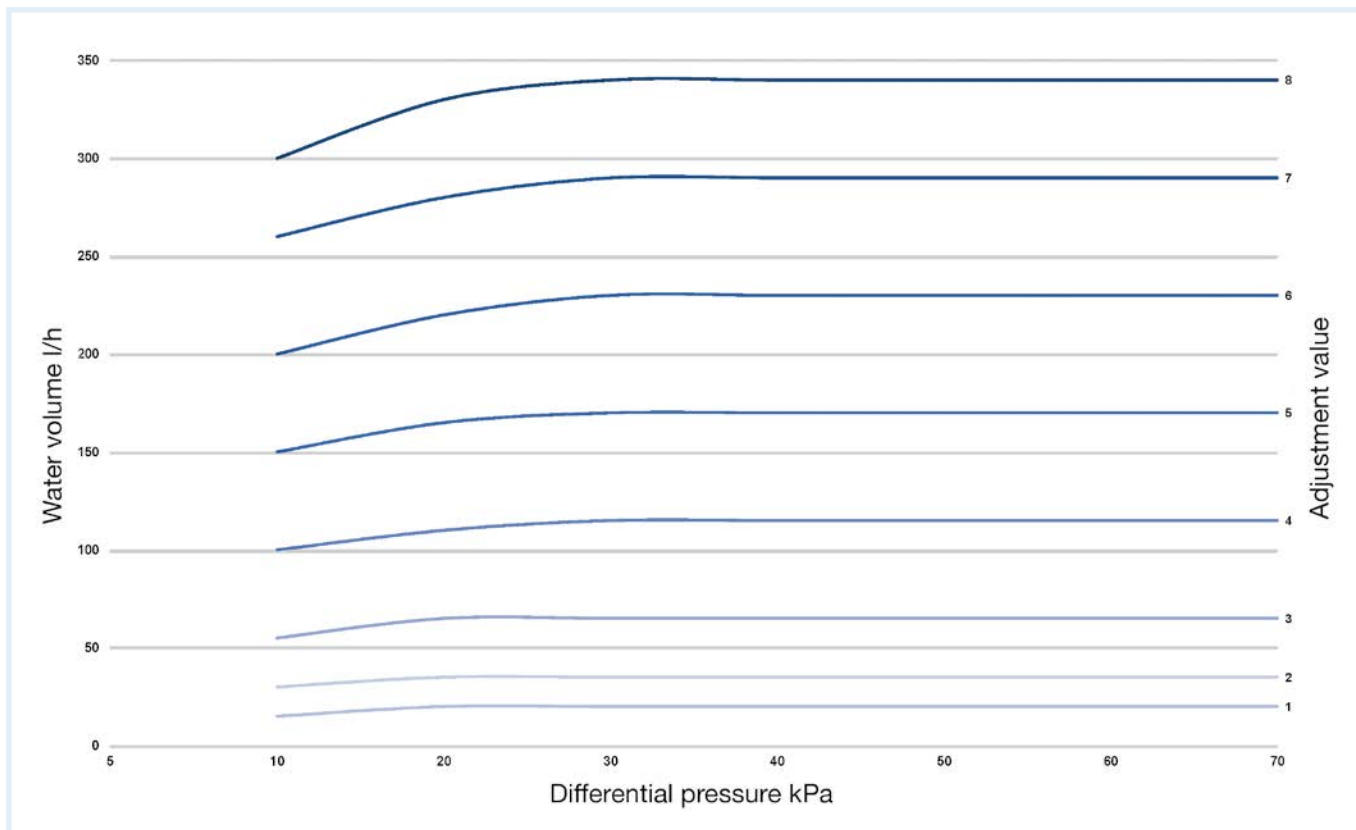

9

Adjustment table

Pre-adjustment valve:	1	1•	1••	1•••	2	2•	2••	2•••	3	3•	3••	3•••	4	4•	4••	4•••	5	5•	5••	5•••	6	6•	6••	6•••	7	7•	7••	7•••	8
	Water volume in l/h:																												
Differential pressure: 15-70 kPa	20	20	25	25	35	40	45	55	65	80	90	100	115	135	145	160	170	185	200	215	230	245	260	275	290	300	315	330	340

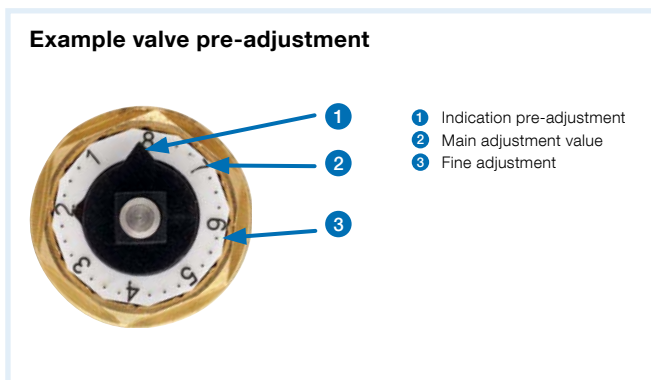

Thermostat valve bodies

Vario

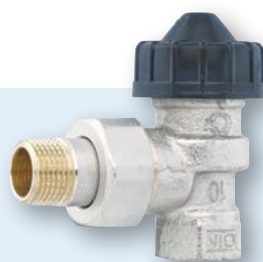

- Fully adjustable
- Valve insert can be replaced without system having to be drained
- Various versions and sizes for virtually any application

Adjustment key ES-SV



Application Suitable for medium water volumes. For installation in dual-pipe central heating systems.

Description Low-noise thermostat valve body with threaded connection M30 x 1.5 mm for thermostat control heads and actuators. Mounting cap with valve shut-off function. Fully adjustable with ES-SV adjustment key. Valve spindle with double O ring seal. The valve insert can be replaced with the MGV mounting unit at operating pressure without the system having to be drained.

Technical specifications

System connection

See ordering table

Thermostat head/actuator connection

Threaded connection M30 x 1.5 mm

Adjustment range at 10 kPa

Vario M: 12–250 l/h

Vario L: 55–350 l/h

Nominal pressure

Max. 10 bar

Nominal diameter

DN 10, DN 15, DN 20

Operating temperature range

Medium: $T_{max} = 120\text{ °C}$

Housing

Gunmetal, nickel-plated

9

Valve pre-adjustment

Vario thermostat valves are fully adjustable by means of the ES-SV adjustment key, starting with the open position (8 = open). The numbers 1–8 are shown on the adjustment key. Mark and counter-mark are aligned. Each $\frac{1}{8}$ of a turn corresponds to one flow characteristic, shown in a diagram (see operating instructions).

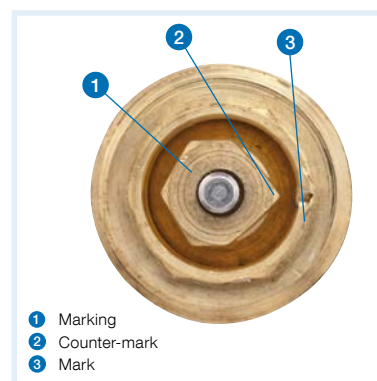

Type overview

Valve type	Marking at valve insert	Colour of mounting cap
Vario M	2 rings	Black

i

See page 268 for prices.
See page 273 for accessories.

Thermostat valve bodies

Vario

Types and dimensions as per EN 215, series D

Vario M – angled

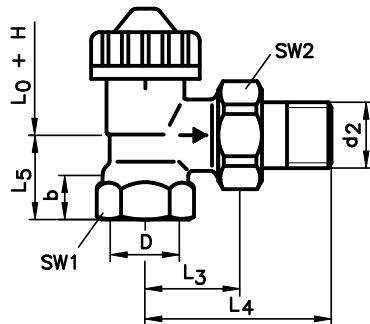

Vario M – straight

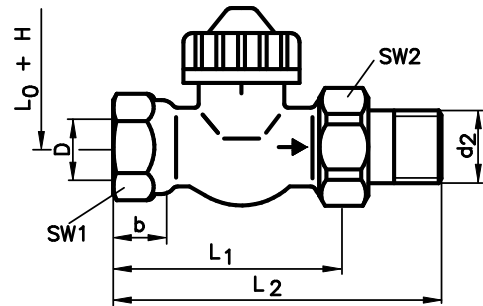

Vario M – axial

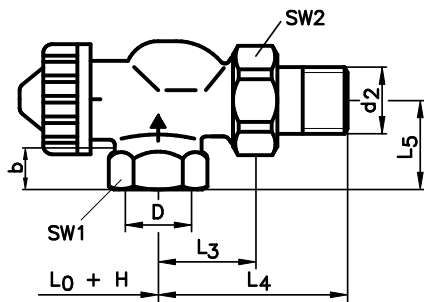

Vario M – angled-angled, left

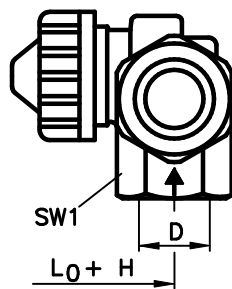

Vario M, – angled-angled, right

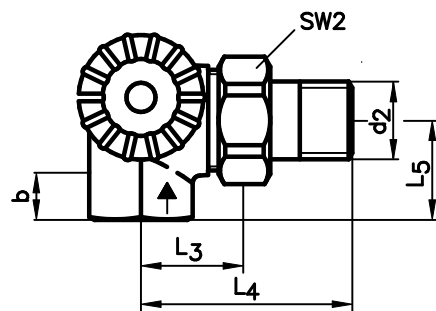







Dimensions (mm)

DN	D	d ₂	Spanner size SW ₁	Spanner size SW ₂	H	L ₀	L ₁ ±2	L ₂ ±2	L ₃ ±1	L ₄ ±1.5	L ₅ ±1.5	b min
10	Rp ³ / ₈	R ³ / ₈	22	27	= Height control head	23	59	85	26	52	22	10.1
15	Rp ¹ / ₂	R ¹ / ₂	27	30		23	66	95	29	58	26	13.2
20	Rp ³ / ₄	R ³ / ₄	32	37		23	74	106	34	66	29	14.5

Thermostat valve bodies

Vario

DG: V, PG: 2	Version	Nominal diameter	Connection	Flow coefficient* (m ³ /h)	Flow coefficient Kvs** (m ³ /h)			Part no.	Price €
Vario M for medium water volumes									
	Angled	DN 10	Rp $\frac{3}{8}$ x R $\frac{3}{8}$	0.038–0.40	0.79	1	-	141 210.101	
		DN 15	Rp $\frac{1}{2}$ x R $\frac{1}{2}$			1	40	141 220.101	
		DN 20	Rp $\frac{3}{4}$ x R $\frac{3}{4}$			1	25	141 230.101	
	Straight	DN 10	Rp $\frac{3}{8}$ x R $\frac{3}{8}$	0.038–0.40	0.79	1	-	141 260.101	
		DN 15	Rp $\frac{1}{2}$ x R $\frac{1}{2}$			1	40	141 270.101	
		DN 20	Rp $\frac{3}{4}$ x R $\frac{3}{4}$			1	25	141 280.101	
	Axial	DN 15	Rp $\frac{1}{2}$ x R $\frac{1}{2}$	0.038–0.40	0.79	1	-	143 220.101	
	Angled-angled, right	DN 15	Rp $\frac{1}{2}$ x R $\frac{1}{2}$	0.038–0.40	0.79	1	-	145 220.101	
	Angled-angled, left	DN 15	Rp $\frac{1}{2}$ x R $\frac{1}{2}$	0.038–0.40	0.79	1	-	147 220.101	

* The flow coefficient corresponds to the water flow in m³/h through the valve at a given valve stroke (proportional offset, e.g. 1 K or 2 K) and a differential pressure of 1 bar.

**The flow coefficient Kvs is the flow coefficient of the valve at nominal stroke (100 % open).

Radiator lockshield valves type 456

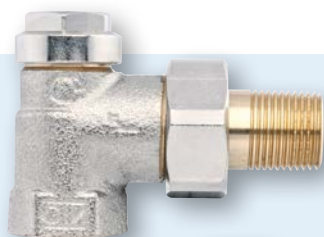

- Fully adjustable
- Shutting off individual radiators
- Reproducible adjustment



Application To shut off individual radiators so that maintenance work or painting can be performed without having to drain the entire heating system. Suitable for small, medium and large water volumes. For installation in single-pipe and dual-pipe heating systems.

Description Radiator lockshield valve type 456 with drain, shut-off and adjustment function. With cap (version M) to protect against incorrect operation. Adjustable according to flow diagram (see operating instructions). The selected setting is reproducible due to the integrated stroke limiter/stop (not version M Eco) and thus independent of draining. The optional filling and draining unit FEV with hose connection G $\frac{1}{2}$ can be used for easy and fast draining. Draining capacity equal to flow coefficient 1.1. Versions M Eco without stroke limiter.

Technical specifications

System connection

See ordering table

Adjustment range at 10 kPa

405 l/h

Nominal pressure

Max. 10 bar

Nominal diameter

DN 10, DN 15, DN 20

Operating temperature range

Medium: $T_{max} = 120 \text{ }^{\circ}\text{C}$

Housing

Gunmetal, nickel-plated

Version BG: not nickel-plated

i

Please use valve body Vario, VarioQ or Vario-DP in the flow to adjust the required water volume.

See page 272 for prices.
See page 273 for accessories.

Radiator lockshield valves type 456

Types and dimensions (mm)

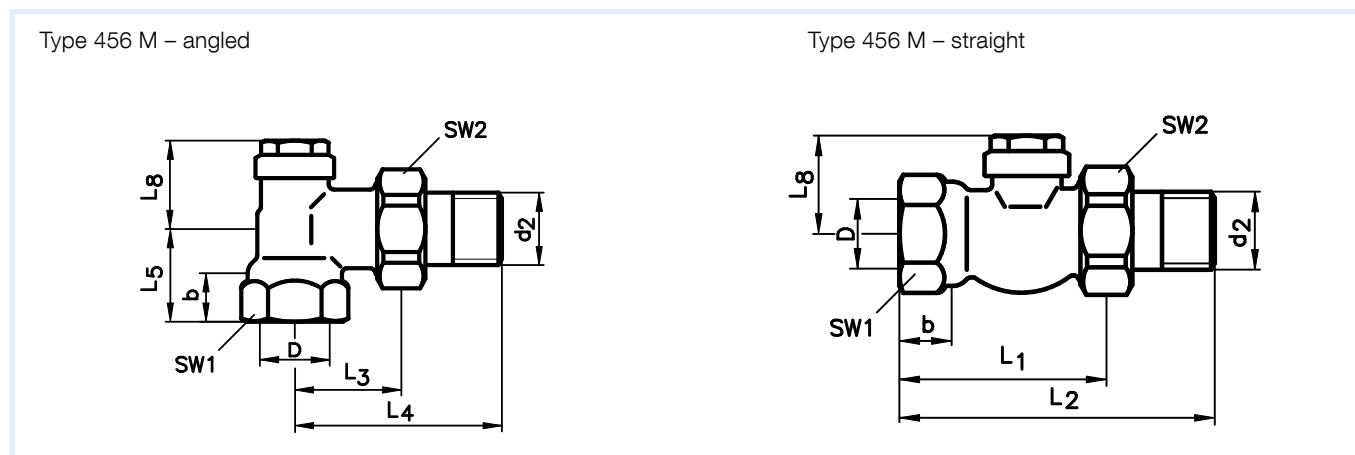

Dimensions (mm)

DN	D	d ₂	Spanner size SW 1	Spanner size SW 2	b _{min}	L ₁ ±2	L ₂ ±2	L ₃ ±1	L ₄ ±1.5	L ₅ ±1.5	L ₆	L ₇	L ₈
10	Rp ³ / ₈	R ³ / ₈	22	27	10.1	49	75	26	52	22	-	-	22
15	Rp ¹ / ₂	R ¹ / ₂	27	30	13.2	51	80	29	58	26	26.5	33.5	22
20	Rp ³ / ₄	R ³ / ₄	32	37	14.5	59	91	34	66	29	30.5	38	22

9

DG: V, PG: 2	Version	Nominal diameter	Connection	Flow coefficient Kvs* (m ³ /h)			Part no.	Price €
Type 456 M Eco for medium water volumes (without stroke limiter)								
	Angled	DN 10	Rp ³ / ₈ x R ³ / ₈	1.28	1	50	453 010	
		DN 15	Rp ¹ / ₂ x R ¹ / ₂	1.28	1	40	453 020	
		DN 20	Rp ³ / ₄ x R ³ / ₄	1.28	1	30	453 030	
	Straight	DN 10	Rp ³ / ₈ x R ³ / ₈	1.28	1	50	453 060	
		DN 15	Rp ¹ / ₂ x R ¹ / ₂	1.28	1	40	453 070	
		DN 20	Rp ³ / ₄ x R ³ / ₄	1.28	1	30	453 080	
Type 456 M for medium water volumes (standard version with stroke limiter)								
	Angled	DN 10	Rp ³ / ₈ x R ³ / ₈	1.28	1	-	453 210	
		DN 15	Rp ¹ / ₂ x R ¹ / ₂	1.28	1	-	453 220	
		DN 20	Rp ³ / ₄ x R ³ / ₄	1.28	1	-	453 230	
	Straight	DN 10	Rp ³ / ₈ x R ³ / ₈	1.28	1	-	453 260	
		DN 15	Rp ¹ / ₂ x R ¹ / ₂	1.28	1	-	453 270	
		DN 20	Rp ³ / ₄ x R ³ / ₄	1.28	1	-	453 280	

* The flow coefficient corresponds to the water flow in m³/h through the valve at a given valve stroke (proportional offset, e.g. 1 K or 2 K) and a differential pressure of 1 bar. The flow coefficient Kvs is the flow coefficient of the valve at nominal stroke (100 % open).

Thermostat combination blocks Vario THK



- Fully adjustable
- Valve insert can be replaced without system having to be drained
- Various versions and sizes for virtually any application



Application Suitable for medium water volumes. For mounting to compact or bathroom radiators with centre connection in dual-pipe heating systems. Also for installations with copper pipes.

Description Low-noise thermostat combination block with threaded connection M30 x 1.5 mm for thermostat control heads and actuators. Mounting cap with valve shut-off function. Fully adjustable with ES-SV adjustment key. Valve spindle with double O ring seal.

Technical specifications

System connection

G $\frac{3}{4}$ eurocone or G $\frac{1}{2}$ female thread

Thermostat head/actuator connection

Threaded connection M30 x 1.5 mm

Adjustment range at 10 kPa

Vario THK S: 6–95 l/h

Vario THK M: 12–215 l/h

Nominal pressure

Max. 10 bar

Nominal diameter

DN 15

Operating temperature range

Medium: T_{max} = 120 °C

Housing

Brass, nickel-plated

9

Valve pre-adjustment

Vario THK thermostat combination blocks are fully adjustable by means of the ES-SV adjustment key, starting with the open position (8 = open). The numbers 1–8 are shown on the adjustment key. Mark and counter-mark are aligned. Each $\frac{1}{8}$ of a turn corresponds to one flow characteristic, shown in a diagram (see operating instructions).

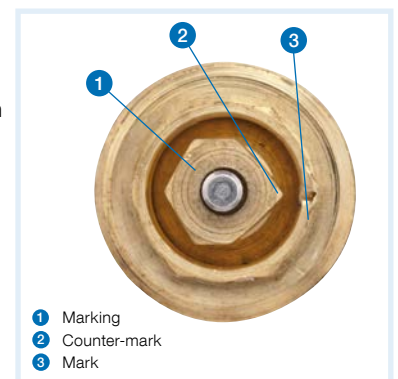

See page 273 for accessories.

Thermostat combination blocks

Vario THK

Types and dimensions (mm)



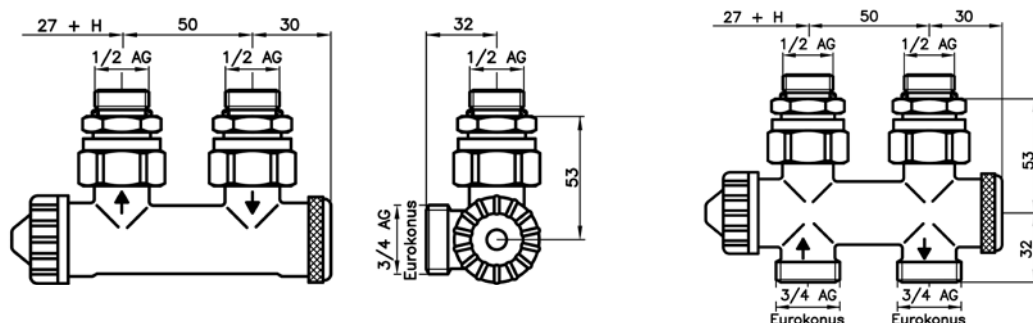

Vario THK M – version G $\frac{1}{2}$ male thread

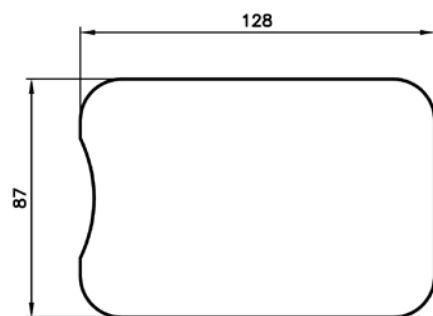

Cover Vario combination block angled/straight













9

DG: V, PG: 2	Version	Nominal diameter	Radiator connection	Flow coefficient* (m ³ /h)	Flow coefficient Kvs** (m ³ /h)			Part no.	Price €
Vario THK M for medium water volumes									
	Angled	DN 15	G $\frac{1}{2}$ female thread	0.038–0.46	0.68	1	-	221 225,101	
	Straight	DN 15	G $\frac{1}{2}$ female thread	0.038–0.46	0.68	1	-	221 275,101	

* The flow coefficient corresponds to the water flow in m³/h through the valve at a given valve stroke (proportional offset, e.g. 1 K or 2 K) and a differential pressure of 1 bar.

**The flow coefficient Kvs is the flow coefficient of the valve at nominal stroke (100 % open).

Accessories for valve bodies, lockshield valves and combination blocks

DG: V	Description	PG			Part no.	Price €
	Adjustment key ES-SV , for valve bodies Vario and VarioQ	1	1	40	140 110.850	
	Adjustment key Vario_DP	1	1	-	910 199.800	
	Adjustment key Vario Q-Kombi				422 520.800	
	Valve insert S for DN 10–DN 20	2	1	-	140 110.221	
	Valve insert M for DN 10–DN 20	2	1	-	140 210.221	
	Valve insert L for DN 10–DN 20	2	1	-	140 310.221	
	Mounting unit MGV for replacing the valve inserts Vario, VarioQ and Vario-DP	2	1	2	140 110.860	
	Filling and draining unit FEV 03 For type 454Q S and M as well as VarioQ-Kombi		1	-	422 520.810	
	Filling and draining unit FEV 04 For valve bodies Vario/VarioQ and combination blocks THK	2	1	-	140 110.870	
	Adapter for radiator R$\frac{1}{2}$ female thread Connection: $\frac{1}{2}$ " male x $\frac{3}{4}$ " male eurocone	2	1	-	273 020.040	
	Cover for thermostat combination blocks Vario THK angled or straight, DN 15	1	1	30	220 000.301	

Thermostat control heads



- With liquid probe
- Adjustable eco setting
- Adjustment range can be limited and blocked with ring
- Fits onto many other valve radiators without adapter.



Scale*	Room temperature
❄	Approx. 6 °C (automatic frost protection)
0	Zero end
1	Approx. 14 °C
2	Approx. 17 °C
3	Approx. 20 °C
4	Approx. 23 °C
5	Approx. 26 °C

* Temperature difference to next dial marks is approx. 3 K.

Application For setting and controlling the room temperature at the radiator. Version 323 suitable for valve body series Vario, VarioQ, Vario-DP, thermostat combination blocks Vario THK, VarioQ-Kombi, Twin and valve radiators with integrated valve insert with connection thread M 30 x 1.5 mm. Version 323 suitable for valve versions with Gampper clamp connection (valve bodies up to year of manufacture 1998). Version 323 KD suitable for Danfoss clamp connection (compatible series RA).

Description Thermostat control head with liquid probe, consisting of hand wheel with scale and base in different colours (see ordering table). Optional version with remote probe or remote adjustment. The desired room temperature is set with the hand wheel. The temperature probe continuously checks the room temperature, compares the measured values to the set value and controls the flow rate by opening or closing the valve to obtain the set value. Adjustment range can be limited and blocked with a ring. With optimum temperature position (eco position) adjustable via memory clip (helpful for persons with visual impairment). Frost protection position with snowflake symbol.

Tamper-proof version without zero position. Lower adjustment only to snowflake symbol. The adjustment range must be selected when the valve is mounted for the first time. A protective cap consisting of two parts which cannot be removed prevents disassembly and changes to the selected settings. The protective cap is secured by means of a screw.

Technical specifications

Connection valve body

323: Threaded connection M30 x 1.5 mm

323: Gampper clamp connection

323 KD: Danfoss clamp connection

Operating temperature range

Ambient: T_{max} 50 °C

Material

Plastic

Option

- Personalised labels

i

Special prints on the thermostat heads are possible for purchase quantities > 100 pieces.

Please note the manufacturer information concerning the connection geometry.

See page 277 for prices.

Thermostat control heads

Types and dimensions (mm)

Thermostat control head 323 with fixed probe

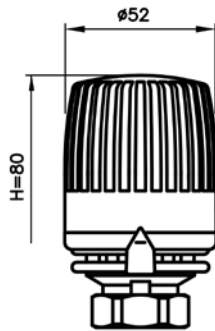

Thermostat control head 323 F with remote probe

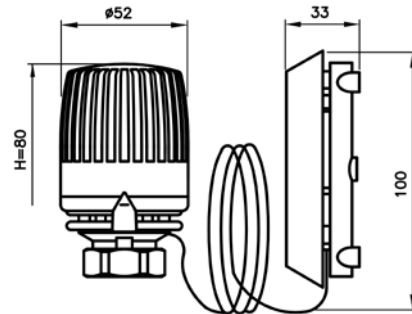

Thermostat control head 323 B with fixed probe, tamper-proof version with anti-theft system

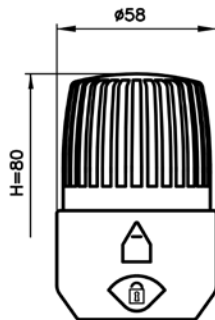

Thermostat control head 323 BF with remote probe, tamper-proof version with anti-theft system

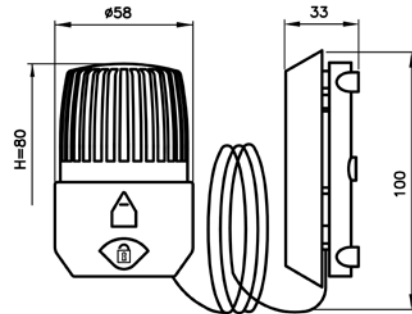

Thermostat control head 320 FV with remote adjustment and remote transmission

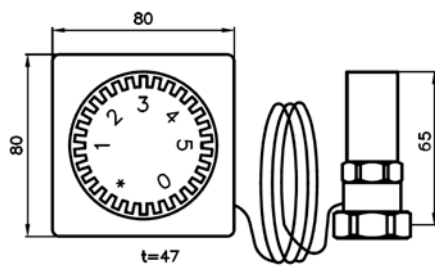

Thermostat control heads

Types and dimensions (mm)

Thermostat control head 323 KD with fixed probe, Danfoss clamp connection

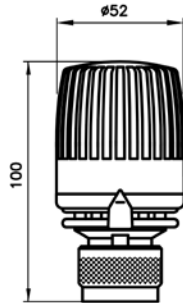

Thermostat control head 323 KD with remote probe, Danfoss clamp connection

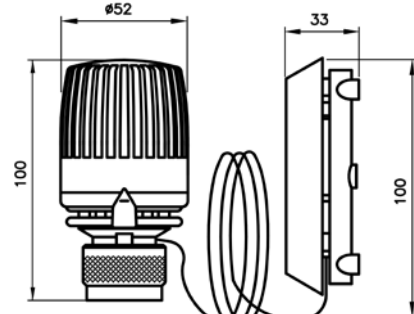



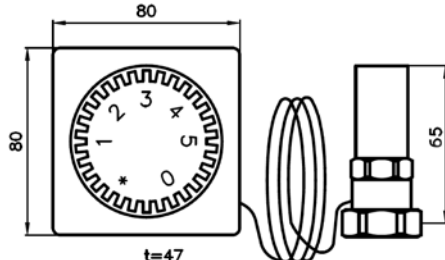



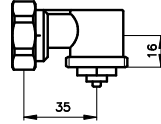

Thermostat control head 320 KD FV with remote adjustment and remote probe, Danfoss clamp connection









Angle adapter



Thermostat control heads with threaded connection





DG: V, PG: 1	Description	0 setting	Hand wheel/base	Capillary			Part no.	Price €
	Thermostat control head 323 With liquid probe, threaded connection M30 x 1.5 mm	With	White/black	-	1	50	360 002.100	
		Without	White/black	-	1	-	360 000.100	
	Thermostat control head 323 With liquid probe, threaded connection M30 x 1.5 mm	With	White	-	1	-	360 012.100	
		Without	White	-	1	-	360 010.100	
	Thermostat control head 323 With liquid probe, threaded connection M30 x 1.5 mm and personalised company label	With	White/black	-	1	200	360 002.109	On request
		Without	White/black	-	1	200	360 000.109	On request
	Thermostat control head 323 F With remote probe and bracket, threaded connection M30 x 1.5 mm	With	White/black	1.2 m	1	-	362 102.100	
		With	White/black	2 m	1	30	362 202.100	
		With	White	1.2 m	1	-	362 112.100	
		With	White	2 m	1	-	362 212.100	
		Without	White/black	1.2 m	1	-	362 100.100	
		Without	White/black	2 m	1	-	362 200.100	
		Without	White	1.2 m	1	-	362 110.100	
		Without	White	2 m	1	-	362 210.100	
	Thermostat control head 323 B Tamper-proof version, with anti-theft system, threaded connection M30 x 1.5 mm	Without	White/black	-	1	30	364 000.100	
	Thermostat control head 320 FV With remote adjustment and remote transmission, threaded connection M30 x 1.5 mm	With	White	2 m	1	12	347 200.100	

Thermostat control heads with clamp connection: GAMPPER, Danfoss

DG: V, PG: 1	Description	0 setting	Hand wheel/base	Capillary			Part no.	Price €
	Thermostat control head 323 with liquid probe, GAMPPER clamp connection. For valves from 1980–1998 (and replacement for models 313, 314, 320)	With	White/ black	-	1	50	360 002	
		Without	White/ black	-	1	50	360 000	
	Thermostat control head 323 F N with remote probe and bracket, GAMPPER clamp connection. For valves from 1980–1998 (and replacement for models 313, 314, 320) Replacement for thermostat control heads series 312 up to 1980	With	White/ black	1.2 m	1	30	362 102	
		With	White/ black	2 m	1	30	362 202	
	Thermostat control head 323 KD with liquid probe, Danfoss clamp con- nection, compatible series RA	With	White/ black	-	1	15	360 002.130	
	Thermostat control head 323 KD F with remote probe, Danfoss clamp connection, compatible series RA	With	White/ black	2 m	1	-	362 202.130	
	Thermostat control head 320 KD FV with remote adjustment and remote transmission, Danfoss clamp connec- tion, compatible series RA	With	White	2 m	1	-	347 200.130	

9

Accessories for thermostat control heads

DG: V, PG: 1	Description			Part no.	Price €
	Angle adapter M30 x 1.5 mm, white	1	-	340 010.200	
	Tamper-proof cap 323 BK for control heads 323	1	-	364 110	

Thermostat control heads 316, 312

Conversion of thermostat control heads **GAMPPER** from year of manufacture 1975 up to date

Thermostat control head 316

Description The thermostat control head 316 can be converted with the adapter 316 KH (part no. 100 010.663) so that the thermostat control heads series 323 (M30 x 1.5 mm) can be mounted to an adapter. Conversion is also possible by replacing the valve inserts. If this is done, the system must be emptied.



Thermostat control head 312

Description The thermostat control head 312 can be replaced with the thermostat control head 323 N (part no. 360 002).



Observe the following when replacing thermostat control heads series 312:

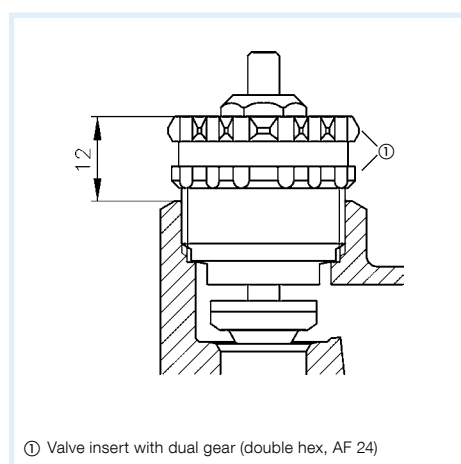

All standard series 323 thermostat control heads can be mounted to valve bodies with a dual gear.

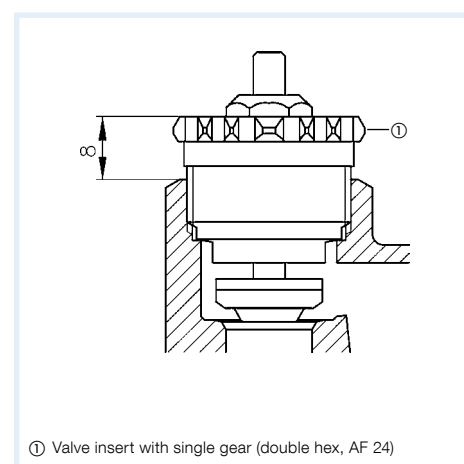

In the case of valve bodies with a single gear, thermostat control heads version "S" must be mounted. The type designation for a thermostat control head with built-in probe is 323 (N) S and for a thermostat control head with remote probe 323 F(N)S, with indication of the capillary tube length.

Thermostat control heads 313, 314, 320 S, 320 KH

Thermostat control head 313

Description The thermostat control head 313 can be replaced with the thermostat control head 323 N (part no. 360 002).



Thermostat control head 313 E

Description The thermostat control head 313 E can be replaced with the thermostat control head 323 N (part no. 360 002).



Thermostat control head 314

Description The thermostat control head 314 can be replaced with the thermostat control head 323 N (part no. 360 002).



Thermostat control head 320 S

Description The thermostat control head 320 S can be replaced with the thermostat control head 323 N (part no. 360 002).



Thermostat control head 320 KH

Description The thermostat control head 320 KH (M30 x 1.5 mm) can be replaced with the thermostat control head 323 N (part no. 360 002).



Thermostat control heads 323, adapter M30 x 1.5 mm

campper
Member of AFRISO Group

Thermostat control head 323

Description The thermostat control head 323 is available with GAMPPER clamp connection, type 323 N (part no. 360 002) or with threaded connection M30 x 1.5 mm. All series 323 (M30 x 1.5 mm) thermostat control heads can be mounted to the thermostat valves with M30 x 1.5 mm threaded connection.

The thermostat control head 320 N can be replaced with the thermostat control head 323 N (part no. 360 002).



Conversion of GAMPPER clamp connection to threaded connection M30 x 1.5 mm

For thermostat valve bodies from year of manufacture 1978

Types and dimensions (mm)

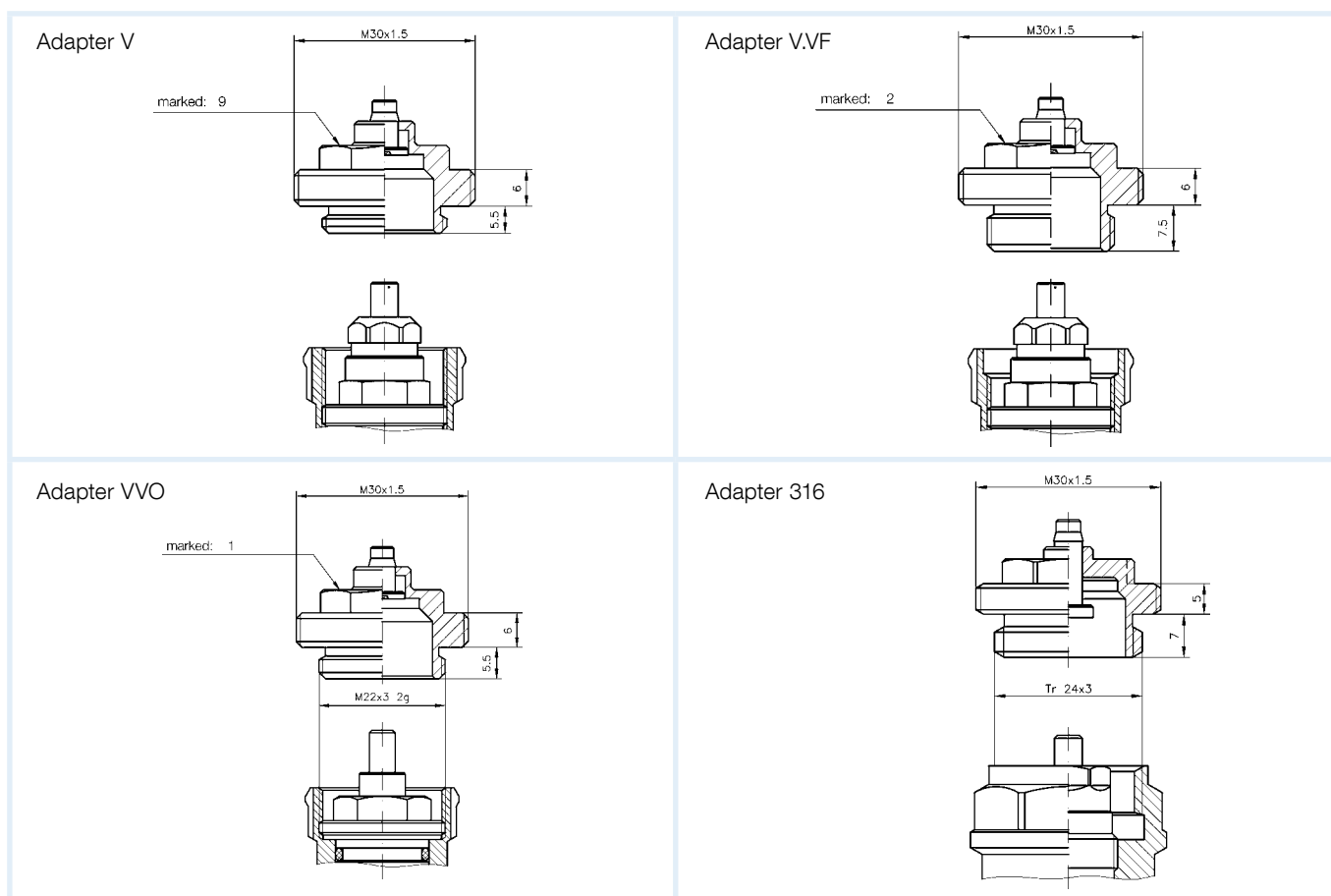

DG: V, PG: 2	Part no.	Price €
Adapter V M30 x 1.5 mm	910 049	
Adapter V.VF M30 x 1.5 mm	910 042	
Adapter VVO M30 x 1.5 mm	910 041	
Adapter 316 M30 x 1.5 mm	100 010,663	



Sacrificial anodes



Rainwater harvesting

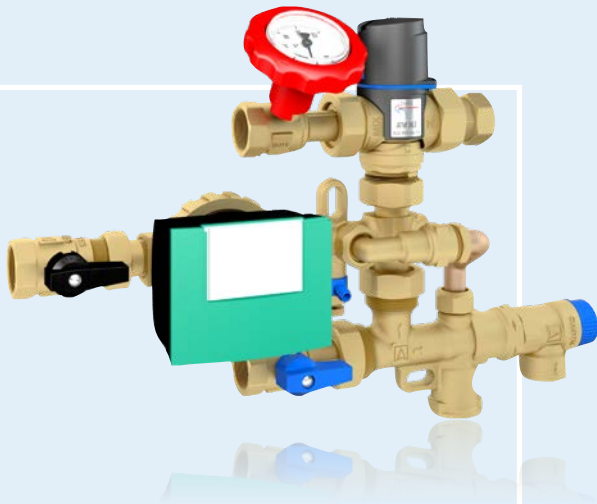

Hot water circulation systems



reddot design award
winner 2013

Domestic water system centre

CHAPTER 10

Equipment for drinking water supply, hot water treatment and rainwater harvesting

OVERVIEW

Equipment for drinking water supply, water treatment and rainwater harvesting	284
Efficient hot water treatment by intelligent circulation	288

SAFETY EQUIPMENT

Filters, check valves	285
Strainers, diaphragm safety valves MSW	286
Sacrificial anodes: Anode I, sacrificial anode and chain anode, anode tester AT1	287
Hot water circulation system WZS 100	291
Hot water circulation system WZS 75	293
Thermostatic mixing valve ATM 363 WMG	295
Thermostatic mixing valve ATM 363 WSG	296
Thermostatic mixing valves ATM	297
Circulation lance ZL 2	298
Circulation controller EC 1	299
Circulation switch ZS 2 , water safety group assembly WSG 150	300
Water safety group assembly WSG 75 and boiler safety group assemblies BFK 12	301

FILTER

Water filter WAF 04-R with pressure reducer (backwashable), automatic backwashing unit RA 01	302
------------------------------------------------------------------------------------------------------------------------------	-----

DISTRIBUTION STATIONS

Domestic water system centre HWSC	303
---------------------------------------------------	-----

RAINWATER HARVESTING

Oil tank conversion kits II + III for rainwater harvesting in gardens	306
Accessories rainwater harvesting	307
Rainwater inner lining AR-SM with magnets	308
Backup controller kit RENA	309

Equipment for drinking water supply, water treatment and rainwater harvesting

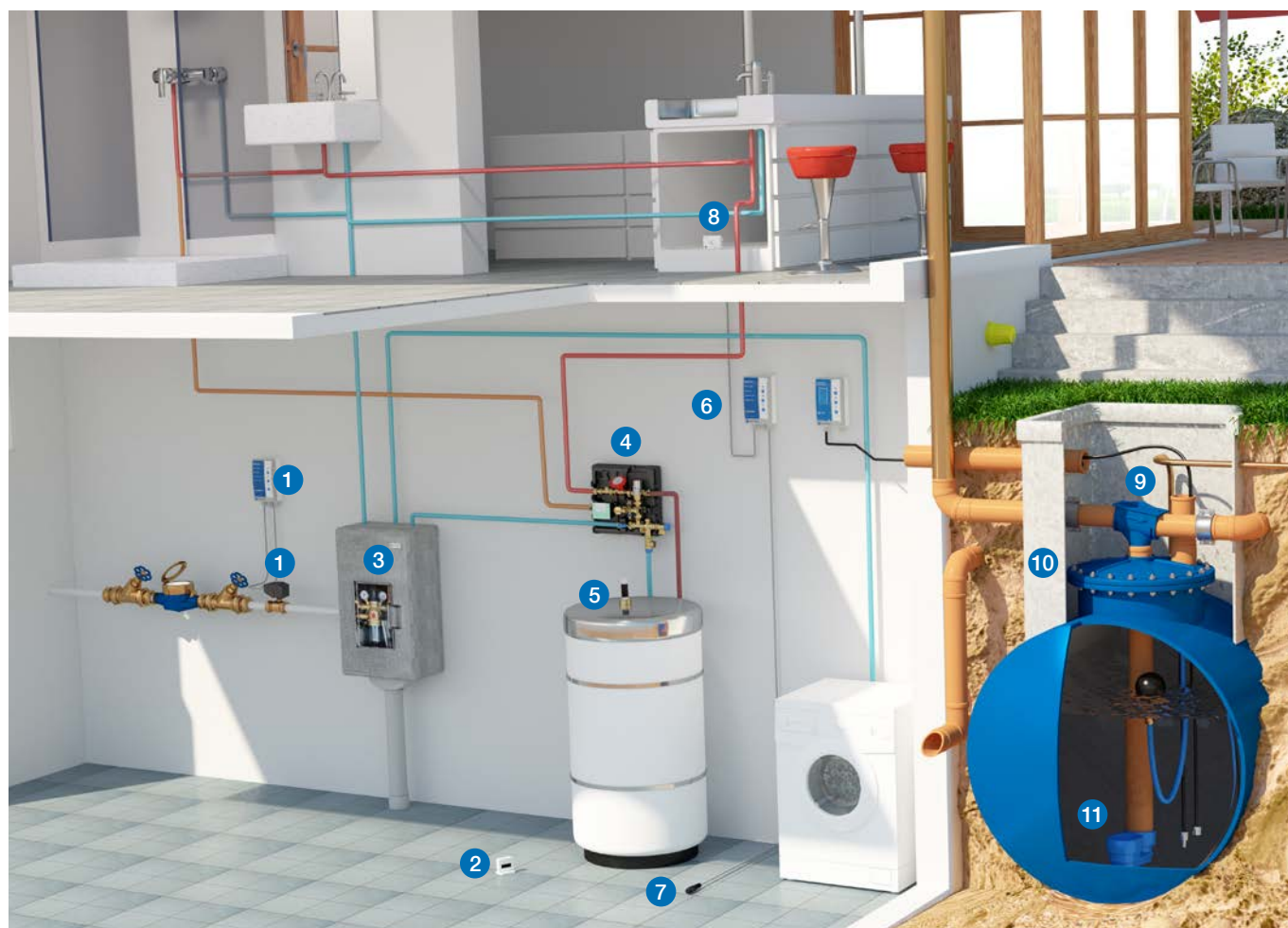

Quality water technology products

- 1 Radio-controlled water valve [WaterControl](#)
- 2 Wireless conductivity water sensor [WaterSensor con](#)
- 3 Domestic water system centre [HWSC](#)
- 4 Hot water circulation system [WZS 100](#)
- 5 Signal anode [U](#)
- 6 Oil/water alarm unit [OM 5](#)
- 7 Probe for [OM 5](#)
- 8 Battery-less wireless water sensor [WaterSensor eco](#)

Oil tank conversion kit:

- 9 Cartridge filter [PF](#) for rainwater
- 10 Plastic manhole cover
- 11 Calmed inlet

Clean water

In the area of water technology, AFRISO offers equipment for drinking water supply and products for rainwater harvesting. The focus is the protection and cleanliness of the water, the supply pipes and the installations. AFRISO products are made to the most demanding hygienic requirements and the stringent demands of the German drinking water act as well as the recommendations of the leading associations and organisations.

Filters check valves



Filter

Description Filter made of hot-pressed brass with replaceable stainless steel sieve for direct installation in domestic drinking water installations.

Technical specifications **Operating pressure**
16 bar

Mesh size
0.5 mm (500 µm)

Connections
See ordering table

Check valve



Check valve made of brass for direct installation in domestic drinking water installations. Also suitable as a gravity brake. Nylon valve, seal seat NBR, spring stainless steel.

Operating temperature range
Medium: Max. 110 °C

Operating pressure
Up to size G1: 12 bar
Size G1¼ and greater: 10 bar

Opening pressure (spring)
20 mbar

Connections
See ordering table

DG: G	Flow coefficient Kvs	PG			Part no.	Price €
Filter G³/₈	3 m ³ /h	2	1	-	42580	
Filter G¹/₂	4.5 m ³ /h	2	1	-	42581	
Filter G³/₄	7 m ³ /h	2	1	-	42582	
Filter G1	7.8 m ³ /h	2	1	-	42583	
Filter G1¼	15 m ³ /h	2	1	-	42584	
Filter G1½	21 m ³ /h	2	1	-	42585	
Filter G2	34 m ³ /h	2	1	-	42586	
Check valve G³/₈ – DN 10	2.7 m ³ /h	2	1	-	42540	
Check valve G¹/₂ – DN 15	4 m ³ /h	2	1	-	42541	
Check valve G³/₄ – DN 20	8 m ³ /h	2	1	-	42542	
Check valve G1 – DN 25	10.3 m ³ /h	2	1	-	42543	
Check valve G1¼ – DN 32	18 m ³ /h	2	1	-	42544	
Check valve G1½ – DN 40	24 m ³ /h	2	1	-	42545	
Check valve G2 – DN 50	40 m ³ /h	2	1	-	42546	

Strainers, diaphragm safety valves MSW



Strainer

Application Directly screwed into check valves or suction lines with standard pipe connections in domestic water installations.

Description Strainer, consisting of stainless steel sieve, connection piece made of nylon.

Technical specifications

Operating temperature range

Medium: Max. 110 °C

Mesh size

1.3 mm²
12 holes per cm²

Connections

See ordering table



Diaphragm safety valve MSW

For sealed drinking water heaters as per EN 806, DIN 1988 and DIN 4753-1 and for protection against overpressure.

The response pressure is factory-set.

Opening pressure/response pressure

See ordering table

Connection



See ordering table

Material

Housing: Brass (CW617N), cap: PA 6, blue

Operating temperature range

Medium: 4/110 °C

DG: G	Maximum heating capacity	PG			Part no.	Price €
Strainer G³/₈ – DN 10	-	1	1	-	20811	
Strainer G¹/₂ – DN 15	-	1	1	-	20812	
Strainer G³/₄ – DN 20	-	1	1	-	20813	
Strainer G1 – DN 25	-	1	1	-	20814	
Strainer G1¹/₄ – DN 32	-	1	1	-	20815	
Strainer G1¹/₂ – DN 40	-	1	1	-	20816	
Strainer G2 – DN 50	-	1	1	-	20817	
MSW G¹/₂ x G³/₄, 6 bar	75 kW	2	1	84	42421	
MSW G¹/₂ x G³/₄, 8 bar	75 kW	2	1	84	42422	
MSW G¹/₂ x G³/₄, 10 bar	75 kW	2	1	84	42423	
MSW G³/₄ x G³/₄, 6 bar	100 kW	2	1	84	42456	
MSW G³/₄ x G1, 6 bar	150 kW	2	1	84	42425	
MSW G³/₄ x G1, 8 bar	150 kW	2	1	84	42426	
MSW G³/₄ x G1, 10 bar	150 kW	2	1	84	42427	
MSW Rp1 x Rp1¹/₄, 6 bar	250 kW	2	1	10	42442	
MSW Rp1 x Rp1¹/₄, 8 bar	250 kW	2	1	10	42443	
MSW Rp1 x Rp1¹/₄, 10 bar	250 kW	2	1	10	42444	

Sacrificial anodes

For increased hygiene:
Anode individually packed in poly bag.



Application Protection against frequently unnoticed corrosion damage in water heaters. Primarily for use in enamelled boilers or hot water tanks with other types of passive protective coatings. Defective areas in enamel or other passive protective coatings are subject to corrosion; this causes a flow of current which is transformed into a protective current by the anode material. The anode material thus falls victim to electro-chemical corrosion. Since the protective function of the anode rod is not unlimited, consumed anodes have to be replaced.

Anode I

Description Sacrificial anode Ø 22, 26, 33 mm as per EN 12828, made of magnesium alloy, for isolated installation. With M8 male, threaded connection, isolating piece and earth cable. Consumption check with AT1 anode tester.

Sacrificial anode

Sacrificial anode Ø 22, 26 or 33 mm as per EN 12828, made of magnesium alloy, suitable for all standard tanks. With screw fitting G $\frac{3}{4}$, G1 or G1 $\frac{1}{4}$, without signal. See the ordering table for various versions with different lengths, threads and diameters.

Chain anode

Flexible sacrificial anode Ø 22 mm as per EN 12828, made of magnesium alloy. A flexible anode is used if there is insufficient space to install a rigid anode. Consisting of five individual elements along a stainless steel rope and a screw fitting G $\frac{3}{4}$ or M8 threaded connection piece (see also Anode I) Length approx. 800–900 mm.



Anode tester AT1

Tester for consumption check of anode I or isolated standard sacrificial anodes.

- Handheld tester with 4-level LED indication
- Fast and easy indication of the condition of the anode
- Reliability of the water heater due to preventive maintenance – consumed anodes are replaced in good time

DG: G	PG			Part no.	Price €
Anode I 22–500-M8	3	1	45	69806	
Anode I 26–500-M8	3	1	35	69811	
Anode I 33–500-M8	3	1	20	69808	
Sacrificial anode 22–500-$\frac{3}{4}$	3	1	40	69815	
Sacrificial anode 22–700-$\frac{3}{4}$	3	1	30	69817	
Sacrificial anode 26–500-1	3	1	30	69819	
Sacrificial anode 26–700-1	3	1	20	69821	
Sacrificial anode 33–550-1$\frac{1}{4}$	3	1	15	69825	
Chain anode 22–800-$\frac{3}{4}$ (5 elements)	3	1	35	69829	
Chain anode I 22–900-M8 (5 elements)	3	1	35	69804	
Accessories (DG: H)					
Anode tester AT1 for anode I	4	1	-	69842	

Hot water circulation system WZS 100

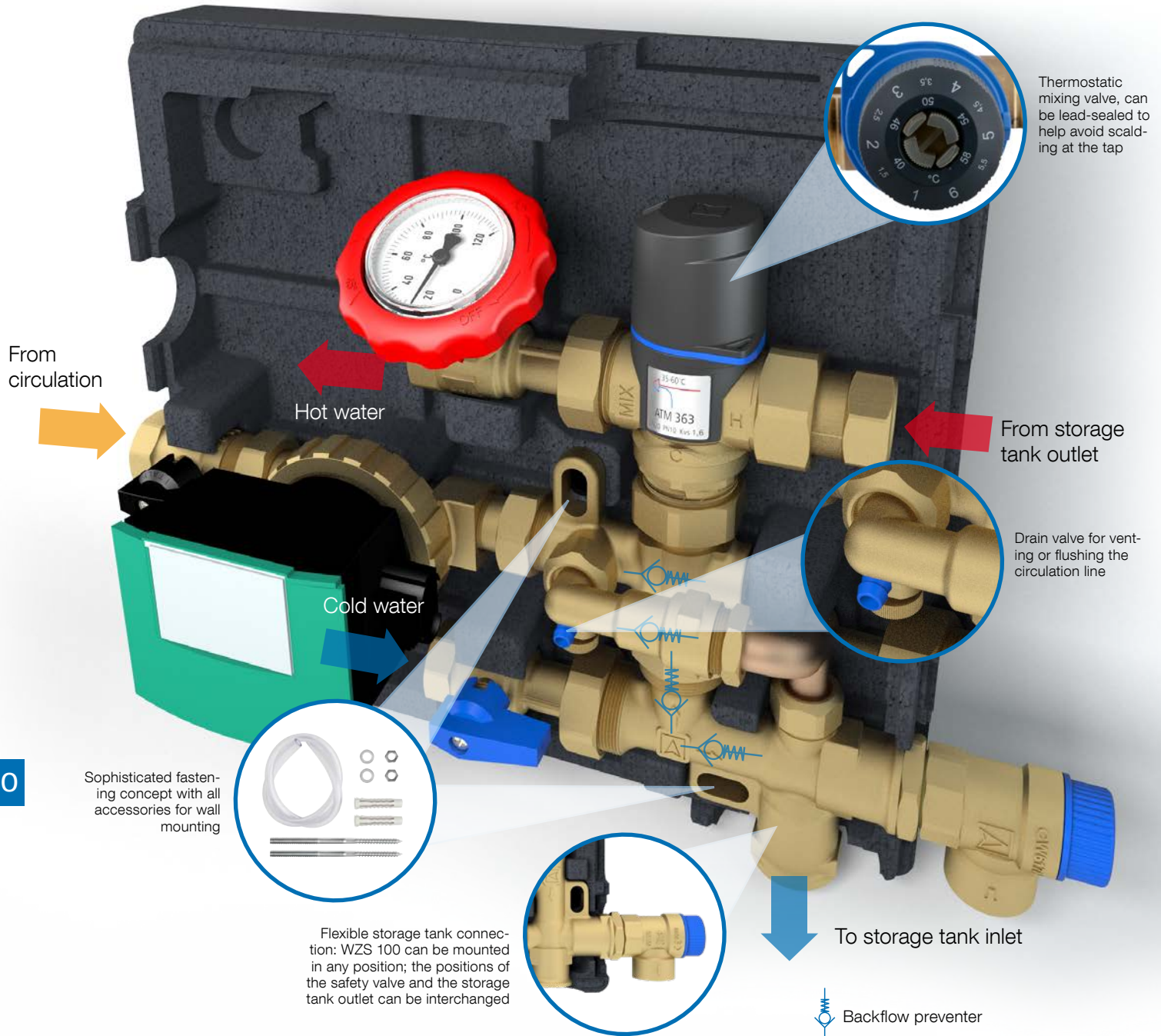

Assembly for easy connection to solar, hot water, hygienic or combination storage tanks (with or without circulation connection at the storage tank)

- + Pre-assembled, tightness-tested and heat-insulated assembly speeds up installation/commissioning and facilitates logistics
- + Fully secured: diaphragm safety valve, backflow preventer and all shut-off valves integrated
- + Intelligent circulation distribution by means of integrated bypass: No back circulation, no "mixing" of thermal layers in the stratified storage tank
- + Integrated pump for plug & play operation
- + Thermometer for easy on-site checks (range 0/120 °C)

Unwanted, inefficient incorrect installations of stratified storage tanks

As a result of the increasing use of renewable energy in domestic technology applications, the number of hygienic stratified storage tanks with a temporary operating temperature of more than 60 °C is also on the rise. In order to connect such tanks in a more efficient way, to keep the thermal layers and to limit the outlet temperature of the hot water, the installation of the service water line involves several fittings and connection parts.

Optimum design of the circulation can often be a major challenge in terms of hydraulics and logistics. For example, the service water connections to the water heater have been made according to the old, inefficient logic or important parts have been "forgotten".

In most cases, the circulation line of stratified storage tanks is connected to the cold water inlet of the hot water tank. This way, the hot circulation water of the return flows through the lower area of the stratified storage tank which is usually cooler. In the lower area, the returning circulation water is cooled - only to be heated up again in the upper thermal layers.

The consequence: The storage medium is evenly heated – which destroys the important thermal layering. The high energy density in the upper thermal layers is lost. In the most adverse case, the function of a solar system is prevented or extremely limited in the transition period.

Typical implementation issues:

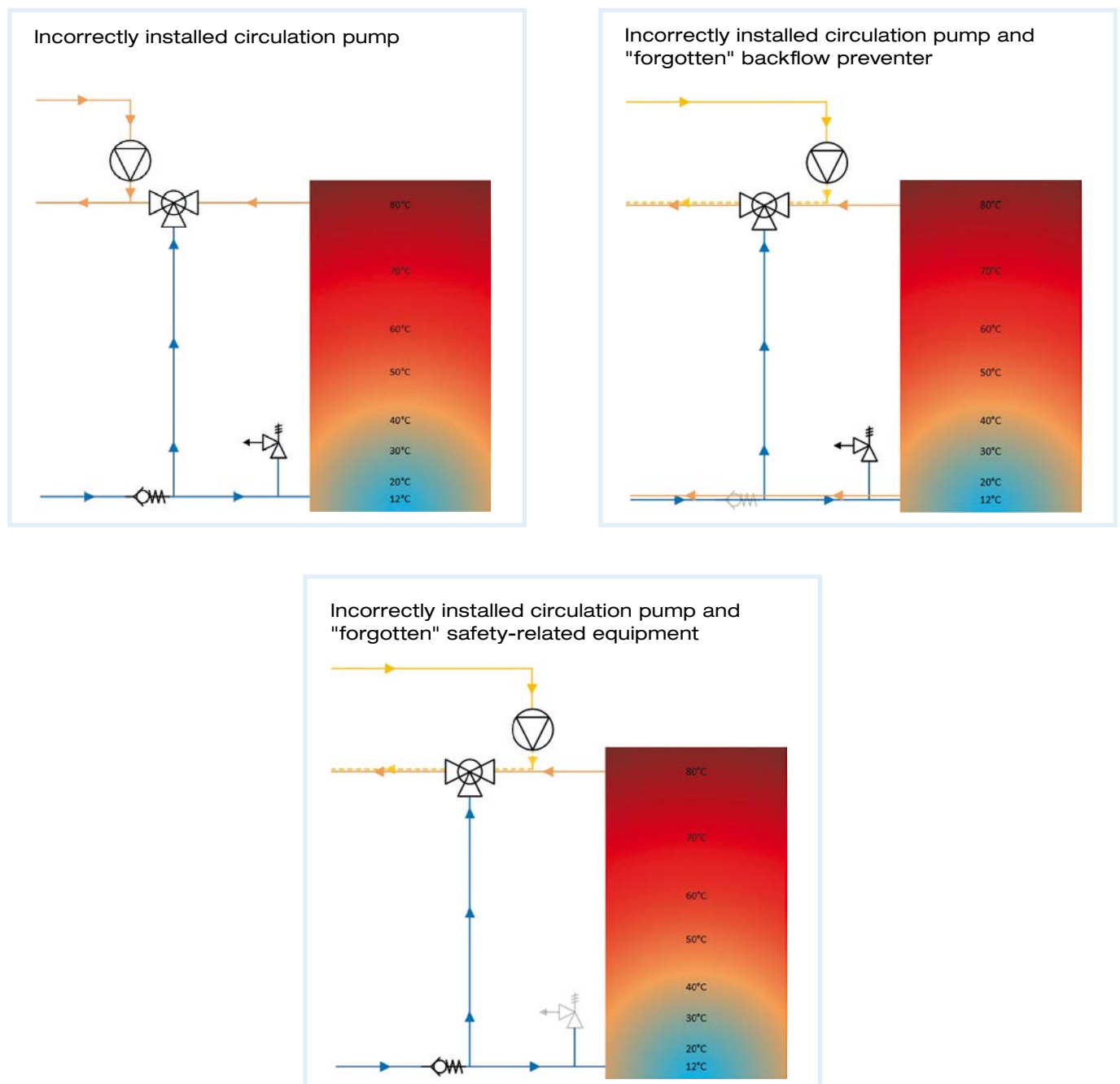

WZS 100 ensures reliable function and efficient operation

With the use of WZS 100, the return part of the circulation line has a direct connection to the cold water inlet of the thermostatic mixing valve. Depending on the water temperatures at the inlets of the mixing valve, they will open or close the hot water inlet and the cold water inlet to a higher or less high degree. A partial volume of the returning circulation water flows directly to the cold water connection of the mixing valve. Depending on the mounting situation (internal/external circulation), the other partial volume can be resupplied upstream of the tank. This allows for considerable energy savings.

WZS 100 thus allows for intelligent circulation distribution without back-circulation and without "mixing" of the temperatures in the stratified storage tank. With minimum installation effort, all possibilities of advanced stratified storage systems for efficient heating of water can be used to their full potential.

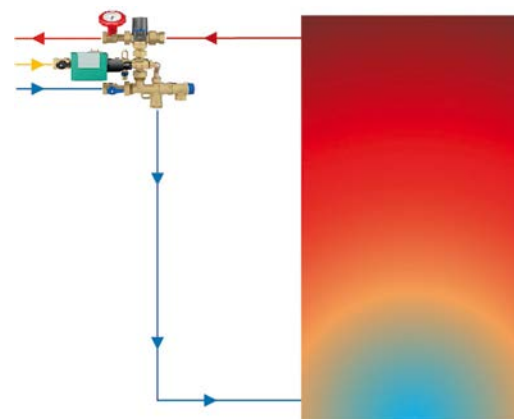

Function example 1 (internal circulation via bypass)

Cold water flows via the safety fitting of WZS 100 to the cold water end via line A to the mixing valve and via line B to the water heater. In the example, the temperature adjustment knob of the thermostatic mixing valve ATM 363 is set to a hot water temperature of 60 °C. The unmixed hot water temperature at the storage outlet is 80 °C due to the high buffer temperature as a result of solar or regenerative energy. The mixing valve now opens or closes the path to the hot and cold water end depending on the temperature. Due to the fast control characteristics of ATM 363, the adjusted temperature is reached at the valve outlet (mix). Only the amount of heating energy really required to ensure the desired water temperature is actually used. If the hot water has reached the last consumer or the point of re-entry (service water to circulation), it is pumped back to the circulation unit via the newly developed flow distributor. Depending on the temperature, it distributes the water via line A to the mixing valve or via line B to the water tank. What's best: Even though there are two flow lines, the pump has to overcome only one check valve. The circulation pump has to overcome less counterforce which results in enormous energy savings and a prolonged service life of the pump.

Function example 2 (operation with circulation lance)

Same system requirements as in function example 1, but with use of circulation lance ZL 2. In this configuration, the water can only flow the direct path via the circulation lance (as opposed to the bypass version). This results in doubled benefits: Increased comfort as well as energy and heating cost savings.

This is achieved by supplying the returning hot water of the circulation directly to the upper thermal layer of the water heater so that it does not have to flow through the complete tank. At the same time, there is always enough hot water available to supply the fittings without inconvenient delays.

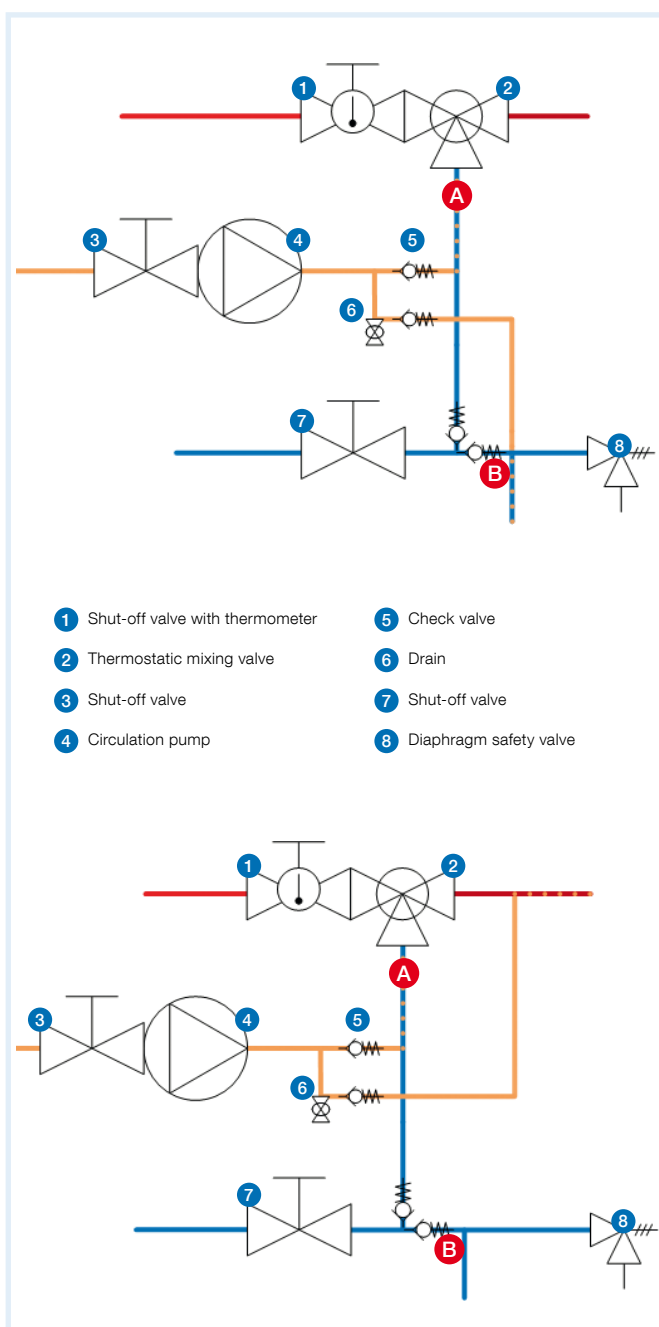

Hot water circulation system WZS 100

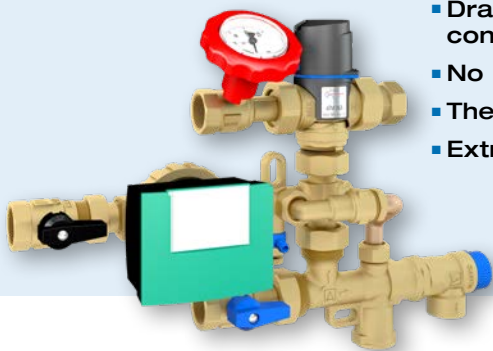

- Dramatic energy savings in circulation mode compared to conventional circulation systems
- No mixing of the temperatures in the stratified storage tank
- Thermally controlled hot water temperature (with scald protection)
- Extremely low mounting effort and fast commissioning



Application Circulation system for professional implementation of a service water circulation connection to an energy storage tank (hot water tank/stratified storage tank) which is operated at temperatures higher than 60 °C either permanently or temporarily. Also suitable for stratified hygienic storage and bivalent service water tanks. If used with older existing systems (for example, hot water tanks with wood, solar, gas, heat pump or oil-fired boiler), controlled circulation to meet actual demands results in high energy savings. The hot water circulation system is optimally suited for use with renewable energies in domestic technology applications, primarily in single and two family homes.

Description Compact, pre-assembled and tightness-tested hot water circulation system in form-fit heat insulation part, consisting of thermostatic mixing valve with integrated scald protection, circulation pump with all necessary functional components such as shut-off valves, variable safety group assembly, backflow preventer and connection parts as per DIN 1988.

The hydraulic separation of the flow paths ensures correct operation of the circulation pump since it has to overcome only one backflow preventer in any operating condition and thus avoids mixing of the cold water inlet in the circulation path.

Technical specifications

System connections

G $\frac{3}{4}$ female

Connection lance / bypass

G $\frac{1}{2}$ female

Operating temperature range

Medium: Max. 95 °C

Mixing temperature

35/60 °C

System pressure

Max. 10 bar

Flow coefficient Kvs

1.6 m³/h

Safety valve

Opening pressure: 6 bar

Insulation

Polypropylene EPP

Dimensions

W x H x D: 320 x 300 x 146 mm

Technical specification circulation pump Wilo-Star-Z NOVA

Degree of protection

IP 42

Supply voltage

AC 230 V, 50 Hz

Power input

2–4.5 W

DG: G, PG: 2	Part no.	Price €
Hot water circulation system WZS 100	68405	

Hot water circulation system WZS 100

Dimensions (mm)

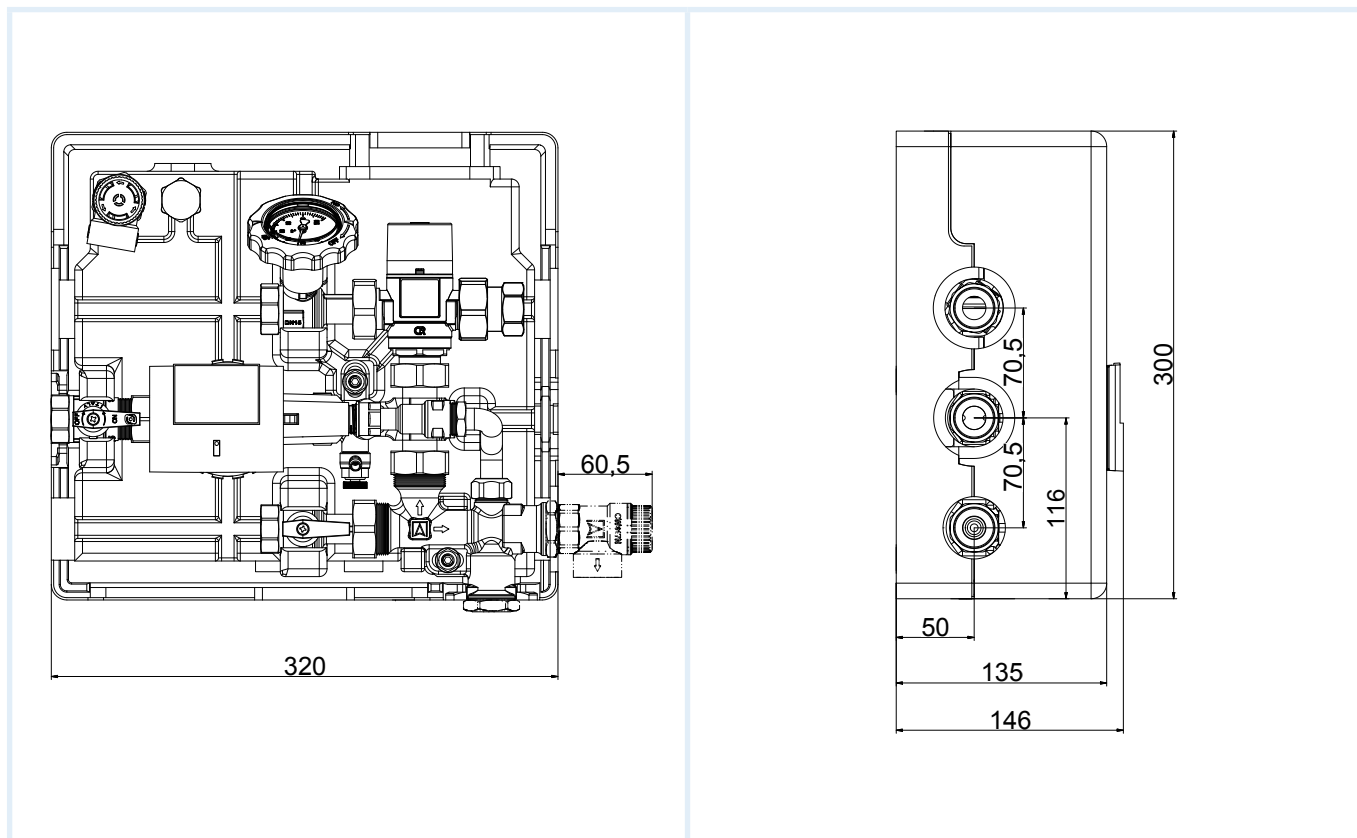

Hot water circulation system WZS 75



- Compact hydraulic assembly for storage tanks with existing safety-related equipment
- Easy connection of a circulation line with existing safety-related equipment
- Thermally controlled hot water temperature (with scald protection)
- Considerable time savings during mounting

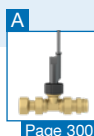

Application Circulation system for professional implementation of a service water circulation connection to an energy storage tank with existing safety-related equipment (hot water tank/stratified storage tank) which is operated at temperatures higher than 60 °C either permanently or temporarily. WZS 75 is ideal for retrofitting existing systems, primarily in single-family and two-family homes.

Description Compact, pre-assembled and tightness-tested hot water circulation system, consisting of thermostatic mixing valve with integrated scald protection, thermometer, shut-off valve, drain valve for venting or flushing the circulation line as well as connection parts as per DIN 1988. The hydraulic assembly is suitable for storage systems which are already fitted with safety-related equipment such as diaphragm safety valves or backflow preventers or where such equipment is to be installed in the form of conventional individual components. Storage systems without safety-related equipment can be retrofitted with the safety group assembly WSG 150.

WZS 75 optimises temperature control in the hot water circulation and ensures that the temperature in the storage system is not unnecessarily reduced. A partial volume of the returning circulation water flows directly to the cold water inlet of the thermostatic mixing valve via an internal connection and is added there.

Technical specifications

System connections

G $\frac{3}{4}$ female thread, G1 female thread

Operating temperature range

Medium: Max. 95 °C

Mixing temperature

35/60 °C

System pressure

Max. 10 bar

Flow coefficient Kvs

1.6 m³/h

Technical specification circulation pump Wilo-Star-Z NOVA

Degree of protection

IP 42

Supply voltage

AC 230 V, 50 Hz

Power input

2–4.5 W

Scope of delivery

Assembly without insulation

DG: G, PG: 2	Part no.	Price €
Hot water circulation system WZS 75	68416	

Hot water circulation system WZS 75

Dimensions (mm)

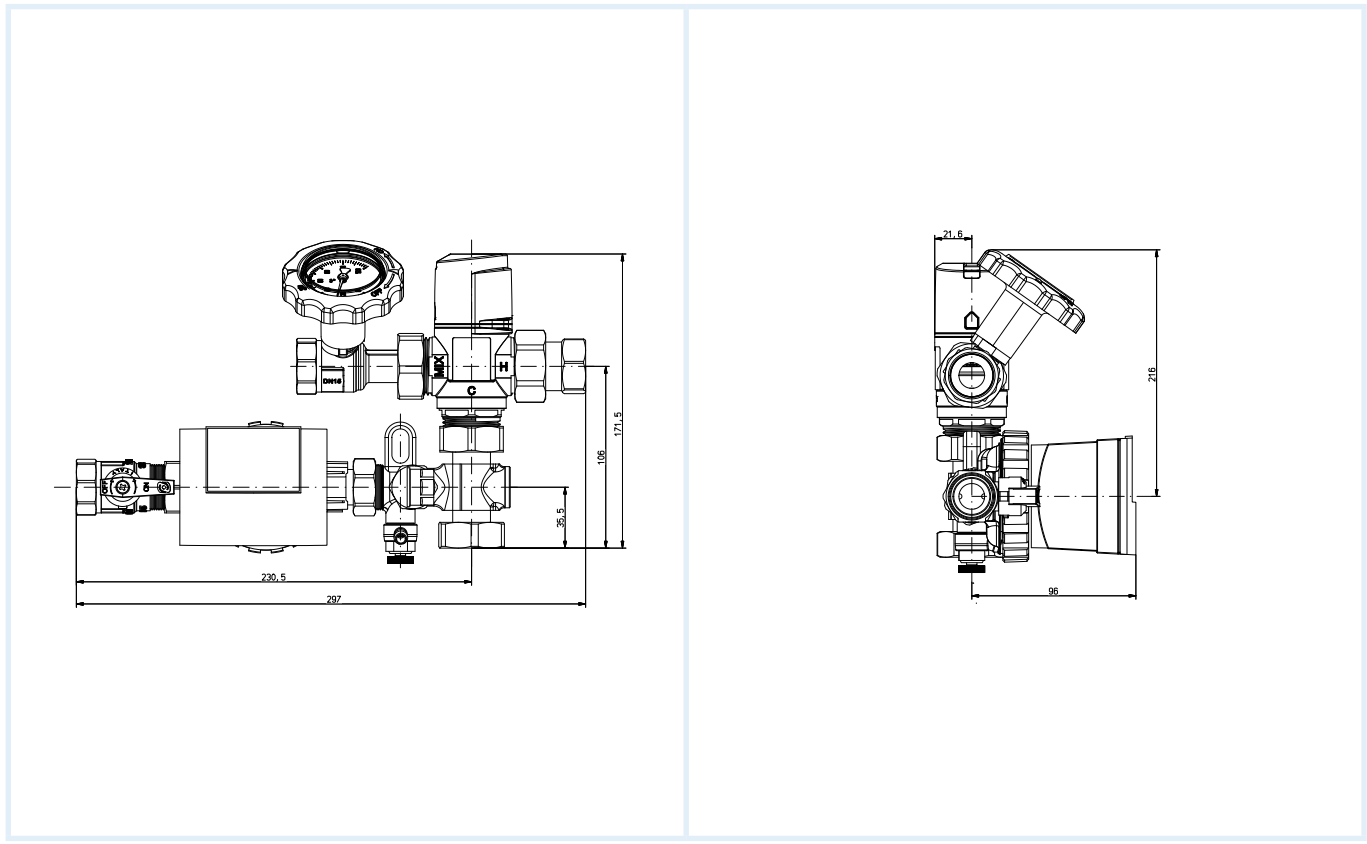

Thermostatic mixing valve

ATM 363 WMG



- Compact assembly for storage tanks with existing safety group assembly and pump
- Thermally controlled hot water temperature (with scald protection)
- Easy mounting without time-consuming, extensive insulation work
- Circulation lance can be connected

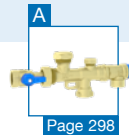
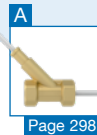

Application Mixing valve for control of hot water in drinking water systems, boilers or drinking water heaters as per EN 806. Suitable for implementing or retrofitting a service water circulation connection to an energy storage tank (hot water tank/stratified storage tank) with existing safety-related equipment and pump.

Description Compact, pre-assembled and tightness-tested assembly in form-fit insulation. ATM 363 WMG consists of an adjustable thermostat mixing valve, connection pieces as per DIN 1988 and a flow distribution unit with backflow preventer, lance connection and drain valve for venting or flushing the circulation line. Mixing valve with control knob with temperature scale (35/60 °C) for easy adjustment of the temperature of the water to be mixed. A cap protects the control knob against improper operation; it can be lead-sealed to help prevent unwanted adjustments. The selected adjustment is visible through the window in the cap. If the cold water line is interrupted, the mixing valve automatically closes the hot water supply to help protect against scalding.

Technical specifications

System connections

G $\frac{3}{4}$ female thread, G1 female thread

Connection lance / bypass

G $\frac{1}{2}$ female

Operating temperature range

Medium: Max. 95 °C

Mixing temperature

35/60 °C

System pressure

Max. 10 bar

Flow coefficient Kvs

1.6 m³/h

Insulation

Polypropylene EPP

10

Dimensions (mm)

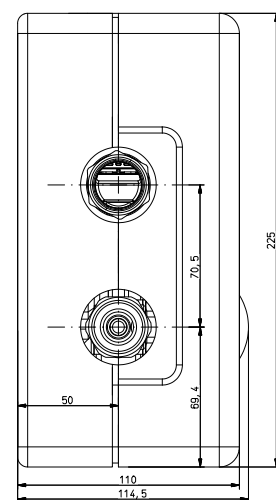
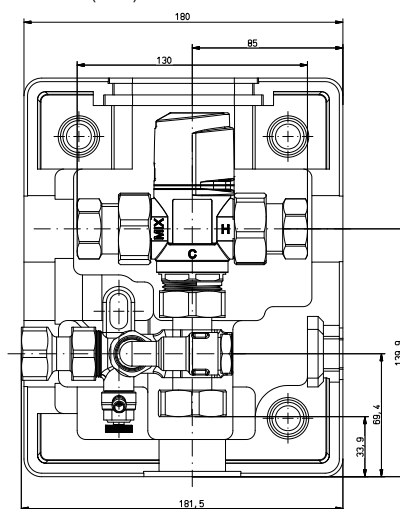

DG: G, PG: 2	Part no.	Price €
Thermostatic mixing valve ATM 363 WMG	68417	

Thermostatic mixing valve ATM 363 WSG

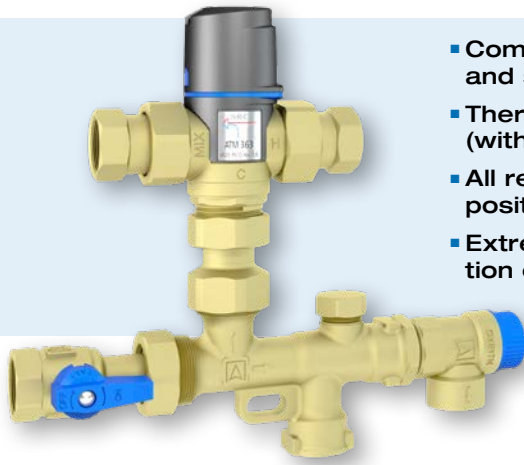

- Compact assembly for tankless water heaters and solar-heated drinking water heaters
- Thermally controlled hot water temperature (with scald protection)
- All relevant backflow preventers at the correct positions
- Extremely time-saving as compared to installation consisting of many individual parts

Application Mixing valve with boiler safety group assembly for controlling hot water at solar-heated drinking water heaters and hot water storage tanks with hot water heating according to flow principle, as well as drinking water storage units. Ideal for applications in which circulation is not necessary or if the water heater already has a circulation connection.

Description Compact, pre-assembled and tightness-tested assembly consisting of adjustable thermostatic mixing valve, safety group assembly with integrated backflow preventers, shut-off valve and safety valve. Mixing valve with control knob with temperature scale (35/60 °C) for easy adjustment of the temperature of the water to be mixed. A cap protects the control knob against improper operation; it can be lead-sealed to help prevent unwanted adjustments. The selected adjustment is visible through the window in the cap. If the cold water line is interrupted, the mixing valve automatically closes the hot water supply to help protect against scalding.

Technical specifications

System connections

G $\frac{3}{4}$ female

Operating temperature range

Medium: Max. 95 °C

Mixing temperature

35/60 °C

System pressure

Max. 10 bar

Flow coefficient Kvs

1.6 m³/h

Safety valve

Opening pressure: 6 bar

Scope of delivery

Assembly without insulation

Dimensions (mm)

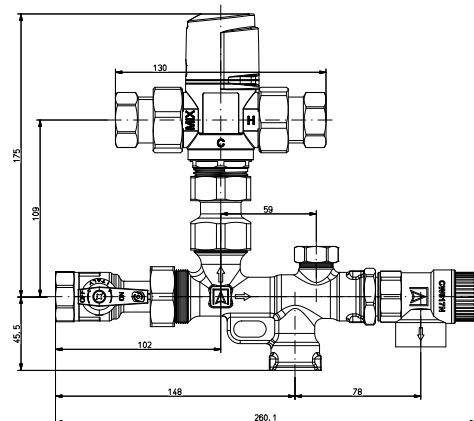

DG: G, PG: 2	Part no.	Price €
Thermostatic mixing valve ATM 363 WSG	68419	

Thermostatic mixing valves

ATM



- High accuracy, fast response
- With integrated scald protection
- Maintenance-free
- Ideal for showers and smaller underfloor heating circuits
- Cap with window and scale, can be lead-sealed (ideal for public facilities)



Control knob with temperature scale

Application Universal units for controlling hot water in sanitary applications, solar-heated, tankless water heaters or for smaller underfloor heating circuits which are directly connected to the flow (max. 60 °C). Also for panel heating systems such as wall or underfloor heating systems which require a constant mixed water temperature to avoid damage to floors and pipes. Suitable for drinking water or water with up to 50 % glycol.

Description Thermostatic mixing valve as per EN 1111 with base made of brass and cap and control knob made of high-strength plastic. With temperature scale (20/43 °C or 35/60 °C) for easy adjustment of the temperature of the water to be mixed. A cap protects the control knob against improper operation; it can be lead-sealed to help prevent unwanted adjustments. The selected adjustment is visible through the window in the cap. If the cold water line is interrupted, the mixing valve automatically closes the hot water supply to help protect against scalding. The new chamber geometry also helps to avoid damage caused by overpressure during closing (backflow preventer at cold water end). The internal geometry as well as the materials used at the control surfaces help to ensure that control errors (for example, caused by lime deposits on the sealing surfaces) are practically excluded. ATM is maintenance-free.

Technical specifications

Operating temperature range

Medium: Max. 90 °C
(short-term 110 °C)

Nominal pressure

Max. 10 bar
Dynamic operating pressure: Max. 5 bar

Flow rate

Flow coefficient 1.6 m³/h or 2.5 m³/h

Accuracy

±2 °C (EN 1111)

Material

Housing: Brass (CW626N),
dezincification-resistant
Upper part: Plastic (ABS)
Control knob: Plastic (ABS)
Seals: EPDM

Dimensions (mm)

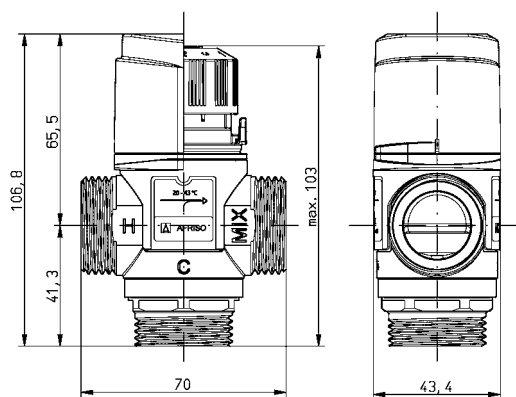

10

DG: G, PG: 2	DN	Kvs	Connection	Temperature	Part no.	Price €
ATM 341	15	1.6 m ³ /h	G¾ male thread	20 / 43 °C	78247	
ATM 343	15	1.6 m ³ /h	G¾ male thread	35 / 60 °C	78246	
ATM 331	20	1.6 m ³ /h	Rp¾ female thread	20 / 43 °C	78249	
ATM 333	20	1.6 m ³ /h	Rp¾ female thread	35 / 60 °C	78248	
ATM 361	20	1.6 m ³ /h	G1 male thread	20 / 43 °C	78245	
ATM 363	20	1.6 m ³ /h	G1 male thread	35 / 60 °C	78244	
ATM 561	20	2.5 m ³ /h	G1 male thread	20 / 43 °C	78283	
ATM 563	20	2.5 m ³ /h	G1 male thread	35 / 60 °C	78284	
Screw connection kit			G¾ female x G¾ male	-	12 201 10	
Screw connection kit			G1 female x G1 male	-	12 202 10	

Circulation lance ZL 2

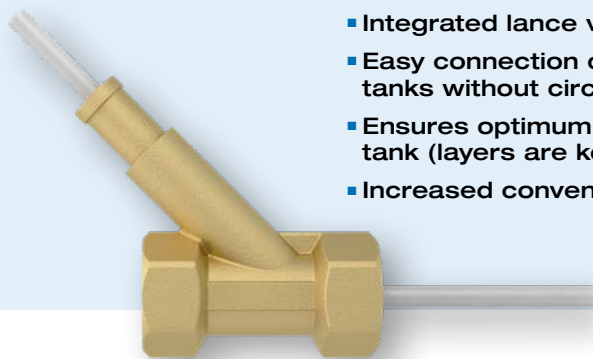

- **Integrated lance valve, design with no dead space**
- **Easy connection of stratified combination storage tanks without circulation connection**
- **Ensures optimum function of the stratified storage tank (layers are kept)**
- **Increased convenience due to shorter lead time**

Application Hydraulic connection assembly for tanks with drinking water flow heating to allow circulation mode for the domestic drinking water supply. Can be used in conjunction with the hot water circulation system WZS 100.

A stratified combination storage tank (corrugated pipe tank) which heats up drinking water according to the flow principle usually does not have a circulation connection. This frequently results in a connection problem. With the circulation lance, the circulation connection is made via the hot water outlet end. Thus, correct function of the stratified storage tank is ensured; the thermal layers are kept. The results in heating cost savings and electrical energy savings.

Description Circulation lance for mounting in hygienic tank, consisting of part SPP with sleeve \varnothing 8 mm and PE-Xc pipe \varnothing 8 mm. A part of the circulation return volume is resupplied to the tank via the lateral circulation connection of ZL 2, heated up by means of the counter flow method and removed via the hot water connection of ZL 2. This is done via the circulation hose located in the heat exchanger pipe of the tank. Returning the circulating hot water in an optimum way ensures that the layers in the stratified storage tank remain intact.

Technical specifications

System connections
Rp1 female

Connection circulation return
G $\frac{3}{4}$ male

Operating temperature range
Medium: Max. 110 °C

System pressure
Max. 6 bar

Material
Brass

Circulation hose
 \varnothing 8 mm meshed polyethylene, 1.5 m long

Approval
Lance valve: SVGW certificate no. 0809-5419

Function principle external circulation

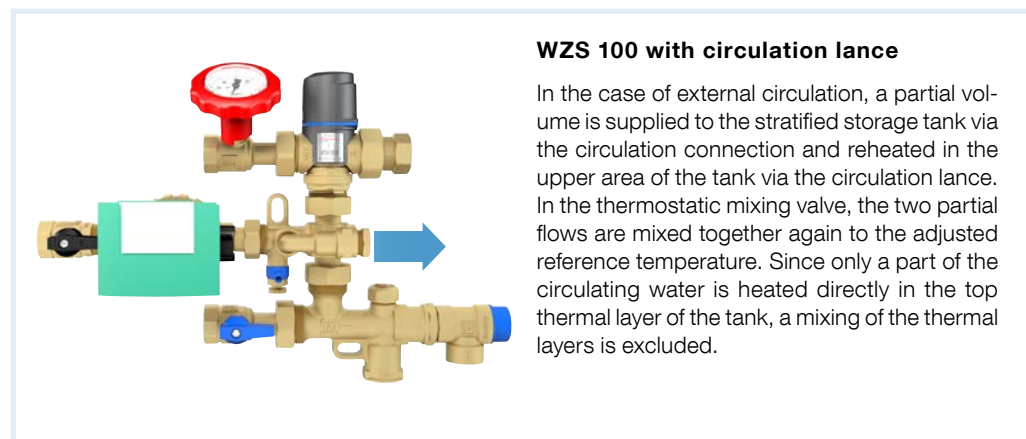

WZS 100 with circulation lance

In the case of external circulation, a partial volume is supplied to the stratified storage tank via the circulation connection and reheated in the upper area of the tank via the circulation lance. In the thermostatic mixing valve, the two partial flows are mixed together again to the adjusted reference temperature. Since only a part of the circulating water is heated directly in the top thermal layer of the tank, a mixing of the thermal layers is excluded.

DG: G, PG: 2	Part no.	Price €
Circulation lance ZL 2	68406	

Circulation controller EC 1



- Demand-controlled pump control for hot water circulation
- Legionellae protection function
- High energy savings due to intelligent pump control
- Intuitive use, reliable operation

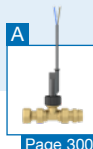

Application For demand-controlled optimum control of the hot water circulation in conjunction with the hot water circulation system WZS 100. Unnecessary periods of operation (time control or thermal control) and energy costs can be reduced.

Description Circulation controller in wall mounting housing with controller adjustment via menus. A flow switch connected to EC 1 (for example, circulation switch ZS 2) monitors water withdrawal at the hot water end. After short opening of a tap in the hot water line, the circulation pump is switched on and stopped after an additional running time adjusted by the user has elapsed. This turns any standard fitting in the hot water system into a kind of "remote control".

This is energy savings in two ways: due to the demand-controlled pump, the storage tank is not cooled down unnecessarily by circulating the hot water, and the shorter running time of the circulation pump saves energy.

Technical specifications

Functions

- Circulation control
- Time control
- Additional pump running time

Operating temperature range

Ambient: 0/40 °C

Display

LC display, multifunctional combination display
Menu control with 3 pushbuttons

Supply voltage

AC 220–240 V

Inputs

1 x sensor input for circulation switch

Switching output

1 semiconductor relay

Housing

Wall mounting housing made of plastic (PC, ABS, PMMA)
Control panel mounting possible
W x H x D: 172 x 110 x 49 mm
Degree of protection IP 20 (EN 60529)
Protection class II

Scope of delivery

- Circulation controller
- Mounting material

10

i

For full functionality of the circulation controller, the circulation switch ZS 2 is required.

DG: G, PG: 2	Part no.	Price €
Circulation controller EC 1	68407	

Accessories WZS series

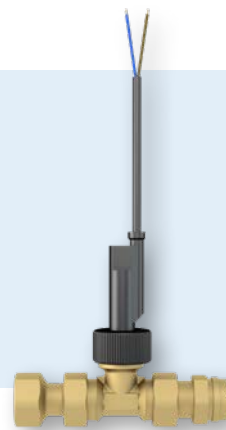

Circulation switch ZS 2

Application Can be used in conjunction with the circulation controller EC 1 for demand-controlled circulation control via opening and closing of a tap.

Description Circulation switch in pipe piece for direct mounting in the insulation of the hot water circulation system WZS 100.

Mandatory for optimum operation of the circulation controller EC 1.

Technical specifications

Brass pipe piece
G $\frac{3}{4}$ female, DN 20, PN 10

Operating temperature range
Medium: Max. 100 °C

Switching point
1.5 ± 0.7 l/min in horizontal mounting position
1.8 ± 0.75 l/min in other mounting position

Switching contact
Closes if value is exceeded

Output
Voltage-free contact

Sheathed cable
Length: 1.5 m PVC



Water safety group assembly WSG 150

Safety group assembly for sealed hot drinking water systems, boilers or drinking water heaters as per EN 806 to secure the inlet of the energy storage tank (hot water tank/stratified storage tank) and for protection against overpressure and back-circulation.

Compact, tightness-tested storage tank connection kit with integrated backflow preventers, shut-off valve and safety valve. Easy adaptation to on-site requirements by rotating the safety valve. WSG 150 is very easy to mount, even directly to a water heater. WSG 150 can be extended at the 1" connection (remove cap).

System connections
G $\frac{3}{4}$ female

Operating temperature range
Medium: Max. 95 °C

System pressure
Max. 10 bar

Safety valve
Opening pressure: 6 bar
G $\frac{3}{4}$ x G $\frac{3}{4}$

Flow coefficient Kvs
4.97 m³/h

Dimensions (mm)

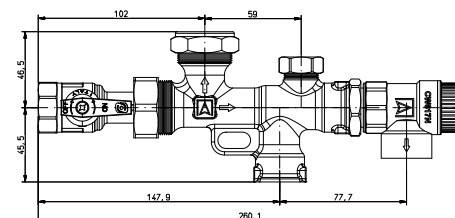

DG: G, PG: 2	Part no.	Price €
Circulation switch ZS 2	68408	
Water safety group assembly WSG 150	68412	

Boiler safety group assemblies



Water safety group assembly WSG 75/10 and WSG 75/8

Application For sealed hot drinking water systems or drinking water heaters as per EN 806, DIN 1988 and DIN 4753-1 and for protection against overpressure.

Description Combination fitting with rotatable safety valve 8 bar or 10 bar, Bourdon tube pressure gauge 0/16 bar, shut-off fitting, check valve and test screw. Noise characteristics as per DIN 4109 class 1.

Technical specifications

Connections
Soldered screw connection Ø 18 mm at both ends

Safety valve
8 bar or 10 bar, rotatable
G $\frac{1}{2}$ x G $\frac{3}{4}$
Max. heating capacity: 75 kW

Flow coefficient Kvs
2.8 m³/h

Operating pressure
8 bar or 10 bar

Dimensions
W x H: 95 x 95 mm

Housing
Brass

Bourdon tube pressure gauges
0/16 bar, Ø 50 mm, connection G $\frac{1}{4}$

Options
Other connection types



Boiler safety group assembly BFK 12

For sealed hot drinking water systems or drinking water heaters as per EN 806, DIN 1988 and DIN 4753-1 and for protection against overpressure.

Combination fitting with safety valve 6 bar or 10 bar, shut-off fitting, check valve and test screw. Noise characteristics as per DIN 4109 class 1.

Connections
Compression fitting at both ends Ø 15 mm

Safety valve
6 bar or 10 bar

Flow coefficient Kvs
2.2 m³/h

Operating pressure
10 bar

Dimensions
W x H: 90 x 98 mm

Housing
Brass

10

DG: G, PG: 2	Safety valve			Part no.	Price €
Boiler safety group assembly BFK 12/6	6 bar	1	-	77986	
Boiler safety group assembly BFK 12/10	10 bar	1	-	77988	
Water safety group assembly WSG 75/8	8 bar	1	-	77978	
Water safety group assembly WSG 75/10	10 bar	1	-	77976	

Water filter WAF 04 R with pressure reducer, backwashable



- With integrated pressure reducer
- Inlet pressure compensation for constant outlet pressure
- Rotatable cover to indicate the next backwashing date
- Transparent filter cup shows degree of pollution of the filter
- Innovative backwashing system – fast and thorough cleaning of the filter, low water consumption



Application For the protection of drinking water installations against corrosion as per DIN 1988. The pressure reducer reduces the inlet pressure to an even, system-specific pressure in order to protect the installation and to ensure economical water consumption. Water filters help to keep pollutants such as rust particles and sand grains from reaching the domestic water installation and thus protect valves, machines, flow heaters, etc. from malfunctions caused by pollution. Ideal for modernisation of domestic water installations where an existing filter needs to be replaced.

Description DVGW-tested water filter, compact plastic version with backwashable fine filter, integrated pressure reducer and pressure gauge for the outlet pressure. The fine filter insert consists of an upper part and a combined lower part. In the operating state "Filtration", the small upper filter is closed so that the water can only flow through the main filter from the outside to the inside. When the ball valve for "Backwashing" is opened, the filter is pressed down until the water supply to the outside of the main filter is interrupted. At the same time, the water flow through the upper filter is opened. The water required for cleaning the filter flows through the upper sieve, the rotating impeller and the main filter from the inside to the outside. This ensures effective cleaning of the filter across the entire surface of the sieve at full inlet pressure. When the ball valve is closed again, the filter automatically resumes normal operation.

The pressure reducer operates on the basis of a force comparison system, i.e. the force of a spring counteracts the force of a diaphragm. The inlet pressure neither acts in the opening nor in the closing direction. Therefore, pressure changes at the inlet pressure side do not affect the outlet pressure.

Technical specifications

Medium
Drinking water

Inlet pressure
Max. 16 bar

Outlet pressure
1.5–6 bar

Operating temperature range
Medium: Max. 30 °C

Mounting position
Vertical or horizontal with filter cup down

Connection
G $\frac{3}{4}$, G1, G1 $\frac{1}{4}$ as required

Material
Housing: High-grade plastic
Fine filter: Stainless steel, mesh size 110 μ m
Filter cup: Shock-resistant, transparent plastic

DVGW approval
NW-9311AT2316



Automatic backwashing unit RA 01 (accessory) for setting the backwashing intervals.

DG: G	PG	Part no.	Price €
WAF 04 R – G $\frac{3}{4}$	1	42714	
WAF 04 R – G1	1	42715	
WAF 04 R – G1 $\frac{1}{4}$	1	42716	
Accessories			
Automatic backwashing unit RA 01	4	42739	

Domestic water system centre HWSC



reddot design award
winner 2013

Heat-insulated assembly with transparent door for easy monitoring and backwashing (mark via memory pointer)

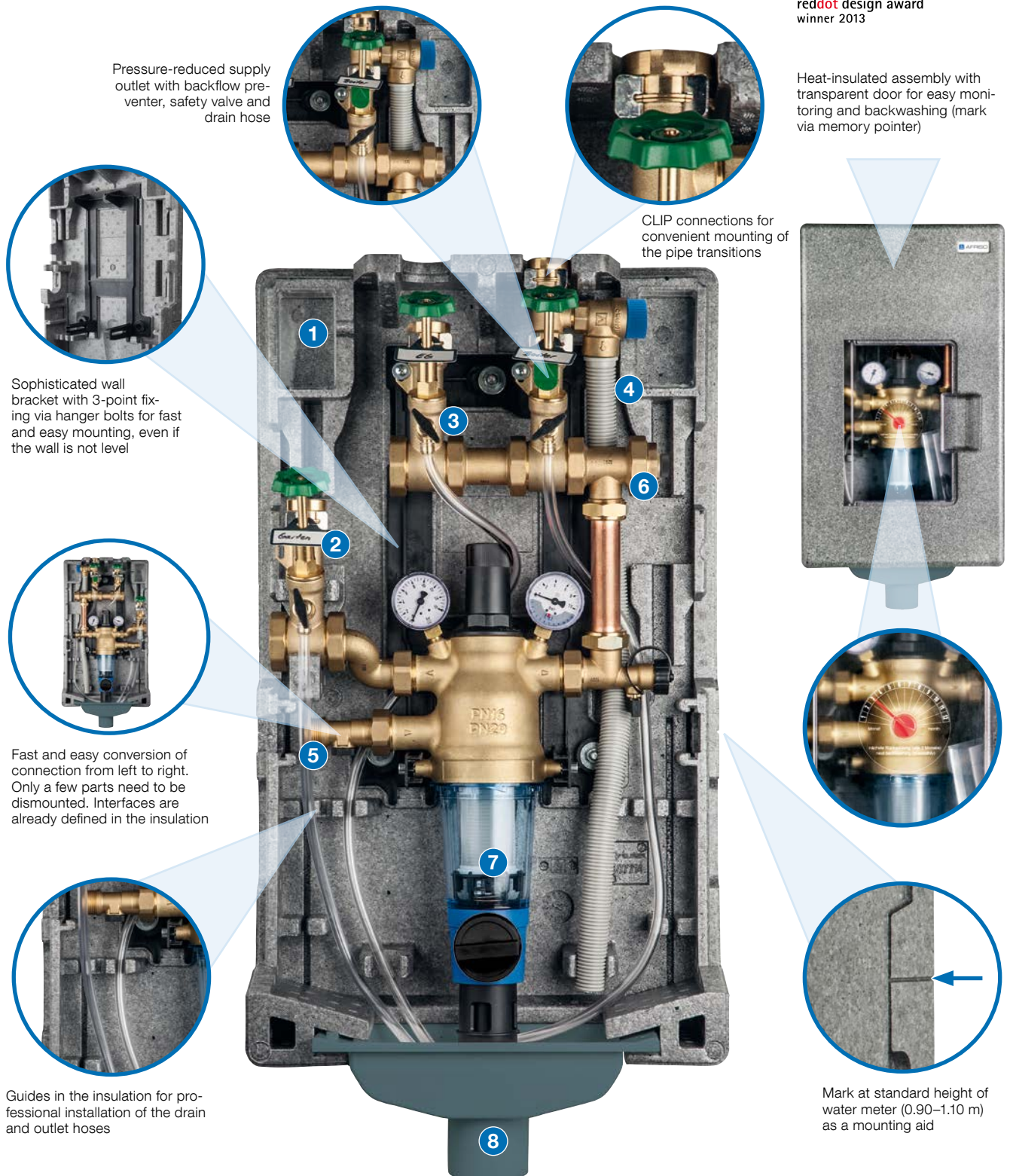

- | | |
|----------------------------------------------------------------------------------------------|-------------------------------------------------------------------------------------|
| 1 Storage compartment for spare seals/silicone grease | 5 Backflow preventer, DVGW approval |
| 2 Filtered high pressure outlet (as per DIN 1988), e.g. for garden line | 6 Connection G $\frac{1}{4}$ for sampling valve |
| 3 Pressure-reduced supply outlets with drain hoses (1 outlet with backflow preventer) | 7 Filter combination with fine filter and pressure reducer, DVGW approval |
| 4 Safety valve (6 bar) outlet hose | 8 Drain unit consisting of funnel (DN 75) and reducing adapter (DN 75/DN 50) |

Domestic water system centre HWSC



- **Extremely compact system centre**
395 x 760 mm (W x H)
- **Lightning-fast, easy installation**
- **Innovative backwashing system – fast and thorough cleaning of the filter element, low water consumption**
- **Modular design: Can be extended by additional pressure-reduced outlets, automatic backwashing unit, refill combinations, etc.**



Automatic backwashing unit RA 01 (accessory) for setting the time intervals.



reddot design award
winner 2013

Application For drinking water installations as per EN 806, DIN 1988 and DIN 4753-1. The system centre combines all functions of conventional water distribution installations in a small-footprint unit: the pressure reducer reduces the inlet pressure to an even, system-specific pressure in order to protect the installation and to ensure economical water consumption. The water filter keeps pollutants such as rust particles or sand grains from reaching the domestic water installation, thus protecting valves, machines, boilers, etc. from malfunctions caused by dirt. With its straightforward design and unobtrusive colour, the domestic water system centre fits in perfectly with modern equipment rooms, basements and utility rooms.

Description Compact, tightness-tested domestic water system centre as a complete solution for the distribution of drinking water in buildings. The base version of HWSC consists of a backflow preventer, filter combination with fine filter and pressure reducer, drain unit with connection possibility to the wastewater system, three supply outlets, safety valve and all function components. The individual components are DVGW-certified or comply with the DVGW regulations. The assembly is contained in a form-fit insulation for easy access and operation. The integrated transparent front door allows for checking the system pressure and the safety valves and provides easy access to start backwashing; it is not necessary to remove the upper part of the insulation. The memory pointer on the door lets you set the date for the next backwashing procedure.

HWSC excels with a dramatic reduction of the installation time: a drilling template is shipped with the unit for precise positioning of the three holes. Hanger bolts allow for precise adjustment of the domestic water system centre to the wall and enable easy horizontal and vertical alignment. HWSC features a variable height adjustment from 65 to 115 mm to allow for precise adaptation to the individual distance of the water meter from the wall. The default connection setting is intended for left-side connection, but HWSC can be converted to right-side connection in a matter of minutes.

The integrated filter combination features an innovative backwashing system with rotating impeller which ensures fast and thorough cleaning of the fine filter and low water consumption. The entire sieve surface of the filter insert is cleaned at high pressure. The pressure reducer reduces the inlet pressure to an even, system-specific pressure; part of the water flows directly and without pressure reduction to the high-pressure outlet for the garden line. If this is not required, it can be converted into an additional pressure-reduced supply outlet. The insulation can accommodate up to four supply outlets; any additional outlets must be mounted outside the insulation. Due to the modular design and the defined connections, it is easy to fit extensions with an automatic backwashing unit, a refill combination for filling heating systems and the connection of a sampling valve or a water softening system.



Door for fast checking the system pressure as well as the safety valve or for starting backwashing.

Domestic water system centre HWSC

Technical specifications

Medium

Drinking water

Inlet pressure

Max. 16 bar

Flow coefficient Kvs

4.2 m³/h

Operating temperature range

Medium: 5/30 °C

Mounting position

Vertical

Supply outlets to the top

Dimensions (housing)

W x H x D: 395 x 665 x 210 mm

Weight

Approx. 12 kg

Connection drinking water

Inlet: R1

Supply system: G $\frac{3}{4}$ female thread

Connection waste water

DN 50, DN 75

Material

Fittings: Brass (CW617N)

Insulation: Polypropylene EPP

Filter housing: Brass (dezincification-resistant)

Fine filter: Non-corroding steel

Seals: EPDM

DVGW approval

All components are DVGW-conform.

Components with DVGW approval: filter combination, backflow preventer, seals



SVGW approval

Components with SVGW approval:

Filter combination

Certificate no. 1310-6204

Dimensions (mm)

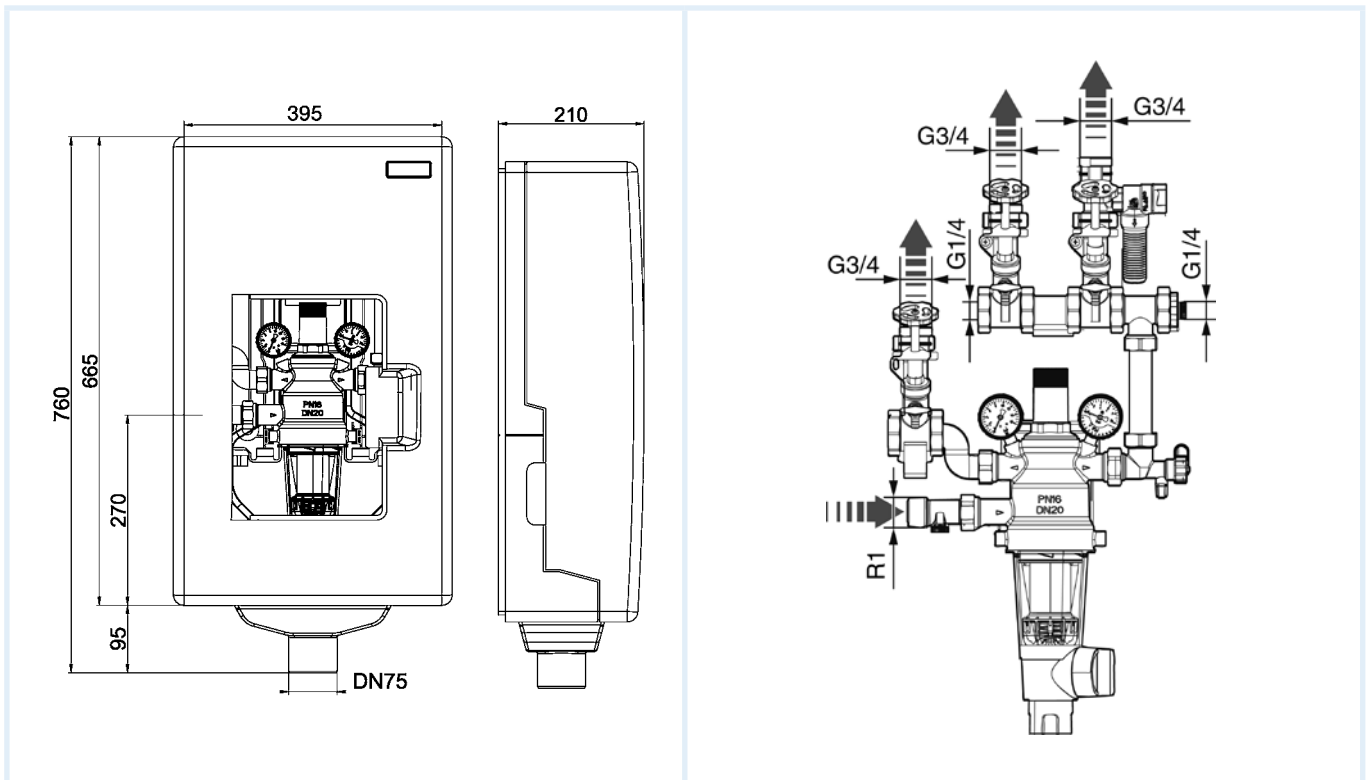

10

DG: M	PG	Part no.	Price €
Domestic water system centre HWSC	2	42755	
Connection kit for refilling of heating system	2	42757	
Connection kit for water softening	2	42756	
Extension supply outlet G $\frac{3}{4}$ female thread	2	42758	
Automatic backwashing unit RA 01	4	42739	

Oil tank conversion kits II + III for rainwater usage in gardens

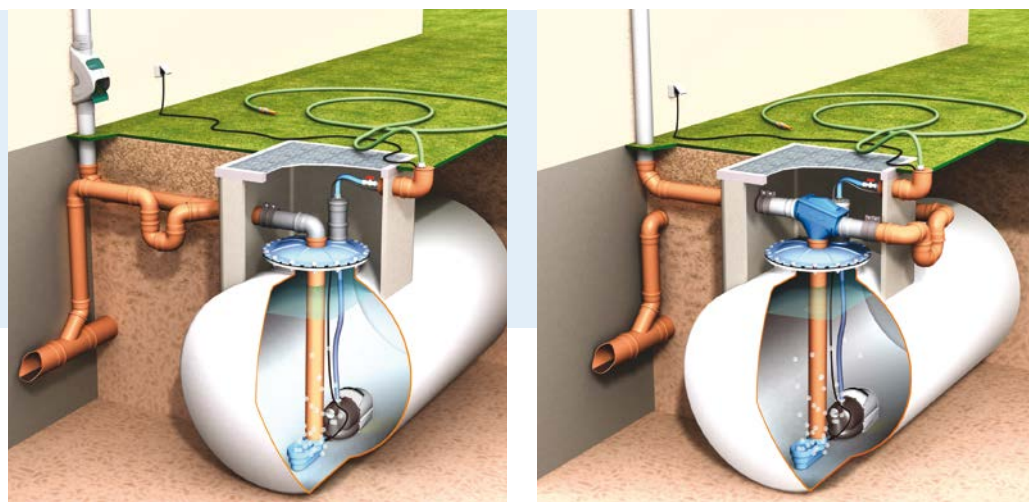

Application Oil tank conversion made easy. We supply a number of special rainwater components for quick and easy installation of rainwater harvesting systems. The tank cover is the most important component of the kit as it enables simple and clean piping through two openings. The pipe is routed from the downpipe to the tank top and connected to the filter system. Depending on the site conditions and the available space in the manhole, it is recommended to install a downpipe filter or a cartridge filter. Pipe couplers are used to connect the filter elements. The pipe to the sewage system must form a siphon using the drain pipe elbows. A self-priming jet pump with integrated pressure and dry run protection is ideally suited for water withdrawal.

Scope of delivery **Oil tank conversion kit II for rainwater usage in gardens (up to 75 m² roof area):**

- Plastic manhole cover Ø 500 mm



- Rainus downpipe filter with 2 quick-action connection pieces (DN 100)



- Calmed inlet



Oil tank conversion kit III for rainwater usage in gardens (up to 210 m² roof area):

- Plastic manhole cover Ø 500 mm



- Cartridge filter PF with 2 quick-action connection pieces (DN 100)

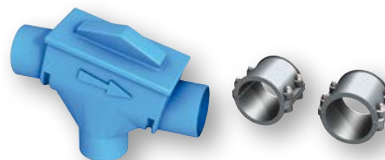

- Calmed inlet







10

i See page 308 for inner linings for rainwater.
See pages 7, 8, 12, 100 for level measurement.

DG: M, PG: 1			Part no.	Price €
Oil tank conversion kit II	1	-	53076	
Oil tank conversion kit III	1	-	53077	

Accessories rainwater harvesting

DG: M, PG: 1	Part	Description	Part no.	Price €
	Plastic manhole cover Ø 500 mm	With two connections for pipe diameter 100 mm	53099	
	Calmed inlet	Supplies rainwater to the tank without turbulence. Connections for pipe diameter 100 mm and pipe diameter 125 mm	53111	
	Pipe couplers	For simple mounting of filter and pipe diameter 100 mm. 1 piece	53080	
	Downpipe filter Rainus	For roof area up to approx. 75 m ² . Suitable for downpipe diameter 100 mm	53081	
	Cartridge filter PF	For roof area up to approx. 210 m ² . Connections DN 100	53091	

Rainwater inner lining AR-SM with magnets



- Operation without vacuum type leak detector, no pressure, no current
- Easy and fast installation by means of powerful neodymium magnets
- Perfectly fitting, robust PVC lining

Application For conversion of cylindrical steel DIN tanks such as decommissioned fuel oil tanks, diesel tanks or storage tanks into reliable, high-grade rainwater storage tanks. No pressure or flow required. The rainwater inner lining AR-SM with magnets is suitable for storing rainwater in cylindrical steel tanks (3,000 to 50,000 litres).

Please note: In the case of coated steel tanks, verify that the attractive force of the magnets is sufficient.

Description The rainwater inner lining AR-SM allows owners to convert a decommissioned steel tank into a rainwater storage tank with very little effort.

The rainwater inner lining AR-SM is a PVC lining with flat, round, extremely powerful neodymium magnets welded into lateral and top areas. The lining is reliably held at the inner wall by the magnets - no pressure or power supply are required inside the tank. A tank can be conveniently converted into a rainwater storage tank: First, the tank is measured and then a precisely fitting lining is manufactured. The tank is prepared on the basis of a defined procedure (thorough cleaning of the tank, corrosion checks, etc.); depending on the condition of the tank, a fleece layer is placed on the tank floor for impact protection.

Then the lining is fitted in the steel tank and inflated by means of a blower; if necessary, the final fit is achieved by means of a vacuum pump. When the PVC lining is inflated, the magnets click into place at the inner wall exactly where planned. The fit of the PVC lining is checked and then it is fastened in the manhole by means of a fastening ring. The tank is ready for storing rainwater immediately after the lining and the piping connections have been installed.

Scope of delivery Rainwater inner lining AR-SM, made of plastic film Sikaplan® WP5140-08 black, film thickness 0.8 mm, for closed tanks, with all neodymium magnets welded into the film in the lateral and top areas, with film flange for the standard fastening ring.

i

Not only cylindrical DIN steel tanks, but certain steel tanks with different geometrical shapes can be converted into rainwater storage tanks. Please enquire separately.

i

Depending on the local conditions and on the tank, a fleece lining may be required in the bottom area of the tank as an impact protection. Different dome distances and special dimensions are manufactured at the same conditions.

	PG	Part no.	Price €
Extra charge for additional manhole			
500 mm	1	08027	
600 mm	1	08024	
Accessories (DG: H)			
Fastening ring Ø 500 mm	3	43900A	
Fastening ring Ø 600 mm	3	43900C	
Fleece LSV2 1 x 2 m plate	1	43952	
Bottom plate 800 x 800	1	43894	

DG: H, PG: 1	Part no.	Price €
3,000 l	43889.003	
5,000 l	43889.005	
7,000 l	43889.007	
10,000 l	43889.010	
13,000 l	43889.013	
15,000 l	43889.015	
16,000 l	43889.016	
20,000 l	43889.020	
25,000 l	43889.025	
30,000 l	43889.030	
50,000 l	43889.050	

Backup controller kit RENA for rainwater storage tanks



- Microprocessor-controlled supply of drinking water to rainwater tanks with connected water station
- Dry run protection and safety shutdown
- 2 program times for normal or increased water consumption
- Easy handling – fast installation



Application For monitoring rainwater tanks for sufficient water level. The backup controller RENA, consisting of control unit RENA, probe and solenoid valve, is designed for fully automatic supply of drinking water to rainwater tanks with connected water station. Continuous operation without frequent on and off cycles, two selectable program times for normal or increased water consumption, with leak monitoring, dry run protection and protection against deposits.

Description The complete backup controller kit consists of a control unit, indicators and controls and a Schuko CEE socket for connection of the water station, a probe for the water tank and a solenoid valve for connection to the water tap. If, as a result of insufficient precipitation or considerable water withdrawal, the level in the tank falls below a specific value, the solenoid valve is opened and fresh water from the drinking water mains system is supplied. 2 program times are selectable, depending on the water consumption (e.g. garden watering, car wash). In order to avoid the formation of deposits at the solenoid valve, the valve is opened and closed for one second three times in a row once per week. RENA features a safety shut-off system that responds to leaks in the tank or the pipes.

Technical specifications

Functions

Fully automatic backup controller for supplying drinking water to rainwater tanks with connected water station, with leak monitoring, dry run protection and protection against deposits

Control unit RENA

Control unit with microprocessor

Operating temperature range

Ambient: 0/40 °C

Schuko CEE socket

AC 230 V (fuse T 10 A)

Supply voltage

AC 230 V

Dimensions

W x H x D 100 x 188 x 65 mm

Degree of protection

IP 20 (EN 60529)

Solenoid valve

For drinking water and rainwater

W x H x D: 95 x 80 x 100 mm

Connection: G $\frac{1}{2}$ x G $\frac{3}{4}$

Flow rate: Max. 50 l/min

(inlet pressure 4 bar, open outlet)

Supply voltage: AC 230 V

Mains cable: 3 m

Degree of protection IP 65 (EN 60529)

Level probe

For drinking water and rainwater

Supply voltage: AC 6 V

Scope of delivery RENA backup controller kit

- Control unit RENA
- Level probe RENA with 15 m probe cable
- Solenoid valve (G $\frac{1}{2}$ x G $\frac{3}{4}$) with 3 m mains cable
- Operating instructions

10

DG: H, PG: 4			Part no.	Price €
RENA backup controller kit, complete	1	-	53100	
Control unit RENA	1	-	53101	
Level probe RENA with 15 m probe cable	1	-	53102	
Level probe RENA with 25 m probe cable	1	-	53122	
Solenoid valve G$\frac{1}{2}$ x G$\frac{3}{4}$	1	-	53134	



Pressure gauges for heating installations



Capsule pressure gauge / pressure gauge accessories



Pressure gauges for differential pressure



Pressure gauges and thermometers with capillary tube

CHAPTER 11

Mechanical pressure measuring instruments (pressure gauges)

OVERVIEW

Mechanical pressure measuring instruments at a glance	312
Pressure transducers at a glance	314
Technical information pressure gauges	316
Pressure gauges with capillary tube	322

BOURDON TUBE PRESSURE GAUGES

Bourdon tube pressure gauges for boiler and heating system applications	317
Bourdon tube pressure gauges for heating/plumbing applications	319
Bourdon tube pressure gauges with plastic capillary tube	323
Bourdon tube pressure gauges with copper capillary tube	328
Bourdon tube pressure gauges for industrial applications	333
Standard Bourdon tube pressure gauges for differential pressure	336

CAPSULE PRESSURE GAUGES

Standard capsule pressure gauges	337
----------------------------------	-----

ACCESSORIES FOR PRESSURE GAUGES

Shut-off cocks/valves for pressure gauges	339
Overpressure safety device, pressure gauge push-button stop cock	341
Accessories for pressure gauges	342

Mechanical pressure measuring instruments at a glance



		Standard capsule pressure gauges	Capsule pressure gauges for chemical applications	Standard Bourdon tube pressure gauges/ Bourdon tube pressure gauges for industrial applications	Bourdon tube pressure gauges / stainless steel pressure gauges Bourdon tube pressure gauges for chemical applications
NG 40	Housing size			•	•
NG 50				•	•
NG 63		•	•	•	•
NG 80		•		•	•
NG 100		•	•	•	•
NG 160		•	•	•	•
NG 250				•	
Bottom process connection		•	•	•	•
Centre back process connection		•	•	•	•
Process connection both ends					
-25/0 mbar to -1000/0 mbar	Ranges	•	•	• (-1 bar)	• (-1 bar)
0/25 mbar to 0/1000 mbar		•	•		
0/0.6 bar to 0/1600 bar				• (max. 1,000 bar)	•
0/2500 bar to 0/4000 bar					Pressure gauges for high pressures
0/10 mbar to 0/25 bar					
≥ Class 1.6	Accuracy	•	•	•	•
≥ Class 1.0		•**		•	•
≥ Class 0.6				Precision pressure gauges	Precision pressure gauges
≥ Class 0.25				Precision pressure gauges	
Operating temperature range -20/+60 °C	Application areas	•		•	
Operating temperature range -20/+100 °C			•		•**
Operating temperature range -20/+150 °C					•**
Relative pressure measurement	Application areas	•	•	•	•
Differential pressure measurement		•		•	•
Measurement of gases		•	•	•	•
Measurement of liquids				•	•
Crystallising media				•*	•*
Thermal engineering/pneumatics		•	•	•	•
Process engineering		•	•	•	•
Housing filling (glycerine, paraffin)				•**	•
Safety version				Safety pressure gauges	
Electrical contact	Options/extra equipment			•**	•**
Overload safety 10 x FSD		•			
Back flange		•	•	•	•
Clamp fixing		•	•	•	•
3-hole fixing, panel mounting bezel		•	•	•	•
Damping screw		•	•	•	•
Reference pointer		•	•	•	•
Maximum pointer		≥ 250 mbar	≥ 250 mbar	•	•
Special scale		•	•	•	•
Bezel for panel mounting				•	•

* Only in connection with chemical seal.
** Depending on version.



		DMU 600/20	DMU 01	DMU 02	DMU 02 Vario	DMU 03	DMU 04	DMU 05 P	DMU 07
Smallest measuring range		0/4 bar	0/1 bar	0/600 mbar	0/1 bar	0/100 mbar	0/100 mbar	0/100 mbar	0/40 mbar
Largest measuring range		0/40 bar	0/400 bar	0/2,000 bar	0/1000 bar	0/600 bar	0/400 bar	0/600 bar	0/20 bar
4–20 mA / HART	Output	•/-	•/-	•/-	•/-	•/-	•/-	•/-	•/-
0–10 V		•	•	•	•	•	•	•	•
≤ ±1 % FSO	Accuracy	•							
≤ ±0.5 % FSO			•	•					
≤ ±0.35 % FSO					•	•	•		•
≤ ±0.1 % FSO								•	
Stainless steel	Wetted parts			•	•				
Stainless steel, FKM						•	•	•	
Stainless steel, ceramic (AL ₂ O ₃), FKM			•						•
Stainless steel, silicon, glass, silicone		•							
Aluminium, silicon, glass, silicone, PUR									
No pressure transmission liquid	Pressure transmission	•	•	•					•
Paraffin oil, FDA					•		•		
Silicone oil						•		•	
Connection thread	Process connection	•	•	•	•	•	•	•	•
Hygienic connections					•		•		
Flanges					•				
Submersible probes									
ISO 4400 connector	Electrical connection	•	•	•	•	•	•	•	•
M12 x 1		•	•	•	•	•	•	•	•
Fixed cable connection		•	•	•		•	•	•	•
Cable gland									•
Temperature of the medium ≥ 100 °C	Application area		•	•	•	•	•	•	•
Temperature of the medium < 100 °C		•							
Temperature of the medium < -25 °C		•	•				•	•	•
Temperature of the medium ≥ -25 °C				•	•	•			•
Measuring range spread	Evaluation				•				
Indication of measured values									
ATEX certificate				•		•	•	•	•
SIL assessment			•***			•	•		
Negative pressure (vacuum)	Application areas	•	•	•	•	•	•	•	•
Relative pressure measurement		•	•	•	•	•	•	•	•
Absolute pressure measurement		•	•			•	•	•	•
Differential pressure measurement									
Measurement of water / waste water		•	•	•	•	•	•	•	•
Measurement of oils		•	•	•	•	•	•	•	•
Measurement of chemicals				•	•				•
Measurement of food					•		•		
Measurement of pharmaceuticals					•		•		
Measurement of crystallising media					•				•
Measurement of gases		•	•	•	•	•	•	•	•
Measurement of liquids		•	•	•	•	•	•	•	•

* Depends on measuring range.
 ** Accuracy of mechanical local display.
 *** Depends on version.

Pressure gauges – Mechanical pressure measuring instruments with elastic measuring elements



Bourdon tube pressure gauge

The measuring element of a Bourdon tube pressure gauge is a C shaped or helical metal tube closed at one end. For pressure ranges up to a maximum of 60 bar, the tube has an oval cross section and the shape of a C. For higher pressure ranges, the tube is bent into the shape of a helix. The oval cross section is obtained during bending. When pressure is applied, both types of bent tubes try to regain their original shapes, the straight tube. In this process, the radius increases and this displacement is converted into a circular movement by the movement. Bourdon tube pressure gauges are suitable for a wide variety of applications in measuring liquids and gases; they are the most commonly used pressure gauges. They are used for pressure measurements from 600 mbar up to several 1000 bar.



Capsule pressure gauge

Capsule pressure gauges are used in gas technology applications for low pressure ranges. Two concentrically shaped diaphragms are connected at the outer edges by means of welding or soldering. One diaphragm has an opening in the centre through which the gas to be measured can flow in. The pressure in the capsule causes it to arch to the outside. A deflection lever at the opposite side of the inlet opening transmits the linear displacement to a movement and converts it into a rotary movement. As early as in the 1920s, AFRISO patented this system as the "fine pressure gauge". Capsule pressure gauges are exclusively used for dry and clean gases at measuring ranges from 6 mbar to 1,000 mbar.



Diaphragm pressure gauge

Diaphragm pressure gauges use a concentrically shaped diaphragm which is directly connected to the process connection. The pressure is applied to the process side of the diaphragm. A rod at the opposite side which is fitted with a movement converts the displacement of the diaphragm into a rotary movement. Diaphragm pressure gauges are used for gaseous and liquid media within the range from 10 mbar to 25 bar; the media can even be viscous or crystallising if the process connection opening (open flange) is sufficiently large.

With a flush welded diaphragm, they are ideal for measurements in hygienic processes.

11



Spring-diaphragm pressure gauges

Spring-diaphragm pressure gauges are ideal for measuring low differential pressures at high static pressures. The pressures act on two pressure chambers separated by an elastic diaphragm. If there are different pressures in the chambers, the diaphragm is axially displaced against a compression spring. This displacement is transmitted to a movement by a rod and converted into a rotary movement. The differential pressure is directly indicated by a pointer. The diaphragm is held by a metallic support which results in an overpressure safety of up to 25 bar at both sides. Diaphragm pressure gauges are used for liquids that are not highly viscous and for differential pressure from 250 mbar to 25 bar.

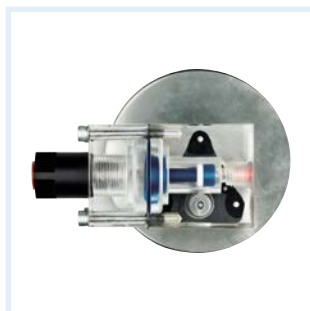

Magnetic piston and magnetic diaphragm pressure gauges

Magnetic piston type pressure gauges and magnetic diaphragm pressure gauges are primarily used for measuring differential pressure at filters which are subject to high static pressures. The pressures act on two pressure chambers separated by a diaphragm and/or a piston. If there are different pressures in the chambers, a rod with a permanent magnet is axially displaced against a compression spring. The permanent magnet transmits this displacement to the pointer by means of a ring magnet mounted to the pointer hub. The pointer indicates the pressure difference. Magnetic piston pressure gauges and magnetic diaphragm pressure gauges are used for the measurement of differential pressure of gases from 2.5 mbar to 10 bar; a static pressure of up to 350 bar is permissible.

Bourdon tube pressure gauges for boiler and heating system applications



- Design as per EN 837-1
- Corrosion-resistant, highly impact-resistant plastic housing
- Many customised versions available



Version: Plastic connection

Application For gaseous and liquid media which are not highly viscous, do not crystallise and do not attack copper alloys and plastic. For measuring gas or vapour, these gauges must be used in accordance with the table "Selection Criteria as per EN 837-2" (see appendix)!

Technical specifications

Type

D 1

Nominal size

26 – 28

Accuracy class (EN 837-1/6)

4.0

Range (EN 837-1/5)

0/4 bar

Application area

Static load: $\frac{3}{4}$ x full scale value
 Dynamic load: $\frac{2}{3}$ x full scale value
 Short-term: full scale value

Operating temperature range

Medium: $T_{max} = +60\text{ °C}$
 Ambient: $T_{min} = -20\text{ °C}$
 $T_{max} = +60\text{ °C}$

Temperature performance

Indication error when the temperature of the measuring system deviates from the normal temperature of 20 °C:
 rising temperature approx. $\pm 0.4\%$ /10 K
 falling temperature approx. $\pm 0.4\%$ /10 K
 of full scale value

Degree of protection

IP 32 (EN 60529)

Standard version

Connection

Axial
 Plastic, integrated in housing:
 RF 26 = G $\frac{1}{8}$ B
 RF 28 = M 10 x 1
 Brass: G $\frac{1}{8}$ B, M 10 x 1

Measuring element

Bourdon tube, copper alloy
 "C" type tube

Movement

Brass

Dial

Plastic (ABS), white
 Dial marking black

Pointer

Plastic, black

Housing

RF 26 = Plastic (PA6), black
 RF 28 = Plastic (PA6), white,
 back flange

Window

Clip-in plastic

Options

- Special scales
- Reference pointer
- Other brass connection

DG: G, PG: 4	Price €
RF 26, plastic connection G$\frac{1}{8}$B	
RF 26, brass connection G$\frac{1}{8}$B	
RF 28, plastic connection M10 x 1	
RF 28, brass connection M10 x 1	

Minimum order quantity = 100 pieces per delivery.

Bourdon tube pressure gauges for boiler and heating system applications

Type D 1 – RF 26/28

Housing types and dimensions (mm)

RF 26 plastic connection, integrated in housing

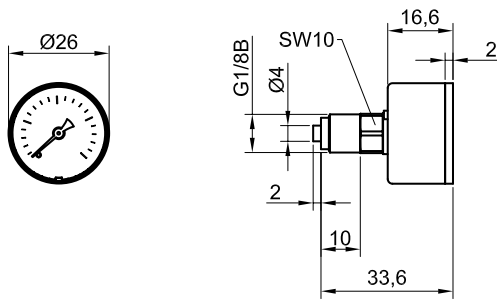

RF 26 Brass connection

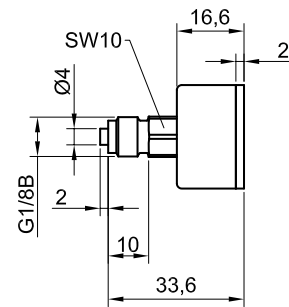

RF 28 plastic connection, integrated in housing

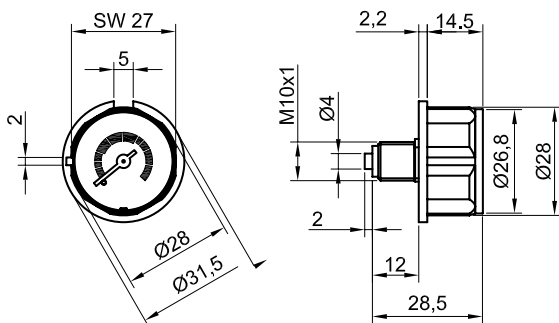

RF 28 Brass connection

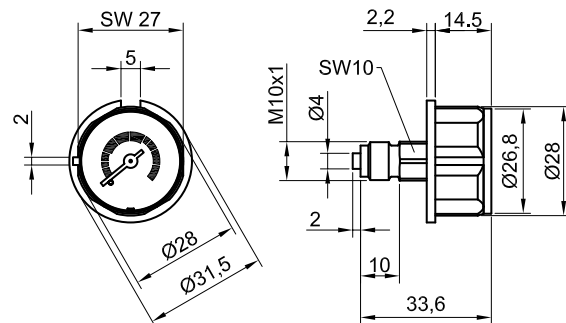

Bourdon tube pressure gauges for heating/plumbing applications



- With self-sealing connection thread (NG 50 and 63) for fast mounting
- Red maximum mark on dial (version HZ)
- Adjustable red reference pointer and green operation segment on window (version HZ)
- Corrosion-resistant housing



Page 339



Mounting valves with self-sealing coating, automatically close during replacement of gauge to enable fast and cost-effective servicing (see "Accessories for pressure gauges").

Application For gaseous and liquid media which are not highly viscous, do not crystallise and do not attack copper alloys and EPDM.
! For measuring gas or vapour, observe the table "Selection Criteria as per EN 837-2" (see appendix!)

Technical specifications

Nominal size
50 – 63 – 80 – 100

Accuracy class (EN 837-1/6)
2.5

Ranges (EN 837-1/5)
-1/0 bar
0/0.6 to 0/25 bar

Application area
Static load: $\frac{3}{4}$ x full scale value
Dynamic load: $\frac{2}{3}$ x full scale value
Short-term: full scale value

Operating temperature range

Medium: $T_{\max} = +60\text{ }^{\circ}\text{C}$
Ambient: $T_{\min} = -20\text{ }^{\circ}\text{C}$
 $T_{\max} = +60\text{ }^{\circ}\text{C}$

Temperature performance

Indication error when the temperature of the measuring system deviates from the normal temperature of $20\text{ }^{\circ}\text{C}$:
rising temperature approx. $\pm 0.4\text{ } \%/10\text{ K}$
falling temperature approx. $\pm 0.4\text{ } \%/10\text{ K}$
of full scale value

Degree of protection

IP 32 (EN 60529)

Standard version

Connection

NG 50–63 G $\frac{1}{4}$ B: Self-sealing thread with PTFE ring for safe and fast installation (Attention: 60° chamfer required at female thread!)
Brass, bottom or centre back
NG 50–63 G $\frac{1}{4}$ B – spanner size SW 14
NG 80–100 G $\frac{1}{2}$ B – spanner size SW 22

Measuring element

Bourdon tube, copper alloy; "C" type tube

Movement

Brass

Dial

Plastic, white
Dial marking black

Pointer

Plastic, black

Housing

Plastic (ABS), black, highly impact-resistant and corrosion-resistant

Window

Clip-in plastic NG 80–100 with adjustable red reference pointer

Special versions

Pressure gauges for heating installations NG 50–63–80

For sealed heating systems
Range: 0/4 bar
Connection: NG 50 G $\frac{1}{4}$ B bottom back
NG 63 G $\frac{1}{4}$ B or G $\frac{3}{8}$ B bottom or centre back
NG 80 G $\frac{1}{2}$ B bottom or G $\frac{1}{4}$ B centre back (with valve G $\frac{1}{4}$ x G $\frac{1}{2}$)
Dial with red mark at 2.5 or 3 bar and green sector from 1.5 to 2.5 or 3 bar, window with adjustable red reference pointer and green flag

Hydrometer NG 80–100

Water level indicator for open heating systems
Ranges: 0/0.6 to 0/10 bar
Connection: Brass G $\frac{1}{2}$ B bottom – SW 22
Dual scale: Bar outer scale black
metres water column inner scale black
Window with adjustable reference pointer



See page 321 for prices.

Bourdon tube pressure gauges for heating/plumbing applications

Housing types and dimensions

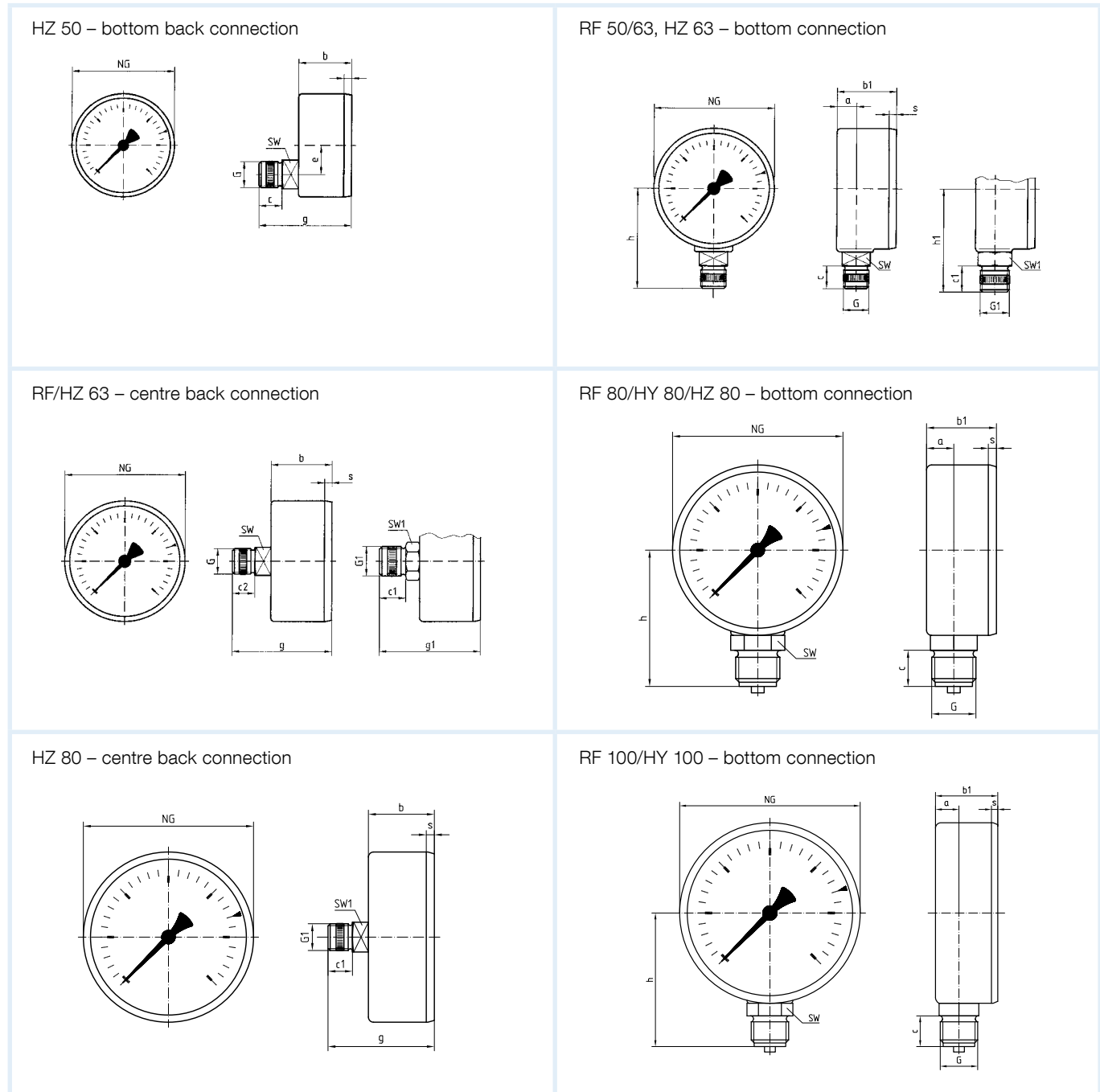





11

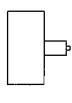
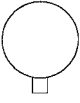
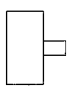

Dimensions (mm)

Nominal size (NG)	a	b	b1	c	c1	c2	e	g	g1	G	G1	h	h1	s	SW	Spanner size SW1
50	-	25.8	-	11.2	-	-	14	43	-	G $\frac{1}{4}$ B	-	-	-	3.8	14	-
63	9.8	30.4	29.7	11.2	13	11.5	-	49.9	50.4	G $\frac{1}{4}$ B	G $\frac{3}{8}$ B	49.5	51.5	3.7	14	17
80	12.8	31	32.8	17	11.5	-	-	50	-	G $\frac{1}{2}$ B	G $\frac{1}{4}$ B	64	-	2.8	22	14
100	15.5	-	34.5	17	-	-	-	-	-	G $\frac{1}{2}$ B	-	74	-	3.5	22	-

Bourdon tube pressure gauges for heating/plumbing applications

DG: G, PG: 2

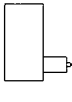
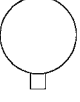
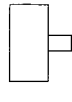
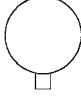
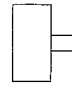
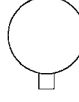
Type	RF 50 rad	RF 50 ax	RF 63 rad	RF 63 ax	RF 80 rad	HY 80 rad*	RF 100 rad	HY 100 rad*
Version								
Housing Ø	50	50	63	63	80	80	100	100
Housing	Plastic (ABS), black, highly impact-resistant and corrosion-resistant							
Measuring element	Bourdon tube, copper alloy							
Accuracy class	2.5	2.5	2.5	2.5	2.5	2.5	2.5	2.5
Connection	G¼B	G¼B	G¼B	G¼B	G½B	G½B	G½B	G½B
Thread	Self-sealing with PTFE sealing ring				-			
					With adjustable red reference pointer			
Range (bar)	Part no.	Part no.	Part no.	Part no.	Part no.	Part no.	Part no.	Part no.
Price €								
-1/0	-	-	63501	-	63551	-	63601	-
0/0.6	-	-	-	-	-	-	-	63281
0/1	-	-	-	-	63559	63570	63609	63282
0/1.6	-	-	-	-	63560	63571	63610	63283
0/2.5	-	-	63511	63536	63561	-	63611	63284
0/4	-	-	63512	63537	63562	-	63612	63285
0/6	63122	63127	63513	63538	63563	63574	63613	63286
0/10	63123	63128	63514	63539	63564	63575	63614	63287
0/16	63124	63129	63515	63540	63565	-	63615	-
0/25	-	-	-	-	63566	-	63616	-

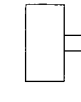
Type	HZ 50 back bottom	HZ 63 rad	HZ 63 ax	HZ 63 rad	HZ 63 ax	HZ 80 rad	HZ 80 rad	HZ 80 ax
Version								
Housing Ø	50	63	63	63	63	80	80	80
Housing	Plastic (ABS), black, highly impact-resistant and corrosion-resistant							
Measuring element	Bourdon tube, copper alloy							
Range	0/4 bar							
Dial	With red mark at 3 bar and green sector from 1.5 to 3 bar							
Window	Plastic with adjustable red reference pointer and green flag							
Accuracy class	2.5	2.5	2.5	2.5	2.5	2.5	2.5	2.5
Connection	G¼B	G¾B	G¾B	G¼B	G¼B	G½B	G¼ with valve G¼ x G½	G¼ with valve G¼ x G½
Thread	Self-sealing with PTFE sealing ring					-		Self-sealing with PTFE sealing ring
Range (bar)	Part no.	Part no.	Part no.	Part no.	Part no.	Part no.	Part no.	Part no.
Price €								
Part no.	63927	63910	63914	63911	63915	63918	63913	63919
Dial	With red mark at 2.5 bar and green sector from 1.5 to 2.5 bar							
Price €								
Part no.	-	63908	63909	-	-	-	-	-

* Dual scale bar/mWC.

Pressure gauges with capillary tube

For burners, boiler, hot water tanks and air conditioning/refrigeration systems, AFRISO offers different pressure and temperature measuring instruments with various housing versions and connection types. The portfolio covers cost-effective pressure gauges and thermometers with plastic or copper capillaries as well as combination instruments such as combined thermometer/pressure gauges. We also provide OEM versions for your specific applications. Please enquire.

Application examples



11

i

See page 354 for thermometers with capillary tube.

Pressure gauges with plastic capillary tube



- Ideal for boilers and burners, especially for wall-mounted boilers
- Corrosion-resistant, highly impact-resistant plastic housing
- Many customised versions available

Application For gaseous and liquid media which are not highly viscous, do not crystallise and do not attack copper alloys and plastic. For measuring gas or vapour, these gauges must be used in accordance with the table "Selection Criteria as per EN 837-2" (see appendix)!

Technical specifications

Type

D 1

Nominal size

26 – 28 – 37 – 40 – 42 – 52 – 45 x 45

Accuracy class (EN 837-1/6)

4.0

Ranges (EN 837-1/5)

0/4 bar
0/6 bar

Application area

Static load: $\frac{3}{4}$ x full scale value
Dynamic load: $\frac{2}{3}$ x full scale value
Short-term: full scale value

Operating temperature range

Medium: $T_{\max} = +80\text{ °C}$
Ambient: $T_{\min} = -20\text{ °C}$
 $T_{\max} = +70\text{ °C}$

Temperature performance

Indication error when the temperature of the measuring system deviates from the normal temperature of 20 °C:
rising temperature approx. $\pm 0.4\text{ ‰}/10\text{ K}$
falling temperature approx. $\pm 0.4\text{ ‰}/10\text{ K}$
of full scale value

Degree of protection

IP 32 (EN 60529)

Standard version

Connection

Back, with plastic capillary
Brass disk G $\frac{1}{4}$ B

Measuring element

Bourdon tube, copper alloy
"C" type tube

Movement

Brass

Dial

Plastic (ABS), white or black
Dial marking black

Pointer

Plastic, black or white

Housing

Plastic (ABS), white, black or grey
Highly impact-resistant and corrosion-resistant
RFK 26, RFK 28 = Plastic (PA6)
glass-fibre reinforced

Window

Clip-in plastic, transparent
RFK 52 with bezel

Capillary length

Plastic capillary, R3, black
L = 500, 1000, 1500, 2000 mm

Options

- Window with reference pointer (RFK 28, 37, 45, 52)
- Special scale
- Dial with customer logo
- Other process connections
- Various capillary lengths
- Special colours for housing, dial, pointer



See page 326 for prices.

Pressure gauges with plastic capillary tube

Dimensions (in mm)

Type RFK 26

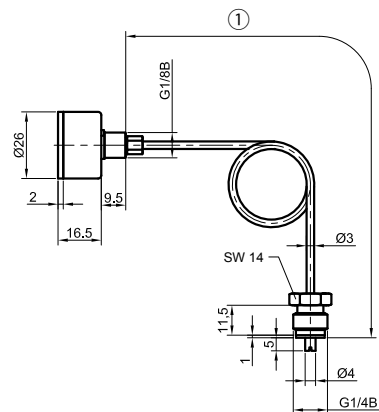

① Capillary length

Type RFK 28

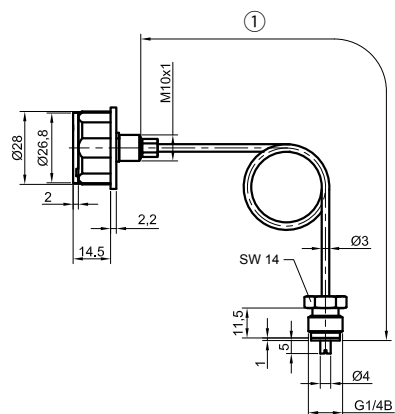

① Capillary length

Type RFK 37

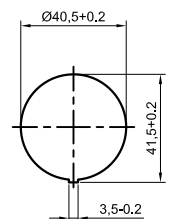
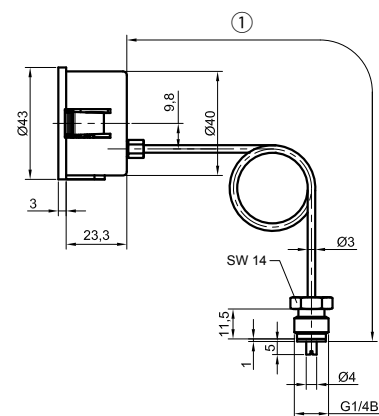

① Capillary length

Type RFK 40

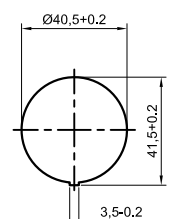
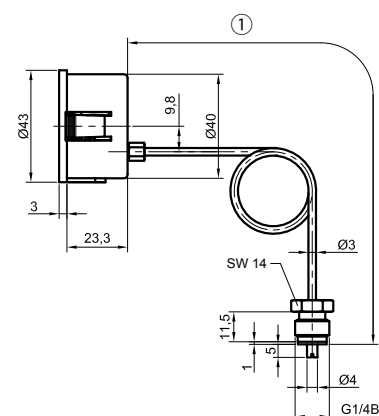

① Capillary length

Pressure gauges with plastic capillary tube

Dimensions (in mm)

Type RFK 42

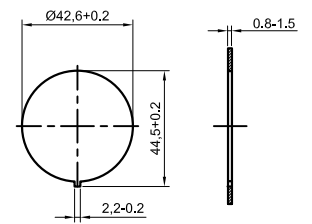
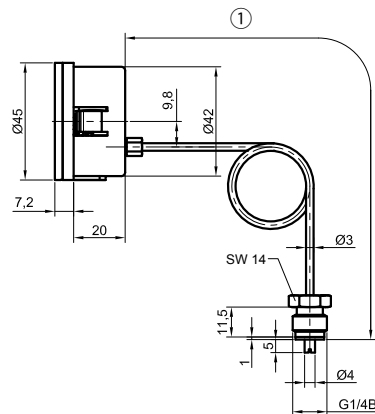

① Capillary length

Type RFK 45

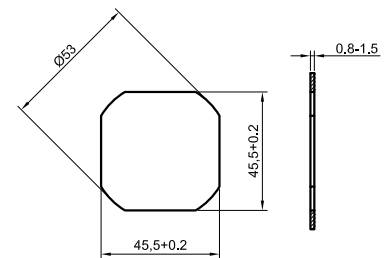
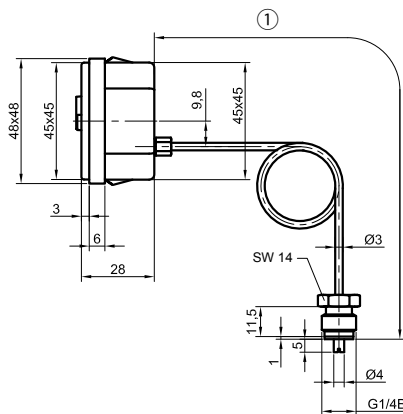

① Capillary length



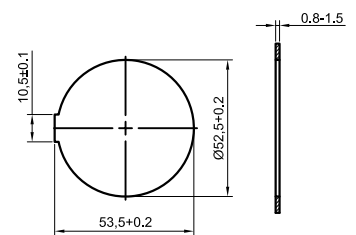
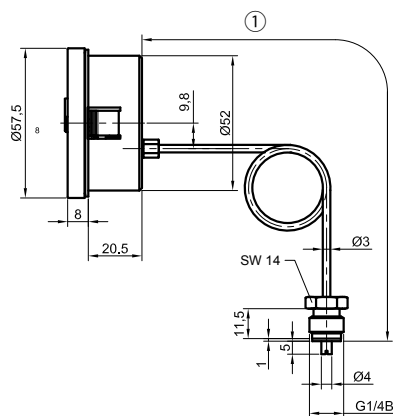

Type RFK 52



① Capillary length

Pressure gauges with plastic capillary tube

DG: G, PG: 2



Type	RFK 26	RFK 28	RFK 37	RFK 40
Version				
Housing Ø	26	28	37	40
Housing	Plastic (PA6), black	Plastic (PA6), white	Plastic (ABS), white	
Pointer	Plastic, black			
Dial/scale	Dial white / scale black			
Packing unit**	72 pieces			
Range	0/4 bar	0/4 bar	0/4 bar	0/4 bar
Capillary length*	Price € Part no.	Price € Part no.	Price € Part no.	Price € Part no.
500 mm				
1,000 mm				
1,500 mm				
2,000 mm				
Range	---	---	0/6 bar	0/6 bar
Capillary length*	Price € Part no.	Price € Part no.	Price € Part no.	Price € Part no.
500 mm	---	---		
1,000 mm	---	---		
1,500 mm	---	---		
2,000 mm	---	---		

* Other capillary lengths on request.

** Minimum order quantity for non-stock items = 144 pieces per delivery.

Pressure gauges with plastic capillary tube

DG: G, PG: 2

Type	RFK 42	RFK 45	RFK 52
Version			
Housing Ø	42	45 x 45	52
Housing	Plastic (ABS), white	Plastic (ABS), black	Plastic (ABS), grey, with bezel, black
Pointer	Plastic, black	Plastic, white	
Dial/scale	Dial white / scale black	Dial white / scale black	
Packing unit**	72 pieces	72 pieces	50 pieces
Range	0/4 bar	0/4 bar	0/4 bar
Capillary length*	Price € Part no.	Price € Part no.	Price € Part no.
500 mm			
1,000 mm			
1,500 mm			
2,000 mm			
Range	0/6 bar	0/6 bar	0/6 bar
Capillary length*	Price € Part no.	Price € Part no.	Price € Part no.
500 mm			
1,000 mm			
1,500 mm			
2,000 mm			

* Other capillary lengths on request.

** Minimum order quantity = 2 packing units.

Pressure gauges with copper capillary tube



- Ideal for boilers and burners, especially for wall-mounted boilers
- Corrosion-resistant, highly impact-resistant plastic housing
- Many customised versions available

Application For gaseous and liquid media which are not highly viscous, do not crystallise and do not attack copper alloys and plastic. For measuring gas or vapour, these gauges must be used in accordance with the table "Selection Criteria as per EN 837-2" (see appendix)!

Technical specifications

Type

D 1

Nominal size

26 – 28 – 37 – 40 – 42 – 52 – 45 x 45

Accuracy class (EN 837-1/6)

4.0

Ranges (EN 837-1/5)

0/4 bar

0/6 bar

Application area

Static load: $\frac{1}{4}$ x full scale value

Dynamic load: $\frac{2}{3}$ x full scale value

Short-term: full scale value

Operating temperature range

Medium: $T_{\max} = +80\text{ °C}$

Ambient: $T_{\min} = -20\text{ °C}$

$T_{\max} = +70\text{ °C}$

Temperature performance

Indication error when the temperature of the measuring system deviates from the normal temperature of 20 °C:
 rising temperature approx. $\pm 0.4\text{ ‰}/10\text{ K}$
 falling temperature approx. $\pm 0.4\text{ ‰}/10\text{ K}$
 of full scale value

Degree of protection

IP 32 (EN 60529)

Standard version

Connection

Back, with copper capillary

Brass disk G $\frac{1}{4}$ B

Measuring element

Bourdon tube, copper alloy

"C" type tube

Movement

Brass

Dial

Plastic (ABS), white or black

Dial marking black

Pointer

Plastic, black or white

Housing

Plastic (ABS), white, black or grey

Highly impact-resistant and corrosion-resistant
 RFK 26, RFK 28 = Plastic (PA6)
 glass-fibre reinforced

Window

Clip-in plastic, transparent

RFK 52 with bezel

Capillary length

Cu capillary with PVC coating, R3, grey

L = 500, 1000, 1500, 2000 mm

Options

- Window with reference pointer (RFK 28, 37, 45, 52)
- Special scales
- Dial with customer logo
- Other process connections
- Various capillary lengths
- Special colours for housing, dial, pointer



See page 331 for prices.

Pressure gauges with copper capillary tube

Dimensions (in mm)

Type RFK 26

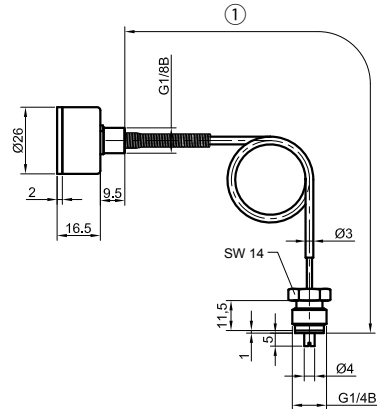

① Capillary length

Type RFK 28

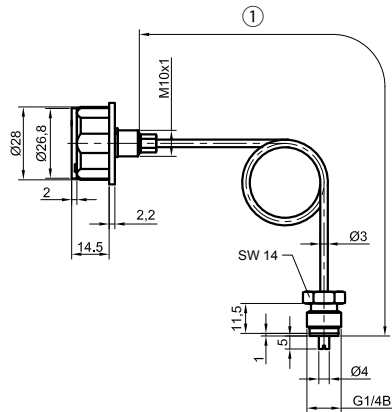

① Capillary length

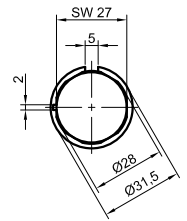

Type RFK 37

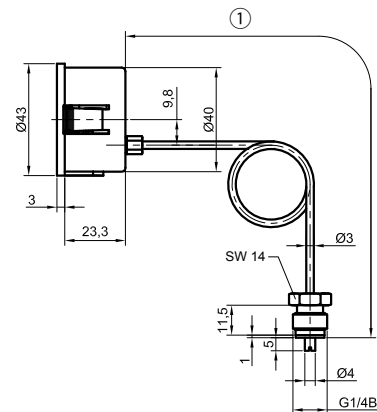
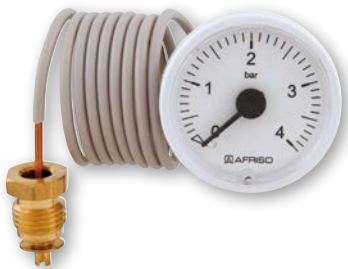

① Capillary length

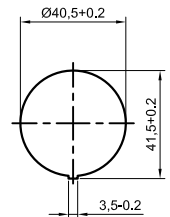

Type RFK 40

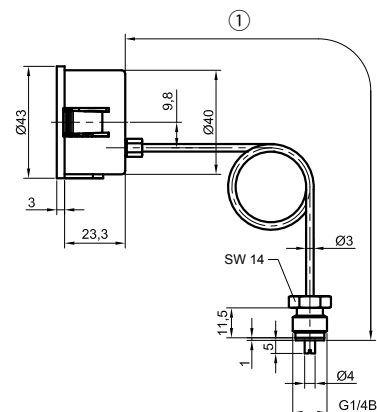
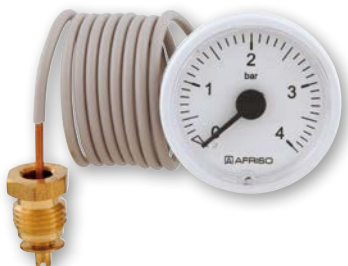

① Capillary length

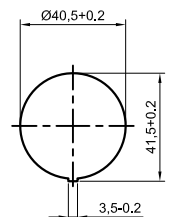

Pressure gauges with copper capillary tube

Dimensions (in mm)

Type RFK 42

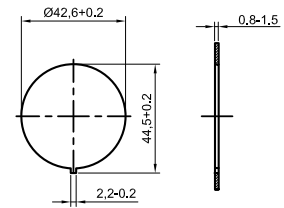
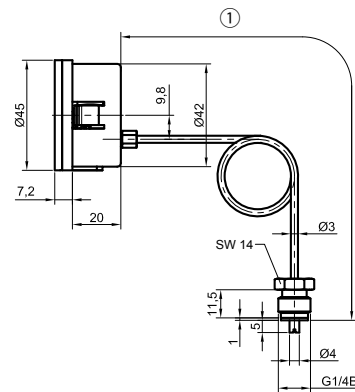
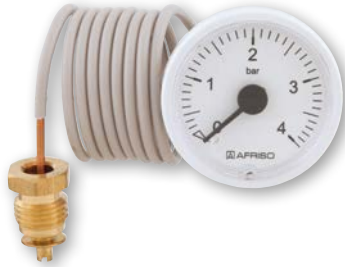

① Capillary length

Type RFK 45

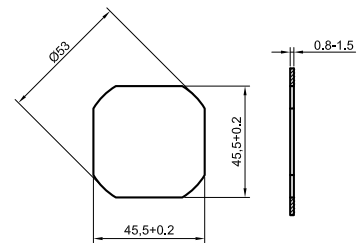
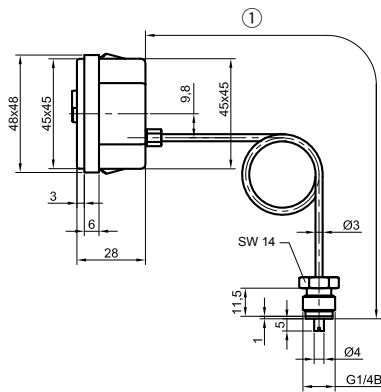

① Capillary length



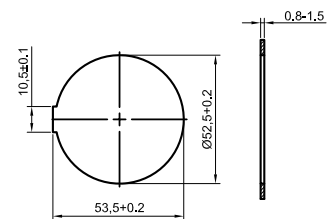
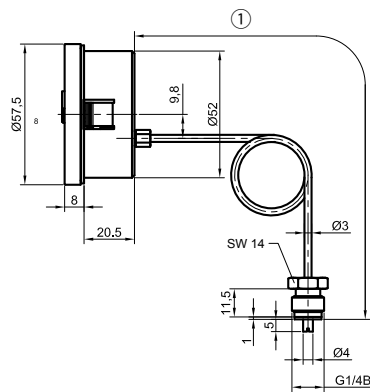

Type RFK 52



① Capillary length

Pressure gauges with copper capillary tube

DG: G, PG: 2



Type	RFK 26	RFK 28	RFK 37	RFK 40
Version				
Housing Ø	26	28	37	40
Housing	Plastic (PA6), black	Plastic (PA6), white	Plastic (ABS), white	
Pointer	Plastic, black			
Dial/scale	Dial white / scale black			
Packing unit**	50 pieces			
Range	0/4 bar	0/4 bar	0/4 bar	0/4 bar
Capillary length*	Price € Part no.	Price € Part no.	Price € Part no.	Price € Part no.
500 mm				
1,000 mm				
1,500 mm				
2,000 mm				
Range	---	---	0/6 bar	0/6 bar
Capillary length*	Price € Part no.	Price € Part no.	Price € Part no.	Price € Part no.
500 mm	---	---		
1,000 mm	---	---		
1,500 mm	---	---		
2,000 mm	---	---		

* Other capillary lengths on request.

** Minimum order quantity = 100 pieces per delivery.

Pressure gauges with copper capillary tube

DG: G, PG: 2

Type	RFK 42	RFK 45	RFK 52
Version			
Housing Ø	42	45 x 45	52
Housing	Plastic (ABS), white	Plastic (ABS), black	Plastic (ABS), grey, with bezel, black
Pointer	Plastic, black	Plastic, white	
Dial/scale	Dial white / scale black	Dial white / scale black	
Packing unit**	72 pieces	72 pieces	50 pieces
Range	0/4 bar	0/4 bar	0/4 bar
Capillary length*	Price € Part no.	Price € Part no.	Price € Part no.
500 mm			
1,000 mm			
1,500 mm			
2,000 mm			
Range	0/6 bar	0/6 bar	0/6 bar
Capillary length*	Price € Part no.	Price € Part no.	Price € Part no.
500 mm			
1,000 mm			
1,500 mm			
2,000 mm			
Range	---	---	0/10 bar
Capillary length*	Price € Part no.	Price € Part no.	Price € Part no.
500 mm	---	---	
1,000 mm	---	---	
1,500 mm	---	---	
2,000 mm	---	---	

* Other capillary lengths on request.

** Minimum order quantity = 2 packing units.

Bourdon tube pressure gauges for industrial applications



EN 837-1



- For machine and plant engineering
- Robust, stainless steel housing with bayonet bezel
- Optionally available up to nominal size 250 mm
- Can be equipped with electrical contact
- DNV-GL- and GOSSTANDART-certified

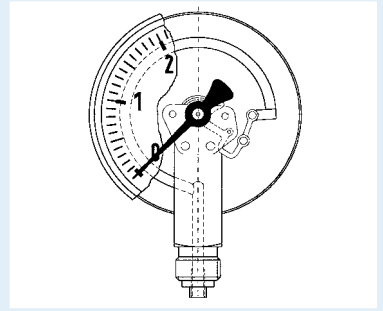

Application For gaseous and liquid media which are not highly viscous, do not crystallise and do not attack copper alloys. For high accuracy and rough application conditions.
! For measuring gas or vapour, observe the table "Selection Criteria as per EN 837-2" (see appendix)!

Technical specifications

Type
D 4

Nominal size
100 – 160

Accuracy class (EN 837-1/6)
1.0

Ranges (EN 837-1/5)
-1/0 to -1/+15 bar
0/0.6 to 0/1000 bar

Application area
Static load:
≤ 600 bar = full scale value
> 600 bar = ¾ x full scale value
Dynamic load:
≤ 600 bar = 0.9 x full scale value
> 600 bar = 2/3 x full scale value

Short-term:
≤ 600 bar = 1.3 x full scale value
> 600 bar = full scale value

Operating temperature range
Medium: $T_{max} = +60\text{ °C}$
Ambient: $T_{min} = -20\text{ °C}$
 $T_{max} = +60\text{ °C}$

Temperature performance
Indication error when the temperature of the measuring system deviates from the normal temperature of 20 °C:
rising temperature approx. ±0.4 %/10 K
falling temperature approx. ±0.4 %/10 K
of full scale value

Degree of protection
IP 54 (EN 60529)

Standard version

Connection
Brass, bottom or bottom back
G½B – spanner size SW 22 (EN 837-1/7.3)

Measuring element
Bourdon tube, ≤ 60 bar "C" type tube, copper alloy > 60 bar helical tube, stainless steel 316 Ti/316 L

Movement
Brass

Dial
Aluminium, white; dial marking black

Pointer
Aluminium, black

Housing
Stainless steel 304
with blow-out

Bayonet type bezel
Stainless steel 304

Window
Instrument glass

- Options**
- Nominal size 250 (bottom connection)
 - Back flange
 - Panel mounting bezel
 - 3-hole fixing, panel mounting bezel
 - Laminated safety glass window

- Damping screw
- Reference pointer
- Electrical contacts
- Special scales
- Other process connections



See page 335 for prices.

Bourdon tube pressure gauges for industrial applications

Type D 4 – NG 100/160

Housing types and dimensions

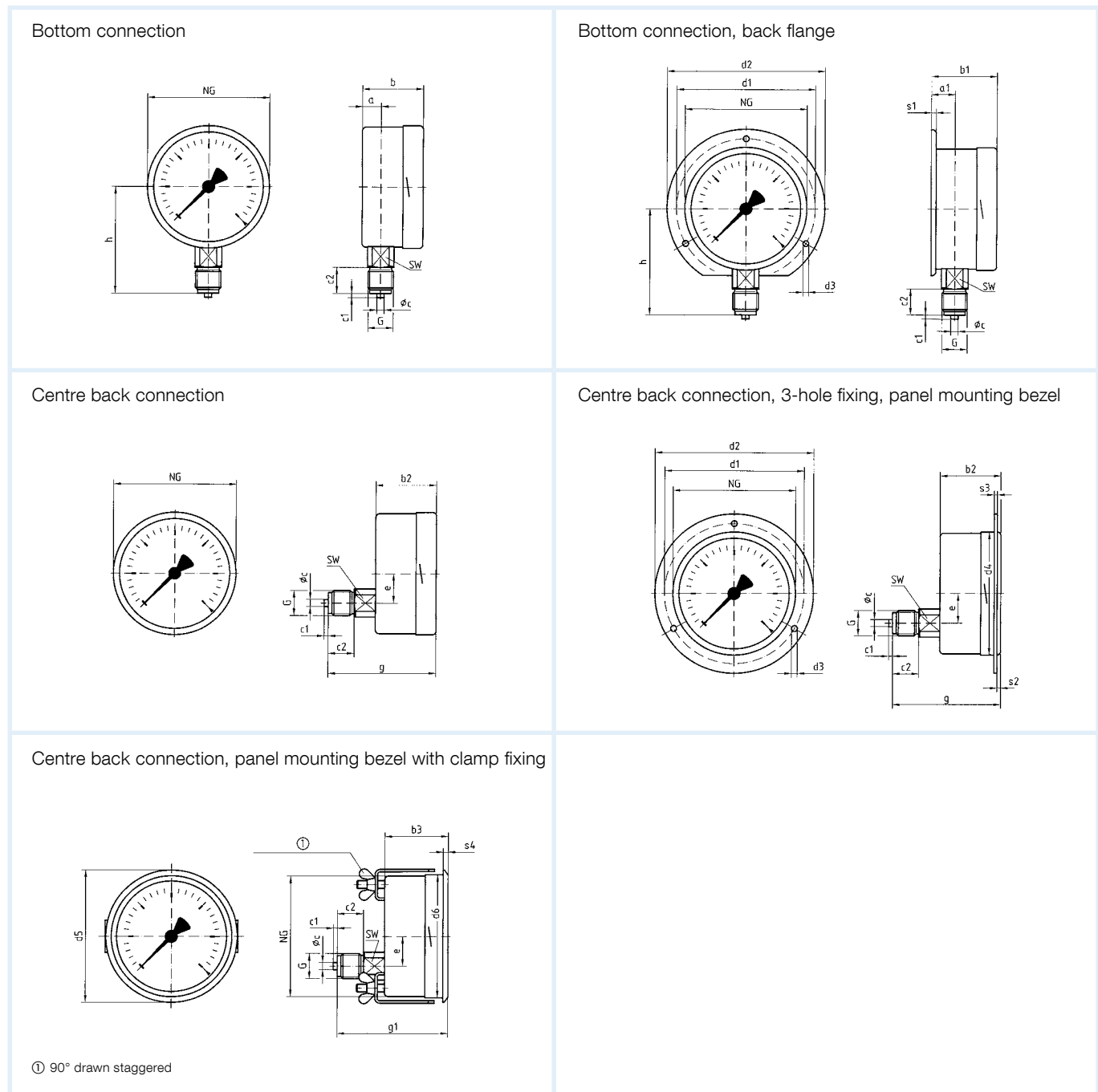

Dimensions (mm)

Nominal size (NG)	a	a1	b	b1	b2	b3	Øc	c1	c2	d1*	d2	d3*	d4	d5	d6	e	G	g	g1	h	s1
100	15.6	19.1	49	52.5	49	49	6	3	20	116	132	4.8	104	107	101	26.5	G½B	81	81	86	5.5
160	17.5	20.5	50	53	50	52	6	3	20	178	196	5.8	164	167	161	26.5	G½B	82	84	116	6
250	16	-	57	59	-	-	6	3	20	270	285	5.8	-	-	-	-	G½B	-	-	165	2
Nominal size (NG)	s2	s3	s4	SW																	
100	4	2	4	22																	
160	4	2	4.5	22																	
250	-	-	-	22																	

* Dimensions for NG 100 according to DIN 16064.

Bourdon tube pressure gauges for industrial applications

EN 837-1

DG: M, PG: 2

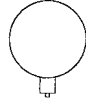
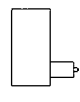
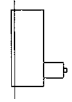
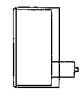
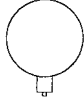
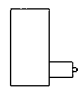
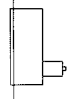
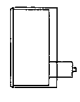
Type	RF100 I, D401	RF100 I, D411	RF100 I, D431	RF100 I, D451	RF160 I, D401	RF160 I, D411	RF160 I, D431	RF160 I, D451
Version								
Housing Ø	100	100	100	100	160	160	160	160
Housing	Stainless steel 304 with bayonet bezel, instrument glass window							
Measuring element	Bourdon tube, copper alloy (> 60 bar stainless steel 316 Ti/316 L)							
Accuracy class	1.0	1.0	1.0	1.0	1.0	1.0	1.0	1.0
Connection	G½B	G½B	G½B	G½B	G½B	G½B	G½B	G½B
			3-hole fixing, panel mounting bezel 304 polished	Panel mounting bezel, 304, polished, with clamp fixing			3-hole fixing, panel mounting bezel 304 polished	Panel mounting bezel, 304, polished, with clamp fixing
Range (bar)	Part no.	Part no.	Part no.	Part no.	Part no.	Part no.	Part no.	Part no.
Price €								
-1/0	85301401	85301411	85301431	85301451	85351401	85351411	85351431	85351451
-1/+0.6	85302401	85302411	85302431	85302451	85352401	85352411	85352431	85352451
-1/+1.5	85303401	85303411	85303431	85303451	85353401	85353411	85353431	85353451
-1/+3	85304401	85304411	85304431	85304451	85354401	85354411	85354431	85354451
-1/+5	85305401	85305411	85305431	85305451	85355401	85355411	85355431	85355451
-1/+9	85306401	85306411	85306431	85306451	85356401	85356411	85356431	85356451
-1/+15	85307401	85307411	85307431	85307451	85357401	85357411	85357431	85357451
Price €								
0/0.6	85309401	85309411	85309431	85309451	85359401	85359411	85359431	85359451
0/1	85310401	85310411	85310431	85310451	85360401	85360411	85360431	85360451
0/1.6	85311401	85311411	85311431	85311451	85361401	85361411	85361431	85361451
0/2.5	85312401	85312411	85312431	85312451	85362401	85362411	85362431	85362451
0/4	85313401	85313411	85313431	85313451	85363401	85363411	85363431	85363451
0/6	85314401	85314411	85314431	85314451	85364401	85364411	85364431	85364451
0/10	85315401	85315411	85315431	85315451	85365401	85365411	85365431	85365451
0/16	85316401	85316411	85316431	85316451	85366401	85366411	85366431	85366451
0/25	85317401	85317411	85317431	85317451	85367401	85367411	85367431	85367451
0/40	85318401	85318411	85318431	85318451	85368401	85368411	85368431	85368451
Price €								
0/60	85319401	85319411	85319431	85319451	85369401	85369411	85369431	85369451
0/100	85320401	85320411	85320431	85320451	85370401	85370411	85370431	85370451
0/160	85321401	85321411	85321431	85321451	85371401	85371411	85371431	85371451
0/250	85322401	85322411	85322431	85322451	85372401	85372411	85372431	85372451
0/400	85323401	85323411	85323431	85323451	85373401	85373411	85373431	85373451
Price €								
0/600	85324401	85324411	85324431	85324451	85374401	85374411	85374431	85374451
0/1000	85325401	85325411	85325431	85325451	85375401	85375411	85375431	85375451
Extra charge €								
Nominal size 250	---	---	---	---		---	---	---

Minimum order quantity for non-stock items = 10 pieces.

Blue part no. = in-stock items

Standard Bourdon tube pressure gauges for differential pressure



- Indication of plus pressure, minus pressure and differential pressure
- Excellent price/performance ratio
- Two independent Bourdon tube systems
- Housing and wetted parts also available in stainless steel (option)



Page 339

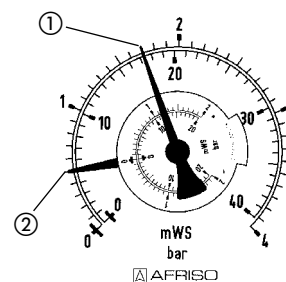

Reading example
 Δp (differential pressure)
 ① p1 (+ connection)
 ② p2 (- connection)

Application For differential pressure measurement of gaseous and liquid media which are not highly viscous, do not crystallize and do not attack copper alloys. Specially suitable for heating systems (supply and return pipes). ! For measuring gas or vapour, observe the table "Selection Criteria as per EN 837-2" (see appendix)!

Technical specifications

Type
D 2

Nominal size
100

Function
The pressures are measured in two independent Bourdon tube systems ("plus" pressure = high pressure, "minus" pressure = low pressure). The pressure is indicated by means of a dial and a pointer. The differential pressure scale covers 50 % of the range of the "plus" pressure and 50 % of the range of the "minus" pressure. The black pointer ("plus" connection) and the red pointer ("minus" connection) at the differential pressure gauge scale allow you to read the pressures in both systems on the fixed scale.

Accuracy class (EN 837-1/6)
1.6

Ranges (EN 837-1/5)
0/0.6 to 0/60 bar

Application area
The maximum pressure in the system must not exceed the full scale value. For good readability, the differential pressure to be measured should not be less than approx. 20 % of the full scale value.

Operating temperature range
 Medium: $T_{max} = +60\text{ }^{\circ}\text{C}$
 Ambient: $T_{min} = -20\text{ }^{\circ}\text{C}$
 $T_{max} = +60\text{ }^{\circ}\text{C}$

Temperature performance
Indication error when the temperature of the measuring system deviates from the normal temperature of 20 °C:
 rising temperature approx. $\pm 0.4\text{ } \%/10\text{ K}$
 falling temperature approx. $\pm 0.4\text{ } \%/10\text{ K}$
 of full scale value

Degree of protection
IP 32 (EN 60529)

Connection

Brass, bottom; parallel in line
 2 x G1½B – spanner size SW 22 (EN 837-1/7.3)
 Optional: Wetted parts stainless steel

Measuring element

Bourdon tube, "C" type tube, copper alloy

Movement

Brass

Dial

Aluminium, white
 Dial marking black (bar/mWC)

Pointer/dial

Aluminium

Housing

Sheet steel, black

Push on bezel

Sheet steel, black

Window

Instrument glass

DG: M, PG: 2	Part no.	Prices €
RF 100 Dif D 201, 0/1 bar	85610201	
RF 100 Dif D 201, 0/1.6 bar	85611201	
RF 100 Dif D 201, 0/2.5 bar	85612201	
RF 100 Dif D 201, 0/4 bar	85613201	
RF 100 Dif D 201, 0/6 bar	85614201	
RF 100 Dif D 201, 0/10 bar	85615201	
RF 100 Dif D 201, 0/16 bar	85616201	

i

See the catalogue
**INDUSTRIAL
 TECHNOLOGY** for
 other versions.

Standard capsule pressure gauges



EN 837-3



- **Housing:** Sheet steel or stainless steel version
- **With zero correction**
- **Ideal for low pressure ranges**
- **GOSSTANDART-certified**

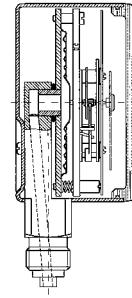

Application For gaseous, dry media which do not attack copper alloys.
! For measuring gas or vapour, observe the table "Selection Criteria as per EN 837-2" (see appendix)!

Technical specifications

Types

D2 / D3

Nominal size

100

Accuracy class (EN 837-3/6)

1.6

Ranges (EN 837-3/5)

0/25 to 0/1000 mbar and all corresponding vacuum and compound ranges with overpressure protection

Application area

Static load: full scale value
Dynamic load: 0.9 x full scale value
Overload safety: 1.3 x full scale value

Operating temperature range

Medium: $T_{max} = +60\text{ °C}$
Ambient: $T_{min} = -20\text{ °C}$
 $T_{max} = +60\text{ °C}$

Temperature performance

Indication error when the temperature of the measuring system deviates from the normal temperature of 20 °C:
rising temperature approx.
 $\pm 0.6\text{ \%}/10\text{ K}$
falling temperature approx.
 $\pm 0.6\text{ \%}/10\text{ K}$
of full scale value

Degree of protection

IP 44 (EN 60529)

Connection

Brass, bottom
G $\frac{1}{2}$ B – spanner size SW 22
(EN 837-3/7.3)

Measuring element

Capsule element, CuBe alloy

Movement

Brass

Zero correction

From the front

Seal

NBR (Perbunan)

Dial

Aluminium, white
Dial marking black

Pointer

Aluminium, black

Housing

D 2 – black, sheet steel
D 3 – stainless steel 304

Window

Clip-in plastic

11

DG: M, PG: 2	Housing	Part no.	Prices €
KP100 D201, 0/25 mbar	Sheet steel	35116201	
KP100 D201, 0/40 mbar	Sheet steel	35117201	
KP100 D201, 0/60 mbar	Sheet steel	35118201	
KP100 D201, 0/100 mbar	Sheet steel	35119201	
KP100 D201, 0/160 mbar	Sheet steel	35120201	
KP100 D201, 0/250 mbar	Sheet steel	35121201	
KP100 D201, 0/400 mbar	Sheet steel	35122201	
KP100 D201, 0/600 mbar	Sheet steel	35123201	
KP100 D201, 0/1000 mbar	Sheet steel	35124201	
KP100 D301, 0/25 mbar	Stainless steel	35116301	
KP100 D301, 0/40 mbar	Stainless steel	35117301	
KP100 D301, 0/60 mbar	Stainless steel	35118301	
KP100 D301, 0/100 mbar	Stainless steel	35119301	
KP100 D301, 0/160 mbar	Stainless steel	35120301	
KP100 D301, 0/250 mbar	Stainless steel	35121301	
KP100 D301, 0/400 mbar	Stainless steel	35122301	
KP100 D301, 0/600 mbar	Stainless steel	35123301	



See the catalogue
INDUSTRIAL
TECHNOLOGY for
other versions.

Standard capsule pressure gauges



EN 837-3



- **Housing:** Stainless steel version with bayonet bezel
- **With zero correction**
- **Optional overpressure and/or underpressure safety 10 x FSD**
- **Extremely low measuring ranges from 0/6 mbar**
- **GOSSTANDART-certified**

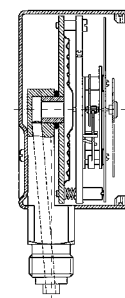

Application For gaseous, dry media which do not attack copper alloys.
! For measuring gas or vapour, observe the table "Selection Criteria as per EN 837-2" (see appendix)!

Technical specifications

Type

D 4

Nominal size

100

Accuracy class (EN 837-3/6)

1.6

Ranges (EN 837-3/5)

0/25 to 0/1000 mbar and all corresponding vacuum and compound ranges with overpressure protection

Application area

Static load: full scale value

Dynamic load: 0.9 x full scale value

Overload safety: 1.3 x full scale value

Operating temperature range

Medium: $T_{max} = +60\text{ °C}$

Ambient: $T_{min} = -20\text{ °C}$

$T_{max} = +60\text{ °C}$

Temperature performance

Indication error when the temperature of the measuring system deviates from the normal temperature of +20 °C:

rising temperature approx. $\pm 0.6\%$ /10 K

falling temperature approx. $\pm 0.6\%$ /10 K

of full scale value

Degree of protection

IP 54 (EN 60529)

Connection

Brass, bottom

G $\frac{1}{2}$ B – spanner size SW 22 (EN 837-3/7.3)

Measuring element

Capsule element, CuBe alloy

Movement

Brass

Zero correction

From the front

Seal

NBR (Perbunan)

Dial

Aluminium, white

Dial marking black

Pointer

Aluminium, black

Housing

Stainless steel 304

Bayonet type bezel

Stainless steel 304

Window

Instrument glass

11

i

See the catalogue INDUSTRIAL TECHNOLOGY for other versions.

DG: M, PG: 2	Housing	Part no.	Prices €
KP100 D401, 0/40 mbar	Stainless steel	35117401	
KP100 D401, 0/60 mbar	Stainless steel	35118401	
KP100 D401, 0/100 mbar	Stainless steel	35119401	
KP100 D401, 0/160 mbar	Stainless steel	35120401	
KP100 D401, 0/250 mbar	Stainless steel	35121401	
KP100 D401, 0/400 mbar	Stainless steel	35122401	

Shut-off cocks and valves for pressure gauges



Shut-off cocks for pressure gauges

Application Shut-off element between pipe and pressure gauge. Shut-off cocks with test port allow you to connect both pressure gauges and testers to the pipe. Suitable for liquids, gases and vapour.

Technical specifications

Version
DIN 16261 to 16263
(or based on DIN)

Operating temperature range
Medium: -10/+50 °C

Connection and nominal pressure
See price list

Housing and tap
Brass bare metal surface or stainless steel bare metal surface.
The tap contains two holes which are arranged in the shape of a T. The function depends on the tap position:

1. Vent pressure gauge
2. Apply pressure to pressure gauge
3. Blow out measuring line
4. Apply pressure to tester

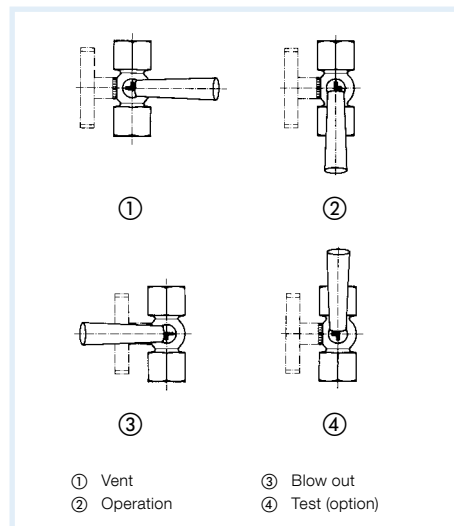

Pressure gauges shut-off valves

Shut-off or reducing element between pipe and pressure gauge. Stop valves with test port allow you to connect both pressure gauges and testers to the measuring line. Suitable for liquids, gases and vapour.

Version
DIN 16270 without test port
DIN 16271 with test port, male M20 x 1.5
DIN 16272 with test port which can be closed separately, male, see 16271
Type A female/female x male connection
Type B loose female coupling x male connection and shaft for instrument bracket

Operating temperature range
Brass -10/+120 °C
Steel 1.0460 -10/+120 °C
Stainless steel 316 Ti -20/+200 °C

Connection and nominal pressure
See price list

Materials

Parts	Brass	Steel	Stainless steel
Housing	Brass	1.0460	316 Ti
Valve spindle	Brass	430 F	316 Ti
Valve cone	Brass	430 F	316 Ti
Packing	PTFE	PTFE	PTFE
Cap	Brass	Steel	Stainless steel
Union nut	Brass	Steel	Stainless steel
Female/female connection	Brass	Steel	Stainless steel
Loose female coupling	Brass	Steel	Stainless steel
Vent screw	316 Ti	316 Ti	316 Ti
Hand wheel	Plastic	Plastic	Plastic

Accessories for pressure gauges

DG: H

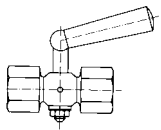
Pressure gauge shut-off cock female x female						
	Connection	Nominal pressure	Material	PG	Part no.	Price €
	G $\frac{1}{4}$	PN 6	Brass	2	63001	
	G $\frac{3}{8}$	PN 16	Brass	2	63002	
	G $\frac{1}{2}$	PN 16	Brass	2	63003	
With round test flange 40 x 5	G $\frac{1}{2}$	PN 16	Brass	2	63004	
With test flange 60 x 25 x 10	G $\frac{1}{2}$	PN 16	Brass	2	63005	
With sealing gland	G $\frac{1}{2}$	PN 16	Brass	2	63006	

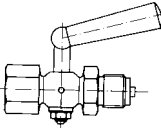
Pressure gauge shut-off cock female x male						
	Connection	Nominal pressure	Material	PG	Part no.	Price €
	G $\frac{1}{4}$	PN 6	Brass	2	63011	
	G $\frac{3}{8}$	PN 16	Brass	2	63012	
	G $\frac{1}{2}$	PN 16	Brass	2	63013	
With round test flange 40 x 5	G $\frac{1}{2}$	PN 16	Brass	2	63009	
With test flange 60 x 25 x 10	G $\frac{1}{2}$	PN 16	Brass	2	63010	

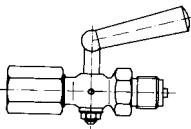
Pressure gauge shut-off cock female/female x male							
	Connection	Nominal pressure	Material	PG	Part no.	Price €	
	G $\frac{1}{4}$	PN 6	Brass	2	63014		
	G $\frac{1}{2}$	PN 16	Brass	2	63027		
	G $\frac{1}{2}$	PN 16	1.4571	3	63090		
	With test flange 60 x 25 x 10	G $\frac{1}{2}$	PN 16	Brass	2	63028	
	With test flange 60 x 25 x 10	G $\frac{1}{2}$	PN 16	1.4571	3	63091	
With male test connection M20 x 1.5	G $\frac{1}{2}$	PN 16	Brass	2	63015		
With male test connection M20 x 1.5	G $\frac{1}{2}$	PN 16	1.4571	3	63016		

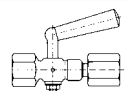
Pressure gauge shut-off cock loose female x female						
	Connection	Nominal pressure	Material	PG	Part no.	Price €
	G $\frac{1}{2}$	PN 16	Brass	2	63017	
	G $\frac{1}{2}$	PN 16	Brass	2	63018	

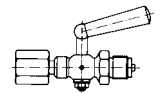
Pressure gauge shut-off cock loose female x male						
	Connection	Nominal pressure	Material	PG	Part no.	Price €
	G $\frac{1}{2}$	PN 16	Brass	2	63107	
	G $\frac{1}{2}$	PN 16	Brass	2	63024	

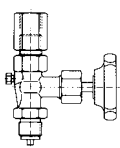
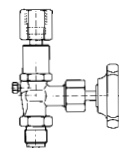
Pressure gauge shut-off valve DIN 16270									
Type A – female/female x male connection					Type B – loose female coupling x male connection and shaft for instrument bracket				
Type A	Type B	Connection	Nominal pressure	Material	PG	Type A	Price €	Type B	Price €
						Part no.		Part no.	
		G $\frac{1}{4}$	PN 125	Brass	2	63094		---	---
		G $\frac{1}{2}$	PN 250	Brass	2	63092		63046	
		G $\frac{1}{2}$	PN 400	Steel	3	63040		63047	
		G $\frac{1}{2}$	PN 400	1.4571	3	63093		63048	
Test connection male M20 x 1.5 DIN 16271		G $\frac{1}{2}$	PN 250	Brass	2	63041		63049	
		G $\frac{1}{2}$	PN 400	Steel	3	63042		63108	
		G $\frac{1}{2}$	PN 400	1.4571	3	63044		63109	
Extra charge oil-free and grease-free*						63045	On request	63110	On request
Extra charge DVGW-tested								---	

* Only for brass and stainless steel.

Overpressure safety device, Pressure gauge push-button stop cock

Overpressure safety device

Application Adjustable overpressure safety device used to protect the system against peak pressures exceeding the range of the pressure gauge. At measuring points which are subject to great pressure variations, you can install different pressure gauges with different ranges in order to precisely measure even the lower pressures. The overpressure safety devices are adjusted according to the maximum permissible pressure ratings of the various pressure gauges installed.

Technical specifications

Function

When the set pressure is reached, a piston valve shuts off the port to the pressure gauge. After the pressure has dropped to a value of approx. 25 % below the closing pressure, the valve opens again.

Operating temperature range

Max. +80 °C

Overpressure safety

Brass: 600 bar

Stainless steel: 1,000 bar

Max. vacuum range up to -1 bar, no adjustment function

Connection

G $\frac{1}{2}$ female/female connection x male connection

Materials overpressure safety device

Parts	Brass	Stainless steel
Housing	Brass	316 Ti
Piston	316 Ti	316 Ti
Female/female connection	Steel	303
Diaphragm	FKM	FKM
O ring	FKM	FKM

Pressure gauge push-button stop cock

Application Shut-off element between measuring line and pressure gauge. Normally, the push-button stop cock is closed. In this state, there is no pressure applied to the pressure gauge. Push the button to apply pressure to the pressure gauge and to display the operating pressure. Suitable for gases as per DVGW G260 and SVGW.

Technical specifications

Test

DVGW- and SVGW-tested, with EC Type Examination Certificate, product ID number CE-0085AQ0985

Operating temperature range

Medium: 0/70 °C

Ambient: -20/+60 °C

Connection

2 x female thread

Rp $\frac{1}{2}$, EN 10226

Rp $\frac{1}{4}$, EN 10226

$\frac{1}{2}$ NPT (without test)

$\frac{1}{4}$ NPT (without test)

Nominal pressure

5 bar (MOP 5)

Housing

Brass, nickel-plated



Overpressure safety device

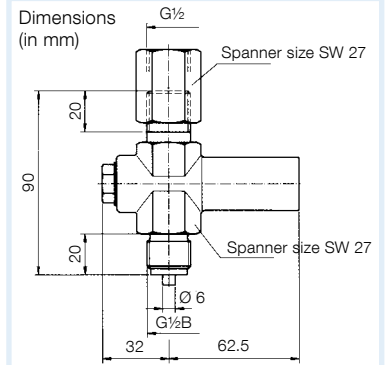

Pressure gauge push-button stop cock

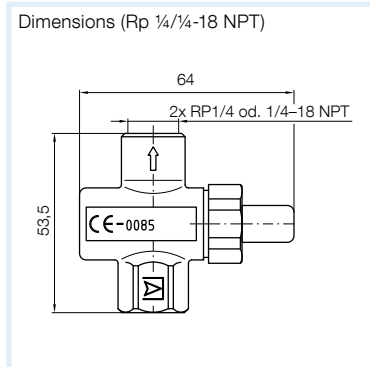
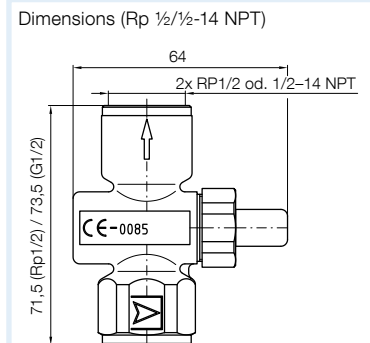

Accessories for pressure gauges

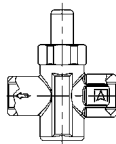

DG: H

Pressure gauge push-button stop cock female x female – DVGW- and SVGW-tested/CE-0085AQ0985						
	Connection	Nominal pressure	Material	PG	Part no.	Price €
	Rp 1/2, EN 10226	MOP 5	Brass, nickel-plated	2	63031	
	Rp 1/4, EN 10226	MOP 5	Brass, nickel-plated	2	63191	
	1/4-18 NPT*	MOP 5	Brass, nickel-plated	2	63193	
	1/2-14 NPT*	MOP 5	Brass, nickel-plated	2	63235	

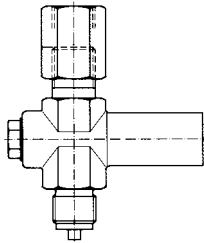

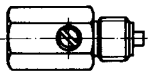
* Without DVGW and SVGW approval.

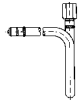

Overpressure safety device G1/2 female/female connection x male – adjustable, vacuum-tight									
	Adjustment range in bar	Material	PG	Part no.	Price €	Material	PG	Part no.	Price €
	0.4–2.5	Brass	2	63131		316 Ti	3	63139	
	2–6	Brass	2	63132		316 Ti	3	63140	
	5–25	Brass	2	63133		316 Ti	3	63141	
	20–60	Brass	2	63134		316 Ti	3	63142	
	50–250	Brass	2	63135		316 Ti	3	63143	
	240–400	Brass	2	63136		316 Ti	3	63144	
Extra charge oil-free and grease-free			-	63137	On request		-	63145	On request
Extra charge DVGW-tested			-	63138			-	63146	

Damping device (pressure surge protection) female x male – adjustable						
	Connection	Nominal pressure	Material	PG	Part no.	Price €
	G1/2	PN 400	Brass	2	63074	
	G1/2	PN 400	316 Ti	3	63076	

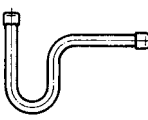
Siphon DIN 16282 – outlet female/female connection G1/2								
U shape		Shape	Inlet	Material	Nominal pressure	PG	Part no.	Price €
		A*	G1/2B	Steel	PN 100	3	63147	
Circular shape		B	Without thread, welded end 20 x 2.6 mm	Steel	PN 100	3	63148	
		A*	G1/2B	316 Ti	PN 100	3	63149	
		C*	G1/2B	Steel	PN 100	3	63150	
		D	Without thread, welded end 20 x 2.6 mm	Steel	PN 100	3	63151	
		C*	G1/2B	316 Ti	PN 100	3	63152	

* Types A and C are no longer provided for in the new DIN edition.

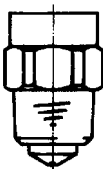
Siphon – standard – inlet G1/2								
U shape	Circular shape	Shape	Outlet	Material	Nominal pressure	PG	Part no.	Price €
		U-	G1/2B	Steel	PN 25	3	63085	
		U-	Female/female connection G1/2B	Steel	PN 25	3	63153	
		Circular	G1/2B	Steel	PN 25	3	63081	
		Circular	Female/female connection G1/2B	Steel	PN 25	3	63154	

Mounting valve with self-sealing coating – automatically closes when the pressure gauge is replaced								
	Female connection	Male connection	Material	PG			Part no.	Price €
	G1/4	G1/4	Brass	2	1	–	77907	
	G1/4	G3/8	Brass	2	1	–	77908	
	R3/8	G3/8	Brass	2	25	250	77917	
	G1/4	G1/2	Brass	2	1	–	77914	
	G3/8	G1/2	Brass	2	25	250	77918	

Accessories for pressure gauges

DG: H

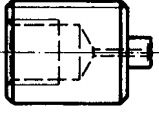
Connection nipple – self-sealing						
	Female connection	Male connection	Material	PG	Part no.	Price €
	G $\frac{1}{8}$	G $\frac{1}{4}$	Brass	2	63067	
	G $\frac{1}{4}$	G $\frac{3}{8}$	Brass	2	63068	
	G $\frac{1}{4}$	G $\frac{1}{2}$	Brass	2	63069	
	G $\frac{3}{8}$	G $\frac{1}{2}$	Brass	2	63065	

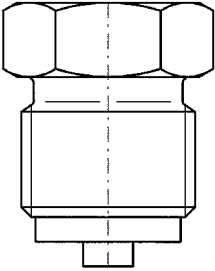
Reducers and adapters						
	Female connection	Male connection	Material	PG	Part no.	Price €
	G $\frac{1}{8}$	G $\frac{1}{4}$	Brass	2	63050	
	G $\frac{1}{4}$	G $\frac{1}{8}$	Brass	2	63052	
	G $\frac{1}{4}$	G $\frac{3}{8}$	Brass	2	63053	
	G $\frac{1}{4}$	G $\frac{1}{2}$	Brass	2	63054	
	G $\frac{1}{4}$	G $\frac{1}{2}$	316 Ti	3	63051	
	G $\frac{3}{8}$	G $\frac{1}{4}$	Brass	2	63056	
	G $\frac{3}{8}$	G $\frac{1}{2}$	Brass	2	63057	
	G $\frac{1}{2}$	G $\frac{1}{4}$	Brass	2	63058	
	G $\frac{1}{2}$	G $\frac{3}{8}$	Brass	2	63059	
G $\frac{1}{2}$	M 20 x 1.5	Brass	2	63155		

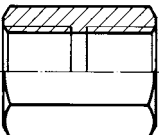
	Female connection	Female connection	Material	PG	Part no.	Price €
	G $\frac{1}{4}$	G $\frac{1}{4}$	Brass	2	63159	

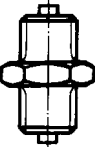
	Male connection	Male connection	Material	PG	Part no.	Price €
	G $\frac{1}{2}$	G $\frac{1}{2}$	Brass	2	63164	
	G $\frac{1}{2}$	G $\frac{1}{2}$	316 Ti	3	63165	

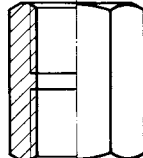
Female/female connection DIN 16283						
	Female connection	Female connection	Material	PG	Part no.	Price €
	G $\frac{1}{2}$ left	G $\frac{1}{2}$	Brass	2	63104	
	G $\frac{1}{2}$ left	G $\frac{1}{2}$	Steel	3	63105	
	G $\frac{1}{2}$ left	G $\frac{1}{2}$	316 Ti	3	63106	

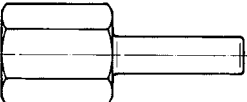
Union nut + nipple DIN 16284						
	Female connection	Male connection	Material	PG	Part no.	Price €
	G $\frac{1}{4}$	6 mm	Brass	2	63072	
	G $\frac{1}{2}$	12 mm	Brass	2	63084	
	G $\frac{1}{2}$	12 mm	316 Ti	3	63070	

CATALOGUE INDUSTRIAL TECHNOLOGY

Pressure measuring instrument for industrial applications and process engineering



Standard pressure gauges

- + For pneumatic and mechanical engineering applications
- + Highly impact-resistant plastic housing or robust steel or stainless steel housing
- + Window with adjustable reference pointer
- + Options: Special scales, connections for different processes, mounting flanges, etc.

Nominal sizes
40 – 50 – 63 – 80 – 100

Accuracy class
1.6



From page 21



Pressure gauges for industrial applications

- + For machine and plant engineering
- + Robust steel or stainless steel housing
- + Optionally with electrical contact

Nominal sizes
100

Accuracy class
1.0



From page 32

i

This and many other products can be found in the catalogue INDUSTRIAL TECHNOLOGY.



Glycerine filled pressure gauges

- + Can be used in case of heavy vibrations and high, dynamic pressure loads
- + Less wear and corrosion protection of the measuring system
- + No steaming up of the inside of the window in case of outdoor applications

Nominal sizes
40 – 50 – 63 – 80 – 100 – 160

Accuracy class
1.0 or 1.6



From page 38



Pressure gauges for chemical applications

- + For chemical and process engineering applications
- + Measuring system fully welded to housing
- + For temperatures of the medium of up to 150 °C

Nominal sizes
50 – 63 – 100 – 160

Accuracy class
1.0 or 1.6



From page 55



Safety pressure gauges

- + Safety pressure gauge S3 as per EN 837-1/9.7.2
- + Measuring system fully welded to housing

Nominal sizes
63 – 100 – 160

Accuracy class
1.0 or 1.6

 **From page 69**



Pressure gauges for refrigeration engineering

- + Can be used in case of heavy vibrations and high, dynamic pressure loads
- + Various refrigerants measurable with multiple scales

Nominal sizes
60 – 80 – 100

Accuracy class
1.0 or 1.6

 **From page 89**



Precision pressure gauges

- + High measuring accuracy
- + Suitable as measuring equipment as per QA requirements

Nominal sizes
160 – 250

Accuracy class
0.6

 **From page 81**



Pressure gauges with electrical contacts

- + Up to 3 contacts possible
- + Either magnetic spring contact, electronic contact or inductive contact

Nominal sizes
63 – 100 – 160

Accuracy class
1.0 or 1.6

 **From page 102**



Magnetic piston pressure gauges

- + For differential pressure measurement at high pressure, e.g. monitoring of filters, pumps, pipes or cooling circuits
- + High overload protection: Max. static pressure PN 100 to 400

Nominal sizes
63 – 80 – 100

 **From page 134**



Pressure gauges for differential pressure

- + Measurement of extremely small differential pressures
- + Direct indication of the differential pressure
- + High overload protection

Nominal sizes
63 – 100 – 160

Accuracy class
1.6 or 2.5



From page 145



Pressure transducer DMU 02 Vario

- + Connection technology with numerous versions for applications in many industries
- + Extremely resistant to shock, pulsation and vibration
- + Best dynamic pressure resistance at high load changes

Measuring ranges
-1/0 to -1/+24 bar
0/1 to 0/1,000 bar



From page 206



Pressure transducer DMU 01 K

- + Compact version for OEMs
- + Proven ceramic technology
- + No mechanical ageing of the measuring cell

Measuring ranges
0/1.6 to 0/250 bar



From page 199



Digital pressure gauge DIM 20

- + High flexibility due to selectable units
- + Min./max. memory
- + Display can be rotated by 330°

Measuring ranges
-1/0 bar, 0/2.5 bar
to 0/700 bar



From page 248



Bimetal thermometers



Thermometers with capillary tube

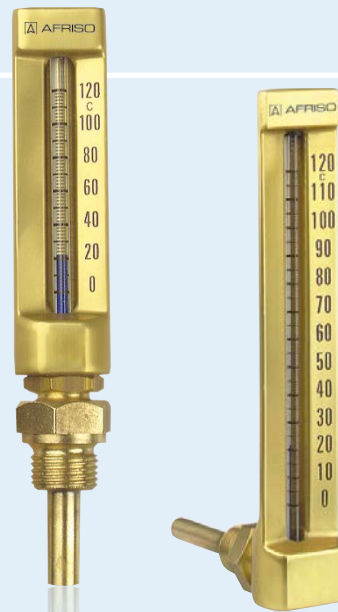

Industrial thermometers



Resistance thermometers

CHAPTER 12

Temperature measuring instruments and controllers

OVERVIEW

Mechanical temperature measuring instruments at a glance	350
Electronic temperature measuring instruments at a glance	352
Thermometers with capillary tube	354

HEATING/PLUMBING

Thermometers THK with capillary tube	355
Combined thermometer/pressure gauges THMK with capillary	357
Combined thermometer/pressure gauges TM /thermometer-hydrometer TH	361
Bimetal thermometers BiTh for heating/plumbing applications	364
Bimetal standard thermometers, surface mount thermometers ATh , flue gas thermometers RT , flue gas temperature controller RTC	367
Temperature control thermostats TRT with capillary tube	384
Safety temperature cut outs STB with capillary	386
Surface mounting thermostats with housing GAT	390
Immersion thermostats with housing GTT	392
Thermostats with housing GTK with capillary tube	394
Room thermostats with housing GRT	396
Twin thermostats with housing GDT	398
Resistance thermometers WTh 20–23	401

PLANT/VENTILATION ENGINEERING

Bimetal thermometers for industrial applications, bimetal air duct thermometers	372
Bimetal stainless steel thermometers	377
Connection types for bimetal thermometers	381
Industrial thermometers VMTh	382

ACCESSORIES

Pockets for thermometers and thermostats with capillary tube	389
--------------------------------------------------------------	-----

Mechanical temperature measuring instruments at a glance



		Thermometers with capillary	Bimetal thermometers	Bimetal standard thermometers	Surface mount thermometers	Flue gas thermometers
Application areas	Heating and plumbing	•	•	•	•	•
	Mechanical and plant engineering					
	Process engineering					
	Chemical applications					
	Food industry					
	Hygienic processes					
	Corrosive media					
Ranges	NG 40	•	•			
	NG 50		•	•		
	NG 52	•				
	NG 63		•	•	•	
	NG 80		•	•	•	•
	NG 100		•	•		
	NG 160			•		
	Profile housing	•				
	-40/+40 °C	•				
	-30/+50 °C					
-20/+60 °C		•	•			
-20/+40 °C				•		
0/60 °C		•	•	•		
0/120 °C	•	•	•	•		
0/160 °C			•			
0/200 °C						
≥ 0/300 °C					•	
Accuracy	Class 1 (EN 13190)					
	Class 2 (EN 13190)		•	•	•	•
	DIN 16195					
Housing	Plastic	•	•		•	
	Sheet steel galvanised			•	•	•
	Aluminium, eloxed					
	Stainless steel 304					
Connection	Stem		•	•		•
	Plug-on		•			
	Mounting flange					
	Flange					
	Fastening spring/clip				•	
Options	Magnetic holder				•	
	Capillary tube	•				
	Other ranges	•		•	•	
	Other connection designs	•				
	Glycerine filling					
	Electrical contacts					
			Page 354	Page 364	Page 367	Page 367

i Technical specifications, application areas and suitability depend on the product version. See catalogue data sheet and/or operating instructions for options and details.

Electronic temperature measuring instruments at a glance



		Resistance thermometer WTh 20	Resistance thermometer WTh 21	Resistance thermometer WTh 22	Resistance thermometer WTh 23	Resistance thermometer WTh 24
Heating and plumbing	Application areas	•	•	•	•	
Air conditioning/ventilation		•	•	•	•	
Pipeline engineering				•	•	•
Mechanical and plant engineering					•	•
Appliance engineering						•
Chemical/process engineering applications						•
pharmaceutical applications/ biotechnology						
Food industry / hygienic processes						
Corrosive media						•
High temperatures						
High pressure loads						
Cable probe	Version	•				
Fixed thread					•	•
Screwed pipe connection						
Flange connection						
Clamp connection						
Varivent connection						
Weld-in thermometer						
Pt 100, class A	Sensor				•	•
Pt 100, class B		•	•	•	•	•
100 mm	Installation lengths			•	•	•
125 mm						
160 mm				•		•
≥ 250 mm				•		•
Housing plastic	Material		•	•		
Housing aluminium					•	•
Wetted parts 316 Ti		•	•	•	•	•
Wetted parts 316 L						
Cable (wire ferrules)	Electr. connection	•				
Cable gland			•	•	•	•
Connector						
Other designs	Options	•	•		•	
Other process connections				•	•	
Transmitter installation			•		•	•
		Page 401	Page 401	Page 402	Page 284	Page 284

i

Technical specifications, application areas and suitability depend on the product version. See catalogue data sheet and/or operating instructions for options and details.

Thermometers with capillary tube

For burners, boiler, hot water tanks and air conditioning/refrigeration systems, AFRISO offers different temperature and pressure measuring instruments with various housing versions and connection types. The portfolio covers pressure gauges and thermometers with plastic or copper capillaries as well as combination instruments such as combined thermometer/pressure gauges. We also provide OEM versions for your specific applications. Please enquire.

Application examples



12



i See page 322 for pressure gauge with capillary tube.

Thermometers THK with capillary tube



- Ideal for boilers and water heaters
- Corrosion-resistant, highly impact-resistant plastic housing
- Many customised versions available

Application Heating and plumbing, e.g. boilers, water heaters, hot water storage tanks.

Technical specifications

Nominal size
37 – 40 – 52 – 45 x 45

Range
0/120 °C

Accuracy/test point
50 °C = ±3 °C

Measuring principle
Liquid filling

Operating temperature range

Medium: Full scale value
Ambient: $T_{\max} = +70$ °C

Operating pressure

No pressure

Degree of protection

IP 32 (EN 60529)

Standard version

Connection
Back, with Cu capillary tube
Probe: Ø 6 x 30 mm, Cu
(see data sheet)

Dial
Plastic (ABS), white or black
Dial marking black

Pointer
Plastic, black or white

Housing

Plastic (ABS), white, black or grey
Highly impact-resistant and corrosion-resistant

Window

Clip-in plastic, transparent
RFK 52 with bezel

Capillary length

Cu capillary with PVC coating, R3, grey
L = 500, 1000, 1500, 2000 mm





- Options**
- Dial with customer logo
 - Various capillary lengths
 - Special colours for housing, dial, pointer

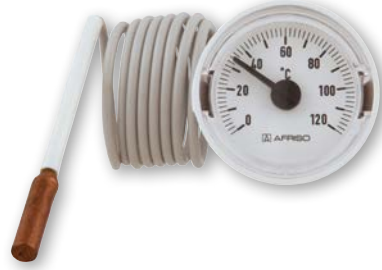
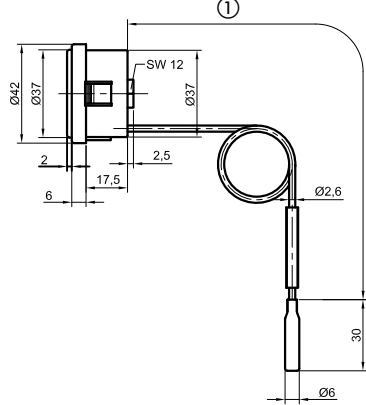
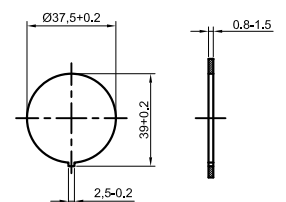
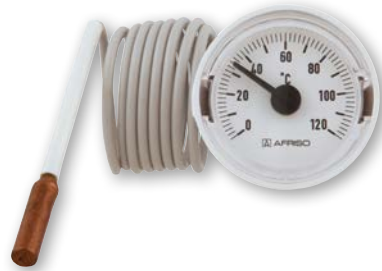
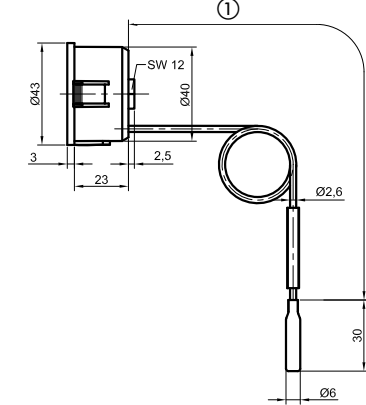
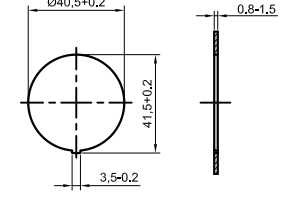

See page 359 for prices.

Thermometers THK with capillary tube

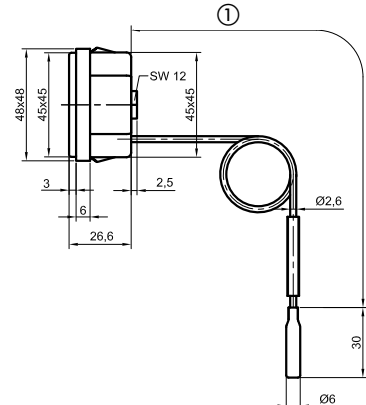
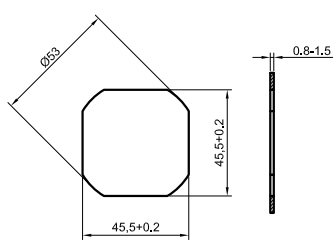
Dimensions (in mm)

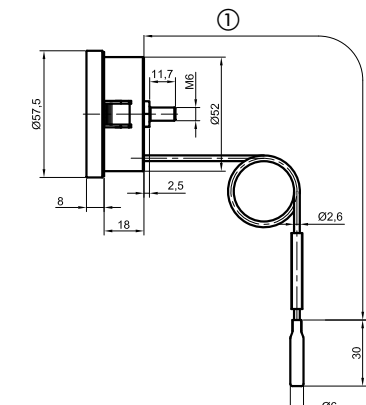
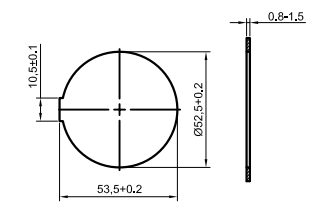
<p>Type THK 37</p> 		 <p>① Capillary length</p>
<p>Type THK 40</p> 		 <p>① Capillary length</p>
<p>Type THK 45</p> 		 <p>① Capillary length</p>
<p>Type THK 52</p> 		 <p>① Capillary length</p>

12

Combined thermometer/pressure gauges THMK with capillary tube

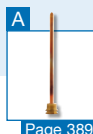

Page 369

- Ideal for boilers and hot water storage tanks
- Corrosion-resistant, highly impact-resistant plastic housing
- Many customised versions available

Application Heating, cooling and plumbing, e.g. boilers, hot water storage tanks.

Technical specifications

Nominal size

40 – 52

Ranges

0/120 °C – 0/4 bar

0/120 °C – 0/6 bar

0/120 °C – 0/10 bar

Accuracy/test point

For pressure: Cl. 4.0

For temperature: 0/120 °C: 50 °C = ±3 °C

Measuring principle

For pressure: Bourdon tube, copper alloy

For temperature: Liquid filling

Application area

For pressure:

Static load: $\frac{3}{4}$ x full scale valueDynamic load: $\frac{2}{3}$ x full scale value

Short-term: full scale value

For temperature: Full scale value

Operating temperature range

Medium: Full scale value

Ambient: $T_{\max} = +70$ °C

Operating pressure

No pressure

Degree of protection

IP 32 (EN 60529)

Standard version

Connection

Back, with Cu capillary tube

For pressure: Brass disk G $\frac{1}{4}$ BFor temperature: Probe \varnothing 6 x 30 mm, Cu
(see data sheet)

Dial

Plastic (ABS), white or black

Dial marking black

Pointer

Plastic, black

Housing

Plastic (ABS), white or grey

Highly impact-resistant and corrosion-resistant

Window

THMK 40 = Clip-in plastic, transparent

THMK 52 = Plastic, transparent with
reference pointer

Bezel

THMK 52 = Push-on bezel

Plastic (ABS), grey

Capillary length

Cu capillary with PVC coating, R3, grey

L = 500, 1000, 1500, 2000 mm

Options

- Dial with customer logo
- Various capillary lengths
- Special colours for housing, dial, pointer



See page 359 for prices.

Combined thermometer/pressure gauges THMK with capillary tube

Dimensions (in mm)

Type THMK 40

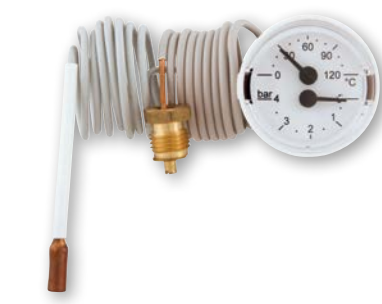
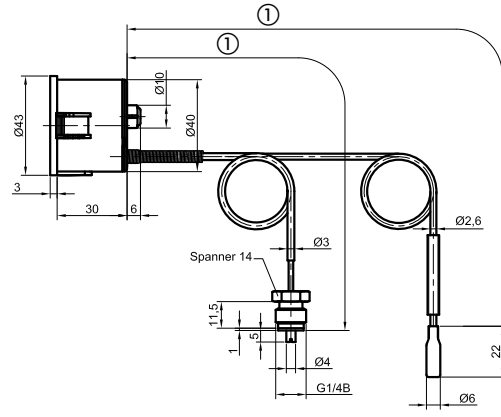
① Capillary length





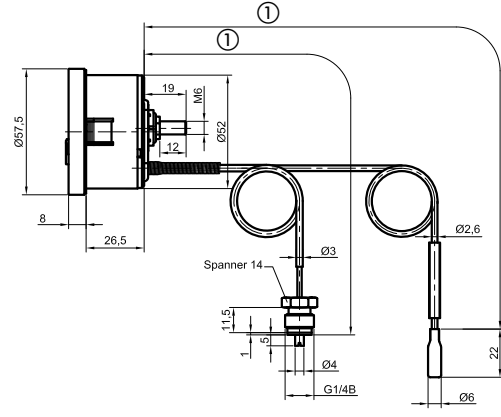

Type THMK 52

① Capillary length

Thermometers with capillary tube

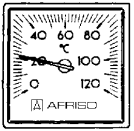
DG: G, PG: 2





Type	THK 37	THK 40	THK 45	THK 52	THMK 40	THMK 52
Version						
Housing Ø	37	40	45 x 45	52	40	52
Housing	Plastic (ABS), grey	Plastic (ABS), white	Plastic (ABS), black	Plastic (ABS), grey, with bezel, black	Plastic (ABS), white	Plastic (ABS), grey, with bezel, black
Pointer	Plastic, black		Plastic, white		Plastic, black	Plastic, white
Dial/scale	Dial white / scale black		Dial black / scale white		Dial white / scale black	Dial black / scale white
Packing unit**	50 pieces					
Range	0/120 °C	0/120 °C	0/120 °C	0/120 °C	0/120 °C - 0/4 bar	
Capillary length*	Price € Part no.	Price € Part no.	Price € Part no.	Price € Part no.	Price € Part no.	Price € Part no.
500 mm	67512105	67652105	67522105	67502105		67635105
1,000 mm	67512115	67652115	67522115	67502115		67635115
1,500 mm	67512125	67652125	67522125	67502125		67635125
2,000 mm	67512135	67652135	67522135	67502135		67635135
Range	---	---	---	---	0/120 °C - 0/6 bar	
Capillary length*	---	---	---	---	Price € Part no.	Price € Part no.
500 mm	---	---	---	---		
1,000 mm	---	---	---	---		
1,500 mm	---	---	---	---		67636125
2,000 mm	---	---	---	---		
Range	---	---	---	---	0/120 °C - 0/10 bar	
Capillary length*	---	---	---	---	---	Price € Part no.
500 mm	---	---	---	---	---	
1,000 mm	---	---	---	---	---	
1,500 mm	---	---	---	---	---	
2,000 mm	---	---	---	---	---	

* Other capillary lengths on request.

** Minimum order quantity for non-stock items = 100 pieces per delivery.

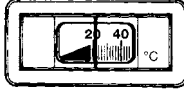
Thermometers THK with capillary tube

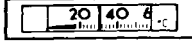
DG: G, PG: 2

Type	THK 58 S Cu	THK 58 Cu	THK 62 Cu	THK 62 Cu
Version				
Nominal size (W x H)	58 x 25 mm	25 x 58 mm	62 x 11 mm	62 x 11 mm
Housing	Plastic, black			
Dial/scale	Dial white / numbers black			
Mounting position	Horizontal	Vertical	Horizontal	Horizontal
Capillary	Cu capillary with PVC jacket (R3, grey), Cu probe Ø 6.5 x 30 mm		Cu capillary with PVC jacket (R3, grey), Cu probe Ø 6.5 x 25 mm	
Packing unit	100 pieces			
Range	0/120 °C	0/120 °C	0/120 °C	0/120 °C
Capillary length*	Price € Part no.**	Price € Part no.**	Price € Part no.**	Price € Part no.**
1,000 mm	67542115	67542115s	67562115	67582115
1,500 mm	67542125	67542125s	67562125	67582125
2,000 mm	67542135	67542135s	67562135	67582135
3,500 mm	67542155	---	---	---

* Other capillary lengths on request.

** Minimum order quantity for non-stock items = 300 pieces.

Combined thermometer/pressure gauges TM / thermo-hydrometers TH



- Pressure and temperature measurement with at a single measuring point
- With self-sealing connection thread for fast mounting
- Bottom connection or back connection
- With mounting valve for easy replacement without downtime



Bottom connection version

Application For liquid media which are not highly viscous, do not crystallise and do not attack copper alloys. For combined measurement of pressure and temperature, especially in heating systems and heating boilers.

Description The combined thermometer/pressure gauge / thermo-hydrometer consists of a Bourdon tube measuring system for pressure measurement and a bimetal measuring system for simultaneous temperature measurement. Both values are measured and displayed by a single gauge. A self-closing mounting valve enables easy replacement of the gauge without the necessity to drain the system. An optional M18 x 1 to G1/4 adapter is available if the combined thermometer/pressure gauge has to be mounted into an existing thermowell with M18 x 1 female thread.

Technical specifications

Type

D 1/D 2

Nominal size

63 – 80

Accuracy class

Pressure gauge/hydrometer: 2.5 (EN 837-1/6)

Application area

Pressure gauge/hydrometer:

Static load: $\frac{3}{4}$ x full scale value

Dynamic load: $\frac{2}{3}$ x full scale value

Short-term: full scale value

Thermometer: 20/120 °C

Ranges

Pressure gauge/hydrometer:

0/4 bar to 0/10 and 0/6 mWC to 0/60 mWC

Thermometer: 20/120 °C

Operating temperature range

Medium: $T_{max} = +120$ °C

Ambient: $T_{min} = -20$ °C

$T_{max} = +60$ °C

Temperature performance

Pressure gauge/hydrometer:

Indication error when the temperature of the measuring system deviates from the normal temperature of 20 °C:

rising temperature approx. ± 0.4 %/10 K

falling temperature approx. ± 0.4 %/10 K

of full scale value

Degree of protection

IP 32 (EN 60529)

Standard version

Connection

Brass, bottom or centre back G1/4B with mounting valve G1/4 to R1/2

Measuring element

Pressure: Bourdon tube, copper alloy

Temperature: bimetal element

Dial

Plastic, white

Dial marking black with circular arcs (red/blue)

Pointer

Pressure gauge/hydrometer: plastic, black

Thermometer: plastic, red

Housing

D1 – plastic (ABS), highly impact-resistant

D2 – sheet steel black

Window

Clip-in plastic with adjustable red mark

Options

- Adapter M 18 x 1 to G1/4
- Special scales
- Other process connections



See page 363 for prices.

Combined thermometer/pressure gauges / thermo-hydrometers TM

Housing types and dimensions (mm)

TM 63 ax

① PTFE sealing ring

TM 80 ax

① PTFE sealing ring

TM 63 ax with mounting valve

① Mounting valve
② Pipe thread

TM 80 ax with mounting valve

① Mounting valve
② Pipe thread

TM 80 rad







① PTFE sealing ring

Mounting valve and adapter

① Pipe thread
② O ring (NBR)

Combined thermometer/pressure gauges / thermo-hydrometers TM/TH

DG: G, PG: 2

Type	TM 63, D211	TM 63, D211	TM 80, D111	TM 80, D201	TM 80, D211	TM 80, D211	TH 80, D211
Version							
Housing Ø	63	63	80	80	80	80	80
Housing	Sheet steel, black		Plastic (ABS) highly impact resistant	Sheet steel, black	Sheet steel, black		
Accuracy class	Pressure gauge/hydrometer 2.5						
Connection	G¼B with mounting valve G¼ to R½						
Adapter	Without	With	Without	Without	Without	With	Without
Range	Part no.	Part no.	Part no.	Part no.	Part no.	Part no.	Part no.
Price €							
0/4 bar 20/120 °C	63318	63346	63317	63337	63341	63348	---
0/6 bar 20/120 °C	---	---	---	63338	63342	---	---
0/10 bar 20/120 °C	---	---	---	63339	63343	---	---
0/6 mWC 20/120 °C	---	---	---	---	---	---	63311
0/10 mWC 20/120 °C	---	---	---	---	---	---	63312
0/16 mWC 20/120 °C	---	---	---	---	---	---	63313
0/25 mWC 20/120 °C	---	---	---	---	---	---	63314
0/40 mWC 20/120 °C	---	---	---	---	---	---	63315
0/60 mWC 20/120 °C	---	---	---	---	---	---	63316

* Minimum order quantity for non-stock items = 100 pieces.

12

Spare parts

DG: G, PG: 2	Part no.	Price €
Adapter G¼ to M18 x 1, brass	05 00 40 01	



See accessories for pressure gauges for mounting valves

Bimetal thermometers with plastic housing for heating/plumbing applications



BiTh 40 K with plug-on

Application Heating, plumbing, distribution systems, underfloor heating manifolds

Technical specifications

Nominal size
40

Measuring element
Bimetal spiral

Ranges
0/60 °C

Application area
Full scale value

Operating pressure
No pressure

Standard version

Connection
Plastic, plug-on,
Ø 15 mm, no thermowell

Mounting position
Centre back

Dial
Plastic, white –
dial marking black

Pointer
Plastic, black

Housing
ABS, white

Window
Clip-on plastic



BiTh 50 K with plastic thermowell

Heating, plumbing, distribution systems, underfloor heating manifolds

Nominal size
50

Measuring element
Bimetal helix

Ranges
0/60 °C

Application area
Full scale value

Operating pressure at thermowell
6 bar maximum

Connection
Stem plastic,
Ø 9 mm, thermowell G $\frac{1}{2}$ B,
plastic, removable

Mounting position
Centre back

Dial
Plastic, white –
dial marking black

Pointer
Plastic, black

Housing
ABS, white

Window
Clip-in plastic



BiTh 63 K with brass thermowell

Heating, plumbing

Nominal size
63 – 80 – 100

Measuring element
Bimetal helix

Ranges
-20/+60, 0/60, 0/120 °C

Application area
Full scale value

Operating pressure at thermowell
6 bar maximum

Connection
Stem plastic, brass or aluminium,
Ø 9 mm, thermowell G $\frac{1}{2}$ B,
brass, removable, stem length
40 mm or thread, self-sealing,
with PTFE sealing ring

Mounting position
Centre back
(NG 63 bottom back optional)

Dial
Plastic, white –
dial marking black

Pointer
Plastic, black

Housing
ABS, black

Window
Clip-in plastic

Bimetal thermometers for heating and plumbing applications

Housing types and dimensions (mm)

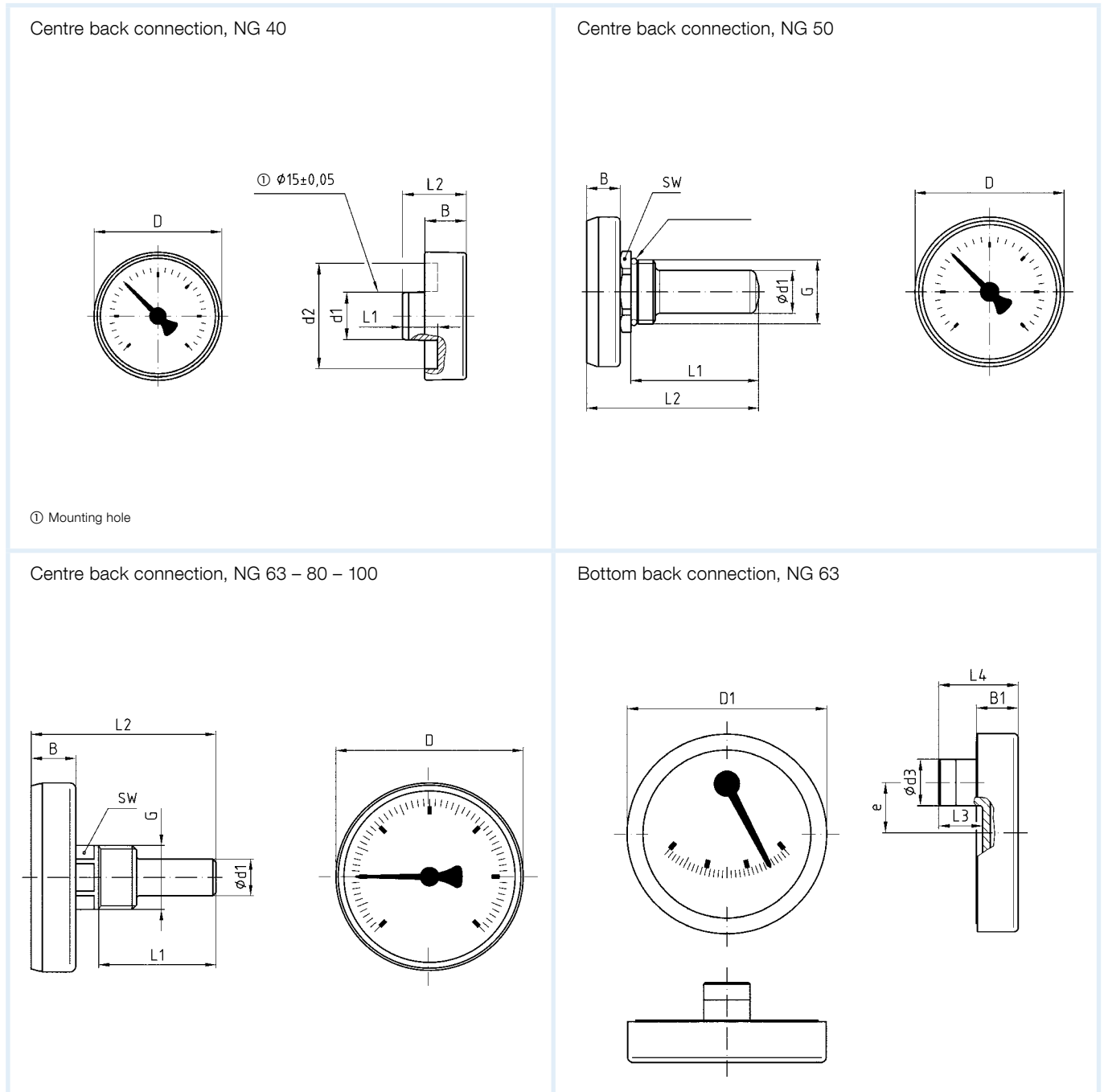

12

Dimensions (mm)

Nominal size (NG)	B	B ₁	D	D ₁	d ₁	d ₂	d ₃	e	G	L ₁	L ₂	L ₃	L ₄	SW
40	13	–	40	–	14.8	33	–	–	–	11	50	–	–	–
50	11	–	49	–	14	–	–	–	G _{1/2} B	42	56.5	–	–	24
63	14.7	13	62	63.5	12	–	15	16	G _{1/2} B	40/63/100/ 150/200	61/85/122/ 172/222	14	25	19
80	14.8	–	79	–	12	–	–	G _{1/2} B	–			–	19	
100	15	–	100	–	12	–	–	G _{1/2} B	–			–	19	

Bimetal thermometers for heating and plumbing applications

DG: G, PG: 1

DG: G, PG: 2

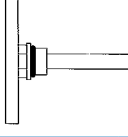
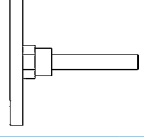
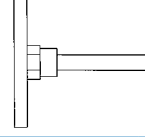
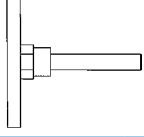
Type	BiTh 40 K	BiTh 50 K	BiTh 63 K	BiTh 80 K	BiTh 100 K					
Version										
Housing Ø	40	50	63	80	100					
Housing	Plastic (ABS), white		Plastic (ABS), black, window (plastic clip-in)							
Stem	Plastic, Ø 15 mm	Plastic, Ø 9 mm	Plastic, brass or aluminium, Ø 9 mm							
Connection	Plastic, plug-on, no thermowell	Thermowell G½B, plastic	Thermowell G½B brass, Ø 12 mm outside, removable							
Accuracy class	Class 2 as per EN 13190									
Range (bar)	-20/+60 °C	-20/+60 °C	-20/+60 °C	-20/+60 °C	-20/+60 °C					
Stem length		PU*	PU*	Price € Part no.	PU*	Price € Part no.	PU*	Price € Part no.	PU*	
40 mm	---			63763	100	63776	100	63676	50	
63 mm	---			63769	100	63777	100	63677	50	
100 mm	---			63770	100	63778	50	63678	50	
150 mm	---			63771	50	63779	40	63679	25	
Range	0/60 °C	0/60 °C	0/60 °C	0/60 °C	0/60 °C	0/60 °C	0/60 °C	0/60 °C	0/60 °C	
Stem length	Price € Part no.		Price € Part no.		Price € Part no.		Price € Part no.		Price € Part no.	
40 mm	64066 (See drawing for stem)	100	63749	100	63760	100	63765	100	63698	50
63 mm			---		63761	100	63766	100	63699	50
100 mm			---		63762	100	63767	50	63700	50
150 mm			---		63764	50	63768	40	63701	52
Range	0/120 °C	0/120 °C	0/120 °C	0/120 °C	0/120 °C	0/120 °C	0/120 °C	0/120 °C	0/120 °C	
Stem length	Price € Part no.		Price € Part no.		Price € Part no.		Price € Part no.		Price € Part no.	
40 mm with PTFE sealing ring	---		---		63702	100	63706	100	63684	50
40 mm	---		---		63704	100	63708	100	63997	50
63 mm	---		---		63710	100	63715	100	63695	50
100 mm	---		---		63711	100	63716	50	63696	50
150 mm	---		---		63714	50	63717	40	63697	25
200 mm	---		---		---				63671	10

* Minimum order quantity for non-stock items 1 PU (packing unit); delivery only in packing units.

Spare thermowells

Connection G½B, brass			
Stem length	PG	Part no.	Price
40 mm with PTFE sealing ring	2	63685	
40 mm	2	63856	
63 mm	2	63686	
100 mm	2	63687	
150 mm	2	63688	

Standard bimetal thermometers/surface mount bimetal thermometers/flue gas thermometers



Bimetal standard thermometers

Application Heating, plumbing

Technical specifications

Nominal size
50 – 63 – 80 – 100

Measuring element
Bimetal helix

Accuracy class
2 (EN 13190)

Ranges °C
-20/+60, 0/60, 0/120, 0/160

Application area
Full scale value

Operating pressure at thermowell
6 bar maximum

Standard version

Connection
Stem plastic, brass or aluminium, Ø 9 mm
Thermowell G $\frac{1}{2}$ B, brass, removable (160 °C and higher with locking screw)

Mounting position
NG 50 – 63 – 80 – 100
NG 63 – 80 – 100 bottom

Dial
Up to 120 °C plastic, greater than 160 °C aluminium, white
Dial marking black

Pointer
Plastic, black

Housing
Sheet steel galvanised

Push on bezel
Sheet steel nickel-plated

Window
Plastic

Options

- Other ranges
- Nominal size 34, 160

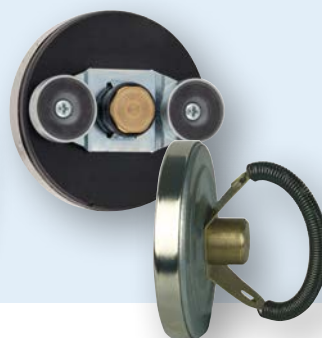

Surface mount thermometer ATH

Heating, ventilation and plumbing. Fastening by means of spring (ATH Ø F), magnet (ATH Ø M) or universal clamp (ATH Ø S)

Nominal size
63 – 80

Measuring element
Bimetal spiral

Ranges °C
-20/+40, 0/60, 0/120

Application area
Full scale value

Connection
ATH Ø F: With heat-conducting element and universal clamp;
ATH Ø S with universal clamp for pipes $\frac{3}{8}$ " to $1\frac{1}{2}$ ".
ATH Ø M: 2 x magnet Ø2 0 mm

Mounting position
NG 63 – 80 centre back

Dial
Plastic, white;
dial marking black

Pointer
Plastic, black

Housing
ATH Ø F: Sheet steel, galvanised
ATH Ø M: Plastic, black
ATH Ø S: Sheet steel, galvanised

Push on bezel
Sheet steel nickel-plated

Window
Plastic

- Other ranges
- Plastic housing



Flue gas thermometer RT / flue gas temperature controller RTC

Flue gas thermometer RT and flue gas temperature controller RTC for gas and oil-fired systems

Nominal size
80

Measuring element
Bimetal helix

Ranges °C
RT: 0/300, 0/500
RTC: 0/350

Application area
Full scale value

Connection
RT: Stem stainless steel 316 L, plain, with adjustable cone, brass
RTC: Stem stainless steel 316 L, plain, with ring magnet bracket

Mounting position
Centre back

Dial
Aluminium, grey dial marking black; RTC with green and red reference zones

Pointer
Aluminium, black
RTC with additional max. pointer, red

Housing
Sheet steel galvanised

Push on bezel
Sheet steel nickel-plated

Window
Plastic



See page 369 for prices.

Bimetal standard thermometers/surface mount thermometers/flue gas thermometers

Housing types and dimensions (mm)

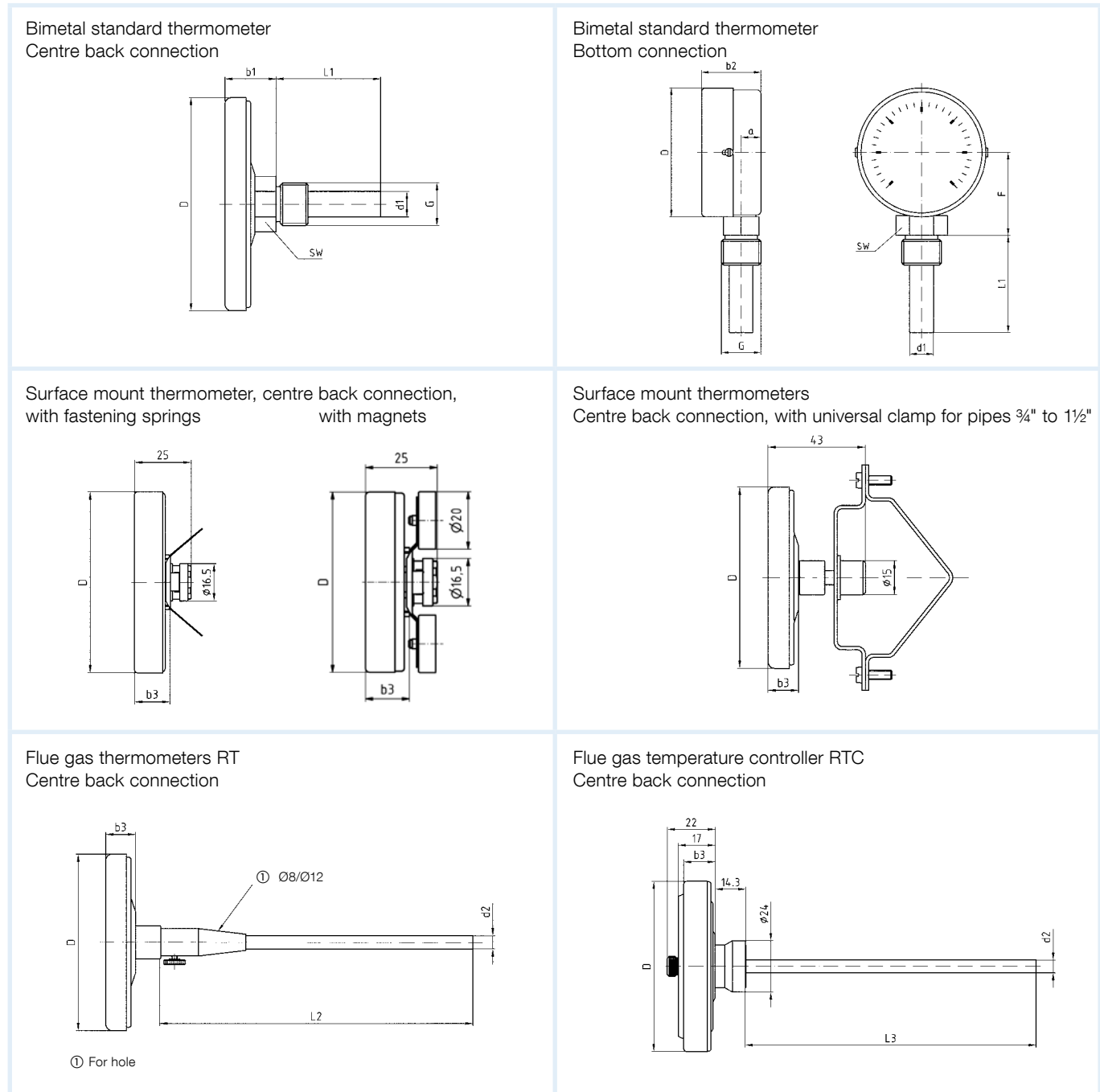

Dimensions (mm)

Nominal size (NG)	a	b ₁	b ₂	b ₃	D	d ₁	d ₂	F	G	L ₁	L ₂	L ₃	SW
50	-	18	-	-	50	12	-	-	G _{1/2} B	40	141 191 291	86 136	19/22
63	10	20	35	15	63	12	-	29.3	G _{1/2} B	63			19/22
80	10	21	33	15	80	12	6	47.3	G _{1/2} B	100			19/22
100	10	23.7	40.5	-	100	12	-	59.3	G _{1/2} B	150			19/22

Bimetal standard thermometer

DG: G, PG: 2

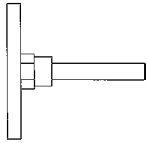
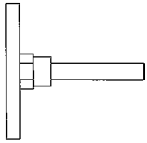
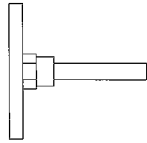
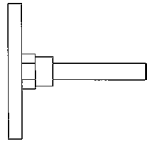
Type	BiTh 50 ST	BiTh 63 ST	BiTh 80 ST	BiTh 100 ST
Version				
Housing Ø	50	63	80	100
Housing	Sheet steel, galvanised, push on bezel nickel-plated, plastic window			
Stem	Plastic, brass or aluminium, Ø 9 mm			
Connection	Thermowell G½B, brass, Ø 12 mm outside, removable*			
Accuracy class	Class 2 as per EN 13190			
Range	-20/+60 °C	-20/+60 °C	-20/+60 °C	-20/+60 °C
Stem length		Price € Part no.	Price € Part no.	Price € Part no.
40 mm	---	63951	63955	63959
63 mm	---	63952	63956	63960
100 mm	---	63953	63957	63961
150 mm	---	63954	63958	63962
Range	0/60 °C	0/60 °C	0/60 °C	0/60 °C
Stem length	Price € Part no.	Price € Part no.	Price € Part no.	Price € Part no.
40 mm	64027B	63860	63865	63869
63 mm	64028B	63861	63866	63870
100 mm	64029B	63862	63867	63871
150 mm	64030B	63864	63868	63872
Range	0/120 °C	0/120 °C	0/120 °C	0/120 °C
Stem length	Price € Part no.	Price € Part no.	Price € Part no.	Price € Part no.
40 mm	64031B	63801	63806	63811
63 mm	64032B	63802	63807	63812
100 mm	64033B	63803	63808	63813
150 mm	64034B	63804	63809	63814
200 mm	---	---	63842	63815
Range	0/160 °C	0/160 °C**	0/160 °C**	0/160 °C**
Stem length		Price € Part no.	Price € Part no.	Price € Part no.
40 mm	---	63983***	63987	64015
63 mm	---	63984	63988	64016
100 mm	---	63985	63989	64017
150 mm	---	63986	63990	64018

Minimum order quantity for non-stock items = 25 pieces.

* NG 50 with O ring clamp connection.

** 160 °C and higher = Thermowell with locking screw.

*** Dial red = Part no. **63674**; extra charge € / Dial blue = Part no. **63675**; extra charge €

Bimetal standard thermometer

DG: H, PG: 2

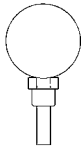
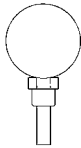
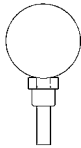
Type	BiTh 63 ST	BiTh 80 ST	BiTh 100 ST
Version			
Housing Ø	63	80	100
Housing	Sheet steel, galvanised, push on bezel nickel-plated, plastic window		
Stem	Brass or aluminium, Ø 9 mm		
Connection	Thermowell G½B, brass, Ø 12 mm outside, removable		
Accuracy class	Class 2 as per EN 13190		
Range	-20/+60 °C	-20/+60 °C	-20/+60 °C
Stem length	Price € Part no.	Price € Part no.	Price € Part no.
40 mm	64039	64055	64073
63 mm	64040	64056	64074
100 mm	64041	64057	64075
150 mm	64042	64058	64076
Range	0/60 °C	0/60 °C	0/60 °C
Stem length	Price € Part no.	Price € Part no.	Price € Part no.
40 mm	64043	64059	64077
63 mm	64044	64060	64078
100 mm	64045	64061	64079
150 mm	64046	64062	64080
Range	0/120 °C	0/120 °C	0/120 °C
Stem length	Price € Part no.	Price € Part no.	Price € Part no.
40 mm	64047	64063	64081
63 mm	64048	64064	64082
100 mm	64049	64067	64083
150 mm	64050	64068	64084

Minimum order quantity for non-stock items = 10 pieces.



Spare thermowells

DG: G, PG: 2

Connection G½B, brass (only for bottom connection)		
Stem length	Part no.	Price €
40 mm	63850	
63 mm	63851	
100 mm	63852	
150 mm	63853	

Surface mount thermometers/eccentric thermometers

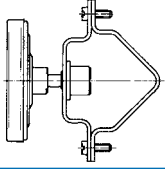
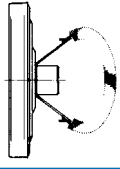
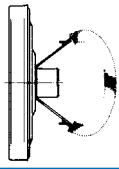
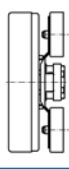
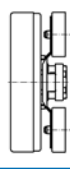
DG: G, PG: 3

Type	ATh 63 S	ATh 63 F*	ATh 80 F*	ATh 63 M	ATh 80 M	BiTh 63 exz
Version						
Housing Ø	63	63	80	63	80	63
Housing	Sheet steel, galvanised, push on bezel nickel-plated, plastic window			Plastic, black, push on bezel nickel-plated, plastic window		Plastic
Connection	Universal clamp for pipes 3/8" to 1 1/2"	Heat-conducting element with fastening spring for pipes 3/8" to 1 1/2"		2 x magnet Ø 20 mm		Eccentric male connector Ø 15 mm
Accuracy class	Class 2 as per EN 13190					
Range	0/120 °C	0/120 °C	0/120 °C	0/120 °C	0/120 °C	20/100 °C
	Price € Part no.	Price € Part no.	Price € Part no.	Price € Part no.	Price € Part no.	Price € Part no.
Dial black	63820	63822	63821	63651	63653	68895
Dial red	---	---	---	---	---	63920
Dial blue	---	---	---	---	---	63921
Range	0/60 °C	0/60 °C	0/60 °C	0/60 °C	0/60 °C	0/60 °C
	---	63826	63943	63650	63652	---
Range	---	-20/+40 °C	---	---	---	---
	---	64339	---	---	---	---

*ATh 63 F / ATh 80 F are also available with plastic housing.

Flue gas thermometers/flue gas temperature controllers

DG: G, PG: 3

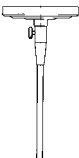
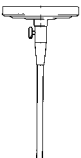
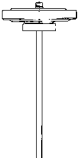
Type	RT 80	RT 80	RTC 80
Version			
Housing Ø	80	80	80
Housing	Sheet steel galvanised, push on bezel nickel-plated, plastic window		
Connection	Plain stem Stainless steel 316 L Adjustable cone Brass, nickel-plated 8-12 mm	Plain stem Stainless steel 316 L Adjustable cone Stainless steel 12-18 mm	Plain stem stainless steel 316, magnet
Accuracy class	Class 2 as per EN 13190		
Range	0/300 °C	0/500 °C	0/350 °C
Stem length	Price € Part no.	Price € Part no.	Price € Part no.
100 mm	---	---	63833
150 mm	64238	63830	64164
300 mm	64239	63831	---

12

Bimetal thermometer for industrial applications / Bimetal air duct thermometer



Bimetal thermometer for industrial applications

Technical specifications

Mechanical engineering, plant engineering, pipelines, boilers, heating technology

Type
D2

Nominal size
63 – 80 – 100 – 160

Measuring element
Bimetal helix

Accuracy class
1 (EN 13190)

Ranges °C
-20/+60, 0/60, 0/120, 0/160

Application area (EN 13190)
Continuous load: measuring range
Short-term: range

Operating pressure at thermowell
10 bar maximum (static)

Degree of protection
IP 41 (EN 60529)

Standard version

Connection
Stem brass, Ø 9 mm
Thermowell G½B, brass, removable

Mounting position
NG 63 – 80 – 100 – 160 centre back
NG 63 – 80 – 100 – 160 bottom

Dial
Aluminium, white,
Dial marking black

Pointer
Aluminium, black

Housing
Sheet steel galvanised

Push on bezel
Sheet steel nickel-plated

Window
Instrument glass

Options

- Other connection types
- Other ranges
- Other stem lengths



See page 374 for prices.



Bimetal air duct thermometer

Air conditioning, ventilation

Type
D2

Nominal size
63 – 80 – 100

Measuring element
Bimetal helix

Accuracy class
2 (EN 13190)

Ranges °C
-30/+50, -20/+60, -20/+40, 0/60

Application area
Full scale value

Degree of protection
IP 41 (EN 60529)

Connection
Stem brass, Ø 9 mm, mounting flange,
plastic Ø 60 mm, or back flange, steel

Mounting position
NG 63 – 80 – 100 centre back

Dial
Aluminium, white,
Dial marking black

Pointer
Plastic, black

Housing
Sheet steel galvanised

Push on bezel
Sheet steel nickel-plated

Window
Version LKF: Plastic
Version LKB: Instrument glass

- Other ranges
- Other stem lengths
- Accuracy class 1
- Steel flange Ø 40/80 mm

Bimetal thermometers for industrial applications / Bimetal air duct thermometer

Housing types and dimensions (mm)

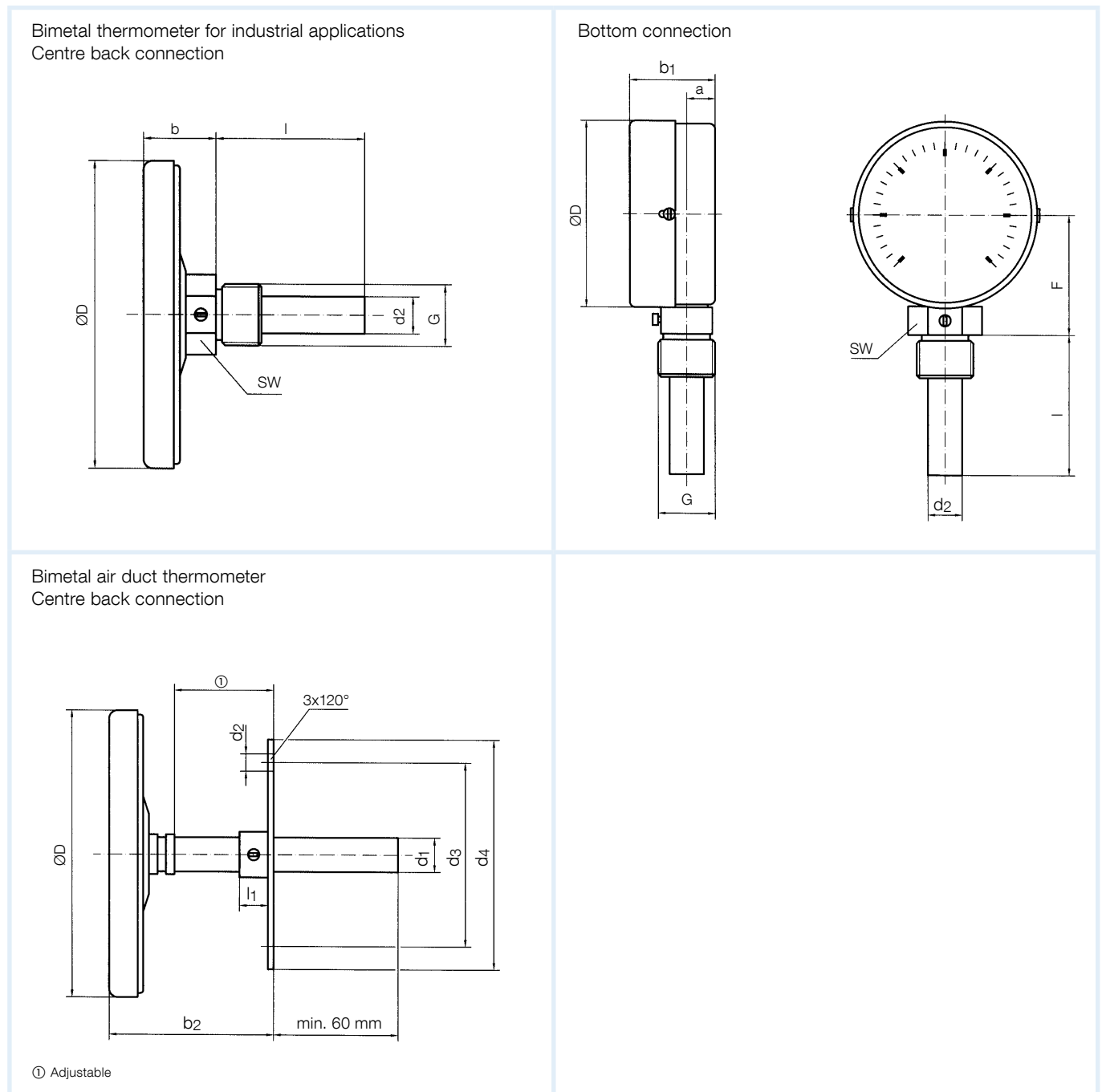

Dimensions (mm)

Nominal size (NG)	a	b	b ₁	b ₂	D	d ₁	d ₂	d ₃	d ₄	F	G	l	l ₁	SW
63	10	24	34	Adjustable	63	9	12	51	60	43,5	G½B	40	10	22
80	10	24	36		80	9	12	51	60	52	G½B	63	10	22
100	10	26	36		100	9	12	51	60	62	G½B	100	10	22
160	-	32	37		160	-	-	-	-	92	G½B	150	-	22

Bimetal thermometer for industrial applications

DG: H, PG: 2

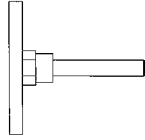
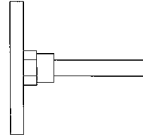
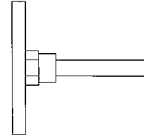
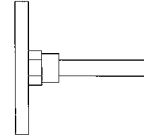
Type	BiTh 63 I D211	BiTh 80 I D211	BiTh 100 I D211	BiTh 160 I D211
Version				
Housing Ø	63	80	100	160
Housing	Sheet steel galvanised, push on bezel nickel-plated, instrument glass window			
Stem	Brass, Ø 9 mm			
Connection	Thermowell G½B, brass, Ø 12 mm outside, removable			
Accuracy class	Class 1 as per EN 13190			
Range	-20/+60 °C	-20/+60 °C	-20/+60 °C	-20/+60 °C
Stem length	Price € Part no.	Price € Part no.	Price € Part no.	Price € Part no.
40 mm	65106211	65206211	65306211	65406211
63 mm	65107211	65207211	65307211	65407211
100 mm	65108211	65208211	65308211	65408211
150 mm	65109211	65209211	65309211	65409211
Range	0/60 °C	0/60 °C	0/60 °C	0/60 °C
Stem length	Price € Part no.	Price € Part no.	Price € Part no.	Price € Part no.
40 mm	65131211	65231211	65331211	65431211
63 mm	65132211	65232211	65332211	65432211
100 mm	65133211	65233211	65333211	65433211
150 mm	65134211	65234211	65334211	65434211
Range	0/120 °C	0/120 °C	0/120 °C	0/120 °C
Stem length	Price € Part no.	Price € Part no.	Price € Part no.	Price € Part no.
40 mm	65146211	65246211	65346211	65446211
63 mm	65147211	65247211	65347211	65447211
100 mm	65148211	65248211	65348211	65448211
150 mm	65149211	65249211	65349211	65449211
Range	0/160 °C	0/160 °C	0/160 °C	0/160 °C
Stem length	Price € Part no.	Price € Part no.	Price € Part no.	Price € Part no.
40 mm	65151211	65251211	65351211	65451211
63 mm	65152211	65252211	65352211	65452211
100 mm	65153211	65253211	65353211	65453211
150 mm	65154211	65254211	65354211	65454211

Minimum order quantity for non-stock items = 10 pieces.

Bimetal thermometer for industrial applications

DG: H, PG: 2

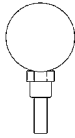
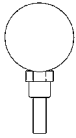
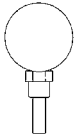
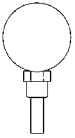
Type	BiTh 63 D201	BiTh 80 D201	BiTh 100 D201	BiTh 160 D201
Version				
Housing Ø	63	80	100	160
Housing	Sheet steel galvanised, push on bezel nickel-plated, instrument glass window			
Stem	Brass, Ø 9 mm			
Connection	Thermowell G½B, brass, Ø 12 mm outside, removable			
Accuracy class	Class 1 as per EN 13190			
Range	-20/+60 °C	-20/+60 °C	-20/+60 °C	-20/+60 °C
Stem length	Price € Part no.	Price € Part no.	Price € Part no.	Price € Part no.
40 mm	65106201	65206201	65306201	65406201
63 mm	65107201	65207201	65307201	65407201
100 mm	65108201	65208201	65308201	65408201
150 mm	65109201	65209201	65309201	65409201
Range	0/60 °C	0/60 °C	0/60 °C	0/60 °C
Stem length	Price € Part no.	Price € Part no.	Price € Part no.	Price € Part no.
40 mm	65131201	65231201	65331201	65431201
63 mm	65132201	65232201	65332201	65432201
100 mm	65133201	65233201	65333201	65433201
150 mm	65134201	65234201	65334201	65434201
Range	0/120 °C	0/120 °C	0/120 °C	0/120 °C
Stem length	Price € Part no.	Price € Part no.	Price € Part no.	Price € Part no.
40 mm	65146201	65246201	65346201	65446201
63 mm	65147201	65247201	65347201	65447201
100 mm	65148201	65248201	65348201	65448201
150 mm	65149201	65249201	65349201	65449201
Range	0/160 °C	0/160 °C	0/160 °C	0/160 °C
Stem length	Price € Part no.	Price € Part no.	Price € Part no.	Price € Part no.
40 mm	65151201	65251201	65351201	65451201
63 mm	65152201	65252201	65352201	65452201
100 mm	65153201	65253201	65353201	65453201
150 mm	65154201	65254201	65354201	65454201

Bimetal air duct thermometer

DG: H, PG: 2

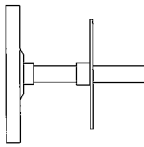
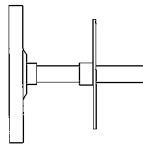
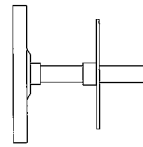
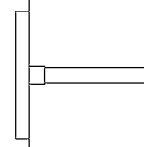
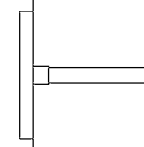
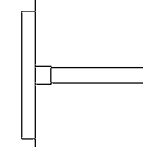
Type	BiTh 63 LKF D211	BiTh 80 LKF D211	BiTh 100 LKF D211	BiTh 63 LKB D271	BiTh 80 LKB D271	BiTh 100 LKB D271
Version						
Housing Ø	63	80	100	63	80	100
Housing	Sheet steel galvanised, push on bezel Nickel-plated, plastic window			Sheet steel galvanised, push on bezel Nickel-plated, with back flange Instrument glass window		
Stem	Brass, Ø 9 mm					
Connection	Flange, plastic, Ø 60 mm			Plain		
Accuracy class	Class 2 as per EN 13190					
Range	-30/+50 °C	-30/+50 °C	-30/+50 °C	-30/+50 °C	-30/+50 °C	-30/+50 °C
Stem length	Price € Part no.	Price € Part no.	Price € Part no.	Price € Part no.	Price € Part no.	Price € Part no.
100 mm	65613211	65713211	65813211	65613271	65713271	65813271
150 mm	65614211	65714211	65814211	65614271	65714271	65814271
200 mm	65615211	65715211	65815211	65615271	65715271	65815271
Range	-20/+60 °C	-20/+60 °C	-20/+60 °C	-20/+60 °C	-20/+60 °C	-20/+60 °C
Stem length	Price € Part no.	Price € Part no.	Price € Part no.	Price € Part no.	Price € Part no.	Price € Part no.
100 mm	65608211	65708211	65808211	65608271	65708271	65808271
150 mm	65609211	65709211	65809211	65609271	65709271	65809271
200 mm	65610211	65710211	65810211	65610271	65710271	65810271
Range	-20/+40 °C	-20/+40 °C	-20/+40 °C	-20/+40 °C	-20/+40 °C	-20/+40 °C
Stem length	Price € Part no.	Price € Part no.	Price € Part no.	Price € Part no.	Price € Part no.	Price € Part no.
100 mm	65623211	65723211	65823211	65623271	65723271	65823271
150 mm	65624211	65724211	65824211	65624271	65724271	65824271
200 mm	65625211	65725211	65825211	65625271	65725271	65825271
Range	0/60 °C	0/60 °C	0/60 °C	0/60 °C	0/60 °C	0/60 °C
Stem length	Price € Part no.	Price € Part no.	Price € Part no.	Price € Part no.	Price € Part no.	Price € Part no.
100 mm	65633211	65733211	65833211	65633271	65733271	65833271
150 mm	65634211	65734211	65834211	65634271	65734271	65834271
200 mm	65635211	65735211	65835211	65635271	65735271	65835271

Minimum order quantity for non-stock items = 10 pieces.

Bimetal stainless steel thermometer



- Suitable for use in plant engineering
- Accuracy class 1 as per EN 13190
- For temperatures of the medium of up to 160 °C



With adapter ring for thermowell
Ø 18 mm

Application For corrosive media. Versatile application.

Technical specifications

Type: D3

Nominal size: 63 – 80 – 100

Measuring element: Bimetal helix

Accuracy class: 1 (EN 13190)

Ranges °C

-20/+60, 0/60, 0/120, 0/160

Application area (EN 13190)

Continuous load: measuring range

Short-term: range

Operating pressure at thermowell

6 bar maximum

Degree of protection: IP 43 (EN 60529)

Standard version

Connection

Stem stainless steel 316 L, Ø 8 mm, plain

Adapter ring

Plastic, for thermowells with connection collar Ø 14, 18 mm (only for axial mounting position up to max. 120 °C)

Mounting position

NG 63 – 80 – 100 centre back

NG 63 – 100 bottom

Dial

Aluminium, white – Dial marking black

Pointer: Aluminium, black

Housing and push on bezel: Stainless steel 304

Window: Instrument glass

Options

- Thermowell G1½B, stainless steel 316 Ti/316 L
- Other connection designs
- Other ranges
- Other stem lengths



See page 379 for prices.

Bimetal stainless steel thermometer

Housing types and dimensions (mm)

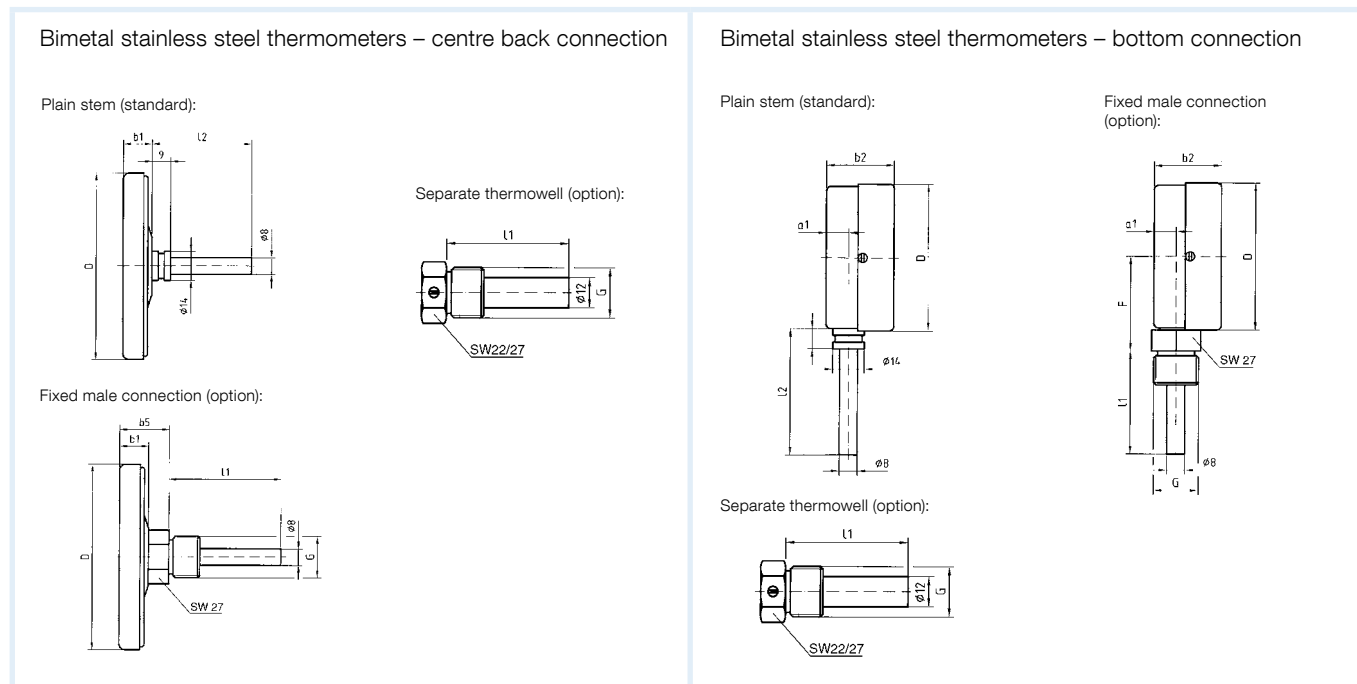

Dimensions (mm)

Nominal size (NG)	D	a1	a2	b1	b2	b3	b4	b5	b6	F	F1	G	l1	l2
63	63	10	15.5	15	34	32	45	27	62	46.5	58.5	G½B	40	49
80	80	-	-	15	-	-	-	28	-	-	-	G½B	63	67
													100	104
100	100	10	17.5	17	36	27.5	49.5	29	57.5	65	77.5	G½B	150	154

Bimetal stainless steel thermometer

DG: H, PG: 3

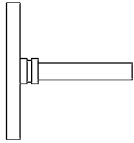
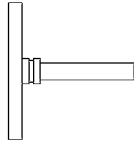
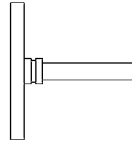
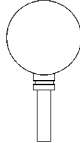
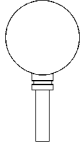
Type	BiTh 63 E D312	BiTh 80 E D312	BiTh 100 E D312	BiTh 63 E D302	BiTh 100 E D302
Version					
Housing Ø	63	80	100	63	100
Housing	Stainless steel 304 with push on bezel 304, instrument glass window				
Stem	Stainless steel 316 L, Ø 8 mm				
Connection	Plain stem (without thermowell)				
Accuracy class	Class 1 as per EN 13190				
Range	-20/+60 °C	-20/+60 °C	-20/+60 °C	-20/+60 °C	-20/+60 °C
For thermowell with stem length L1	Price € Part no.	Price € Part no.	Price € Part no.	Price € Part no.	Price € Part no.
63 mm	66107312	66207312	66307312	66107302	66307302
100 mm	66108312	66208312	66308312	66108302	66308302
150 mm	66109312	66209312	66309312	66109302	66309302
200 mm	66110312	66210312	66310312	66110302	66310302
Range	0/60 °C	0/60 °C	0/60 °C	0/60 °C	0/60 °C
For thermowell with stem length L1	Price € Part no.	Price € Part no.	Price € Part no.	Price € Part no.	Price € Part no.
63 mm	66132312	66232312	66332312	66132302	66332302
100 mm	66133312	66233312	66333312	66133302	66333302
150 mm	66134312	66234312	66334312	66134302	66334302
200 mm	66135312	66235312	66335312	66135302	66335302
Range	0/120 °C	0/120 °C	0/120 °C	0/120 °C	0/120 °C
For thermowell with stem length L1	Price € Part no.	Price € Part no.	Price € Part no.	Price € Part no.	Price € Part no.
40 mm	66146312	66246312	66346312	---	---
63 mm	66147312	66247312	66347312	66147302	66347302
100 mm	66148312	66248312	66348312	66148302	66348302
150 mm	66149312	66249312	66349312	66149302	66349302
200 mm	66150312	66250312	66350312	66150302	66350302
Range	0/160 °C	0/160 °C	0/160 °C	0/160 °C	0/160 °C
For thermowell with stem length L1	Price € Part no.	Price € Part no.	Price € Part no.	Price € Part no.	Price € Part no.
63 mm	66152312	66252312	66352312	66152302	66352302
100 mm	66153312	66253312	66353312	66153302	66353302
150 mm	66154312	66254312	66354312	66154302	66354302
200 mm	66155312	66255312	66355312	66155302	66355302

Minimum order quantity for non-stock items = 10 pieces.

Blue part no. = in-stock items



* See page 381 for other connection types, options/extra charges.

Bimetal stainless steel thermometers with fixed connection thread

DG: H, PG: 3

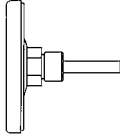
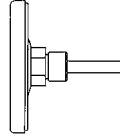
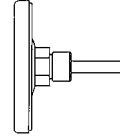
Type	BiTh 63 E D312	BiTh 80 E D312	BiTh 100 E D312
Version			
Housing Ø	63	80	100
Housing	Stainless steel 304 with push on bezel 304, instrument glass window		
Stem	Stainless steel 316 L, Ø 8 mm		
Connection	Fixed male connection, fixed G1/2B**		
Accuracy class	Class 1 as per EN 13190		
Range	0/60 °C	0/60 °C	0/60 °C
Stem length L1*	Price € Part no.	Price € Part no.	Price € Part no.
63 mm	66132312AFG4D8	66232312AFG4D8	66332312AFG4D8
100 mm	66133312AFG4D8	66233312AFG4D8	66333312AFG4D8
150 mm	66134312AFG4D8	66234312AFG4D8	66334312AFG4D8
200 mm	66135312AFG4D8	66235312AFG4D8	66335312AFG4D8
Range	0/120 °C	0/120 °C	0/120 °C
Stem length L1*	Price € Part no.	Price € Part no.	Price € Part no.
63 mm	66147312AFG4D8	66247312AFG4D8	66347312AFG4D8
100 mm	66148312AFG4D8	66248312AFG4D8	66348312AFG4D8
150 mm	66149312AFG4D8	66249312AFG4D8	66349312AFG4D8
200 mm	66150312AFG4D8	66250312AFG4D8	66350312AFG4D8
Range	0/160 °C	0/160 °C	0/160 °C
Stem length L1*	Price € Part no.	Price € Part no.	Price € Part no.
63 mm	66152312AFG4D8	66252312AFG4D8	66352312AFG4D8
100 mm	66153312AFG4D8	66253312AFG4D8	66353312AFG4D8
150 mm	66154312AFG4D8	66254312AFG4D8	66354312AFG4D8
200 mm	66155312AFG4D8	66255312AFG4D8	66355312AFG4D8

Minimum order quantity for non-stock items = 10 pieces.

Blue part no. = in-stock items

* Maximum stem length = 300 mm.

** 1/2-14 NPT available at no extra charge.

Connection types for bimetal thermometers

(industrial, stainless steel and chemical versions)

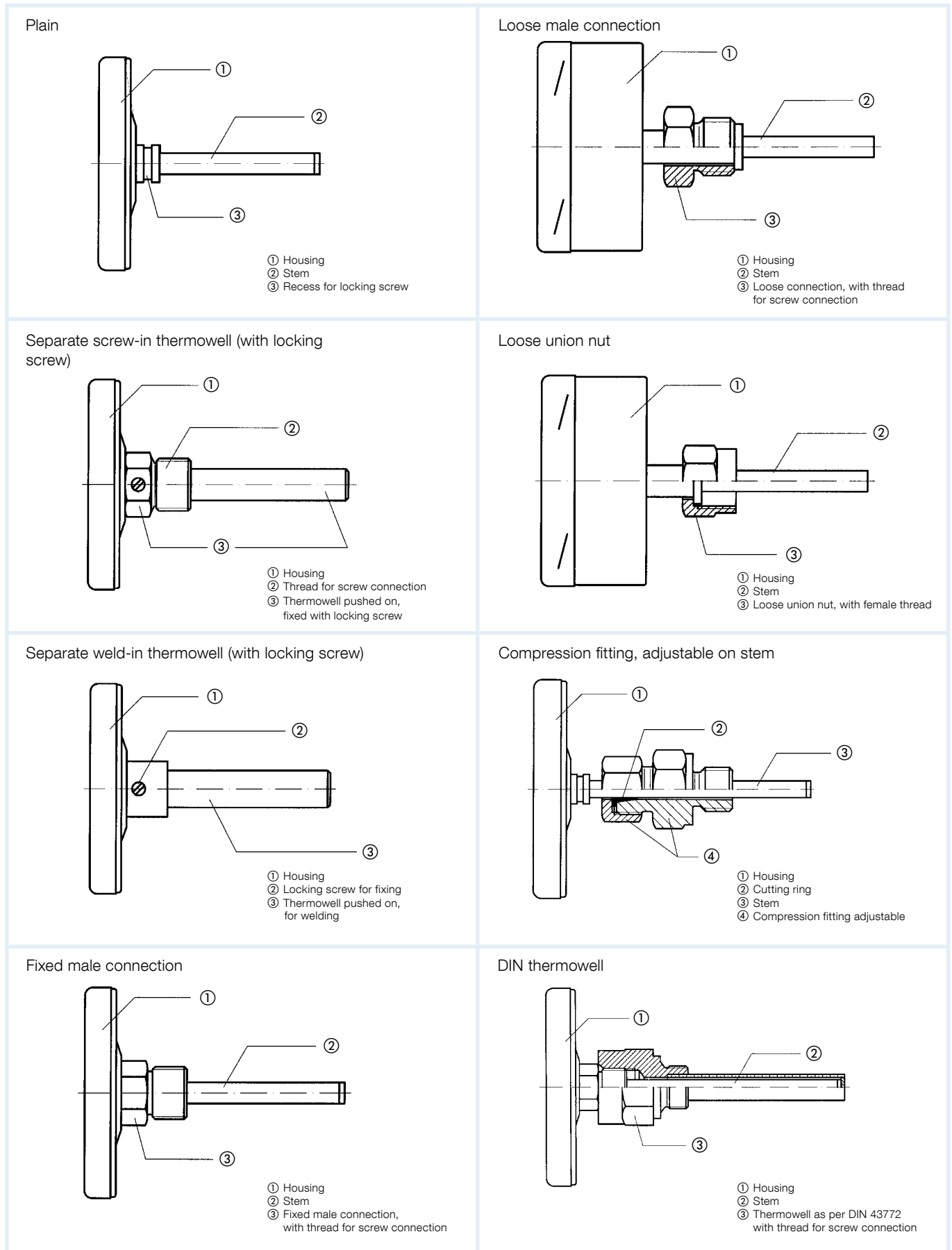

See catalogue INDUSTRIAL TECHNOLOGY, chapter 4, for extra charges and part numbers for connection types and other ranges.

Industrial thermometers VMTh

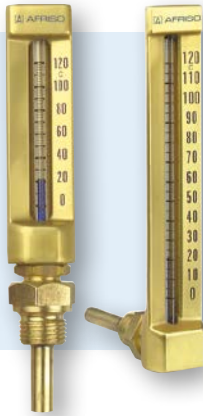

- Extremely robust due to full metal housing
- Vibration-resistant glass thermometers
- Stainless steel version possible
- Excellent readability due to blue thermometer filling



Application Heating, industry, mechanical engineering

Technical specifications

Nominal size
110 x 30 – 150 x 36 – 200 x 36

Upper part

Aluminium, V-shaped, polished, anodised brass-coloured. Numbers of measuring range printed in black at the right part of the scale below the anodised layer. Adjustable by means of brass nut (spanner size SW 22) so that readings from any angle are possible.

Glass insert (capillary)

Prismatic capillary, completely made of glass, Ø 6 mm. Graduation marks of the capillary burnt in, black, completely resistant. Main graduation marks corresponding to the numbers printed on the housing are especially bold and easy to read.

Thermometer filling

Standard version:
Blue liquid indicating from -60 to +200 °C.

Stem

Brass, Ø 10 mm, with fixed thread G½B.
Stainless steel version on request.

Accuracy

DIN 16195

Ranges °C

-30/+50, 0/60, 0/100, 0/120, 0/160

Mounting position

Straight
Angled 90°
Angled 135°

Stem lengths (mm)

40, 63, 100, 160

Housing types and dimensions (mm)

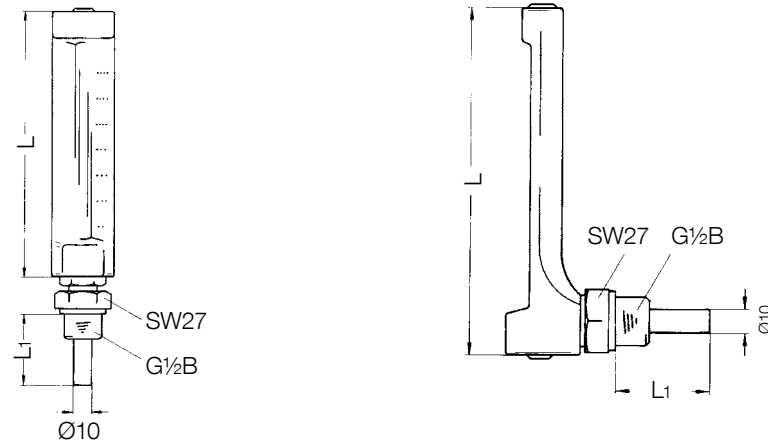







Options

- Other ranges
- Other stem lengths
- Other stem materials
- Other connection threads
- Upper part anodised aluminium-coloured
- Upper part made of plastic
- Thermowells

Type	L	L1
VMTh 110	110	40
VMTh 150	150	63
VMTh 200	200	160

Industrial thermometers VMTh

DG: H, PG: 2

Type	VMTh 110	VMTh 110	VMTh 150	VMTh 150	VMTh 200	VMTh 200
Version						
Nominal size	110 x 30	110 x 30	150 x 36	150 x 36	200 x 36	200 x 36
DIN	16181	16182	16185	16186	16189	16190
Mounting position	Straight	Angled 90° ¹⁾	Straight	Angled 90° ¹⁾	Straight	Angled 90° ¹⁾
Housing	Aluminium, anodised brass-coloured					
Stem	Brass, Ø 10 mm					
Connection	Version B with screw-in socket G½B, brass ²⁾					
Accuracy	As per DIN 16195					
Range	-30/+50 °C	-30/+50 °C	-30/+50 °C	-30/+50 °C	-30/+50 °C	-30/+50 °C
Stem length	Price € Part no.	Price € Part no.	Price € Part no.	Price € Part no.	Price € Part no.	Price € Part no.
40 mm	64101	64120	64136	64150	---	---
63 mm	64102	64121	64137	64151	64165	64181
100 mm	64103	64122	64138	64152	64166	64182
160 mm	64104	64123	64139	64153	64167	64183
Range	0/60 °C	0/60 °C	0/60 °C	0/60 °C	0/60 °C	0/60 °C
Stem length	Price € Part no.	Price € Part no.	Price € Part no.	Price € Part no.	Price € Part no.	Price € Part no.
40 mm	64106	64124	64140	64154	---	---
63 mm	64107	64125	64141	64155	64169	64185
100 mm	64108	64126	64142	64156	64170	64186
160 mm	64109	64127	64143	64157	64171	64187
Range	0/100 °C	0/100 °C	0/100 °C	0/100 °C	0/100 °C	0/100 °C
Stem length	Price € Part no.	Price € Part no.	Price € Part no.	Price € Part no.	Price € Part no.	Price € Part no.
40 mm	---	---	64330	64335	---	---
63 mm	---	---	64331	64336	---	---
100 mm	---	---	64332	64337	---	---
160 mm	---	---	64333	64338	---	---
Range	0/120 °C	0/120 °C	0/120 °C	0/120 °C	0/120 °C	0/120 °C
Stem length	Price € Part no.	Price € Part no.	Price € Part no.	Price € Part no.	Price € Part no.	Price € Part no.
40 mm	64111	64128	64100	64110	---	---
63 mm	64112	64129	64105	64115	64173	64189
100 mm	64113	64130	64144	64158	64174	64190
160 mm	64114	64131	64145	64159	64175	64191
Range	0/160 °C	0/160 °C	0/160 °C	0/160 °C	0/160 °C	0/160 °C
Stem length	Price € Part no.	Price € Part no.	Price € Part no.	Price € Part no.	Price € Part no.	Price € Part no.
40 mm	64116	64132	64146	64160	---	---
63 mm	64117	64133	64147	64161	64177	64193
100 mm	64118	64134	64148	64162	64178	64194
160 mm	64119	64135	64149	64163	64179	64195

¹⁾ Version with mounting position 135° on request. ²⁾ Extra charge for stainless steel screw-in socket: €. Minimum order quantity for non-stock items = 10 pieces.

Temperature control thermostats TRT with capillary tube



- Mechanical temperature controllers
- For controlling and monitoring thermal processes
- Ideal for heat and process engineering
- Simple, robust design



Application Mechanical temperature controller and limiter without external power supply. The device is suitable for application areas in the field of heat and process engineering. With the liquid-filled measuring systems and the short response times, the devices lend themselves for controlling thermal processes in appliance engineering, ovens, heating and air conditioning and other industrial or domestic applications.

Description The temperature measured at the probe causes a change in the volume of the measuring liquid in the probe-capillary system. Electrical switching is triggered by the force acting. A thermowell allows for pressure-tight installation of the probe in various types of pressurised tanks.

Technical specifications

Type
TR 2

Operating range
0/90 °C

Tolerance
±6 K at 20 °C

Influence of ambient temperature
-0.054 °C/°C

Switching differential
ΔT 4 ±1K

Adjustment angle
270°

Probe element
Liquid-filled
Ø 6.5 x 95 mm

Operating temperature range
Probe: Max. 130 °C
Housing: Max. 90 °C

Probe and capillary tube
Copper

Capillary length
Cu capillary tube with PVC coating, black
L = 1,000, 1,500 mm

Degree of protection
IP 00 (EN 60529)

Time constant
DIN-tested
DIN EN 14597:2012-09
Registration number TR/STB 1211

Electrical switching contact
Changeover contact

Contact rating
NC 16 (6) A 250 V AC
NO 6(4)A 250 V AC

- Options**
- Other operating ranges
 - Other capillary tube lengths
 - Customised versions



See page 388 for prices.

Temperature control thermostats TRT with capillary tube

Housing types and dimensions (mm)

Temperature control thermostat TRT, housing dimensions with adjustment angle

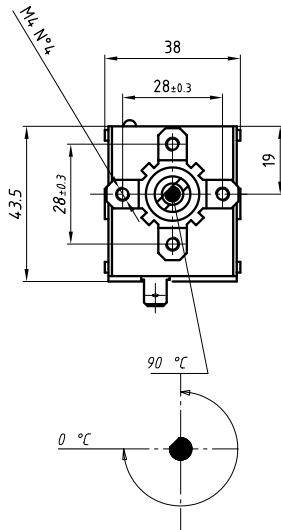

Temperature control thermostat TRT, housing dimensions and probe dimensions

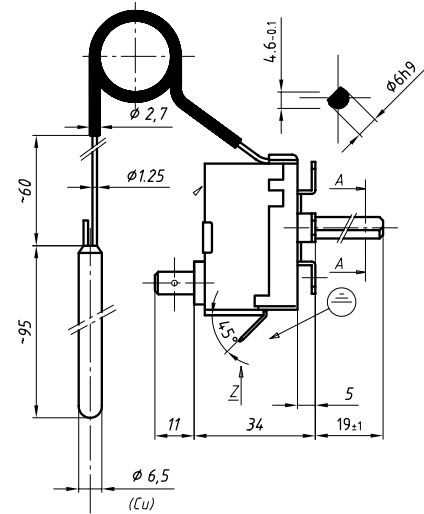

Connections (view Z)

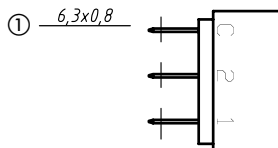

① Connections

Switching scheme

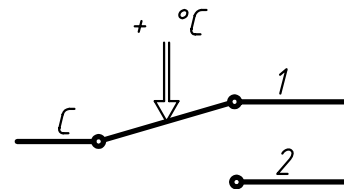

Safety temperature cut outs STB with capillary tube



- Ideal for heating and process industries
- For protection against exceeding the maximum temperature
- No external power supply
- Manual reset

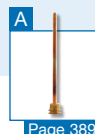

Page 389

Application There are many application areas for safety temperature cut outs in the heating and process industries. In conventional oil-fired or gas-fired boilers, these devices are used to monitor the boiler water. The safety temperature cut outs feature a manual reset button which must be actuated for unlocking.

Description If the temperature at the probe increases, the measuring liquid in the measuring system expands. If the temperature exceeds a critical value, the device triggers, the voltage-free contact switches and the system is set to a defined safe state. When the temperature has decreased by approx. 15 K, the device can be unlocked and the system resumes operation.

Technical specifications

Type
LS1

Switching point
100 °C

Tolerance
+0 K
-6 K at 20 °C

Influence of ambient temperature
0.25 °C/°C

Switching differential
 ΔT 15 ±8 K

Fail safe
Yes

Probe element
Liquid-filled
Ø 6.5 x 95 mm

Operating temperature range
Probe: Max. 125 °C
Housing: Max. 85 °C

Probe and capillary tube
Copper

Capillary length
Cu capillary tube with PVC coating, black
L = 1,000, 1,500 mm

Degree of protection housing
IP 00 (EN 60529)

Time constant
DIN-tested
DIN EN 14597:2012-09
Registration number TR/STB 1211

Electrical switching contact
Changeover contact

Contact rating
NC 16 (2.5) A 250 V AC
NO 0.5 A 250 V AC

- Options**
- Other operating ranges
 - Other capillary tube lengths
 - Customised versions



See page 388 for prices.

Safety temperature cut outs STB with capillary tube

Housing types and dimensions (mm)

Housing dimensions STB

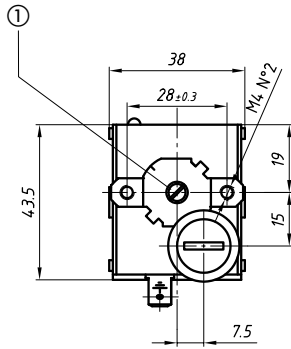

① Sealing wax

Housing and probe dimensions STB

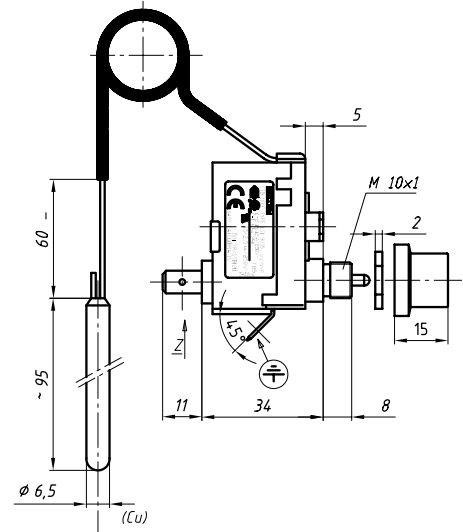

Connections (view Z)

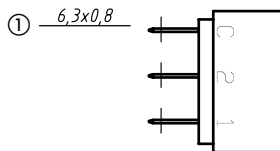

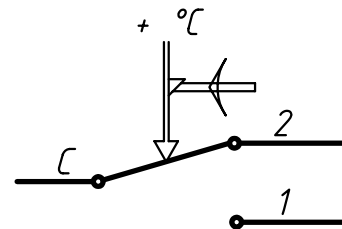

① Connections

Switching scheme



Temperature control thermostats TRT and safety temperature cut outs STB with capillary tube

DG: G, PG: 4	Contact	Operating range/ switching point	Capillary length	Type	Part no.	Price €
Thermostats TRT						
	Changeover contact	0/90 °C	1,000 mm	TRT TR2/711 EU	67216X	
	Changeover contact	0/90 °C	1,500 mm	TRT TR2/711 EU	67217X	
	Changeover contact	10/200 °C	1,000 mm	TRT TR2/712 EU	67609	
	Changeover contact	Stop/310 °C	1,000 mm without jacket	TRT TR2/711 EU	67639	
Safety temperature cut out STB						
	Changeover contact	100 °C	1,000 mm	STB LS1/971 FU	67276X	
	Changeover contact	100 °C	1,500 mm	STB LS1/971 FU	67277X	
	Single	100 °C	1,000 mm	STB LS1/971 F1	67273X	
	Single	90/110 °C	1,000 mm	ETB LS1/961 E1	67619	
	Single	110 °C	1,500 mm	STB LS1/961 F1	67288X	
	Changeover contact	75 °C	1,500 mm	STB LS1/971 FU	67585X	
	Single 0.3 A/100 mV	100 °C	1,500 mm	STW LS3 F1 without manual reset	67312X	
Accessories						
Designation						
Rotary knob 42 mm	---	0/40 °C	---	---	67342	
Rotary knob 42 mm	---	0/90 °C	---	---	67341	
Rotary knob 42 mm	---	0/120 °C	---	---	67343	
Rotary knob 42 mm	---	0/210 °C*	---	---	67344	
Rotary knob 42 mm	---	0/300 °C*	---	---	67345	
Cover for thermostat, black	---	---	---	---	67346	
Cover for thermostat, chrome-plated	---	---	---	---	67347	
Fixing clamp	---	---	---	---	67348	
Press-on spring for pockets	---	---	---	---	67361	

* Minimum order quantity = 100 pieces per delivery.

Pockets for thermometers and thermostats with capillary tube

DG: G, PG: 2

Type	Pocket ½" 7 x 8 mm	Pocket ½" 9 x 10 mm	Pocket ½" 15 x 16 mm	Profile pocket ½" 15 x 16 mm				
Dimensions (mm)								
Connection	½ NPT	½ NPT	½ NPT	½ NPT				
P _{max} *	4 bar	4 bar	4 bar	4 bar				
T _{max} *	200 °C	200 °C	200 °C	200 °C				
Material	Brass/Cu alloy							
Stem length L1	Price € Part no.	PU**	Price € Part no.	PU**	Price € Part no.	PU**	Price € Part no.	PU**
50 mm	67320	200	On request 67326	200	---		---	
100 mm	67321	200	On request 67327	200	67331	200	67335	200
120 mm	67322	200	On request 67328	200	On request 67332	200	On request 67336	200
150 mm	67323	200	67329	200	On request 67333	200	67337	200
200 mm	67324	200	67330	200	67334	200	67338	200
	As above, but nickel-plated							
Stem length L1	Price € Part no.	PU**	Price € Part no.	PU**	Price € Part no.	PU**	Price € Part no.	PU**
100 mm	67321N	200	On request	200	67331N	200	67335N	200
120 mm	On request 67322N	200	On request	200	On request 67332N	200	On request 67336N	200
150 mm	67323N	200	On request	200	67333N	200	67337N	200
200 mm	67324N	200	On request	200	67334N	200	67338N	200

* Applies to static load (load always depends on medium, pressure and temperature of medium, flow rate, installation length and material of thermowell).

** Minimum order quantity manufactured goods = 1 packing unit (PU).

Surface mounting thermostats with housing GAT



- Mechanical temperature controller
- Ideal for underfloor heating systems
- Temperature limitation at pipes
- Easy installation with strap

Application Surface mounting thermostat for strap mounting at pipes from 16 to 100 mm diameter. The version with internal adjustment and temperature control range up to 60 °C is specially suited for underfloor heating systems.

Description The surface mounting thermostat uses a bimetal strip (element consisting of two metal strips with different heat expansion coefficients). When the temperature changes, the bimetal strip bends which triggers electrical switching.

Technical specifications

Type
GAT

Operating range
20/60 °C and 20/90 °C

Tolerance
+2 K/-8 K

Switching differential
 ΔT 8 \pm 3 K

Setting
GAT/7RC: Externally adjustable
GAT/7HC: Internally adjustable

Probe element
Bimetal

Operating temperature range
Housing: Max. 85 °C

Housing

Upper part: Plastic (PVC), grey (RAL 7035)
Base plate: Galvanised sheet steel

Cable entry

Plastic (PVC), black
M20 x 1.5

Degree of protection housing

IP 20 (EN 60529)

Response time

1 K/minute

Electrical switching contact

Changeover contact

Contact rating

NC 16 (2.5) A 250 V AC
NO 2.5 A 250 V AC

Surface mounting thermostats with housing GAT

Housing types and dimensions (mm)

GAT/7RC, external adjustment

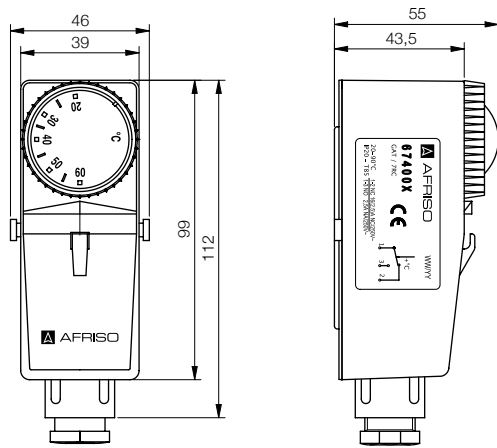

GAT/7HC, internal adjustment

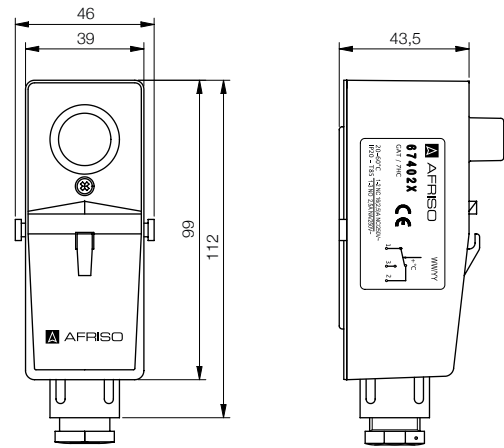

Switching scheme

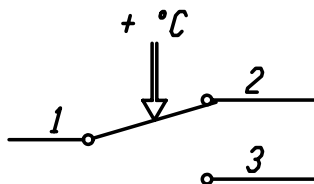

Immersion thermostats with housing GTT



- Mechanical temperature controller
- For controlling heating and cooling processes
- Ideal for heat and process engineering
- Control directly at the process

Application Mechanical temperature controller and limiter. The device is suitable for application areas in the field of heat and process engineering. Heating and cooling processes in industrial or domestic applications can be controlled directly at the process.

Description The temperature measured at the probe causes a change in the volume of the measuring liquid. Electrical switching is triggered by the force acting. The thermowell allows for direct installation pressure-tight tanks.

Technical specifications

Type
GTT / TC2

Operating range
0/90 °C

Tolerance
±1 K at ambient temperature 20 °C

Switching differential
ΔT 4 ±1 K

Setting
GTT/7RG: Externally adjustable
GTT/7HG: Internally adjustable

Probe element
Liquid-filled
Ø 8 mm
Length: 100, 150 or 200 mm

Operating temperature range
Probe: Max. 130 °C
Housing: Max. 85 °C

Process pressure
Max. 4 bar

Probe
Copper

Housing
Plastic (PVC), grey (RAL 7035)

Cable entry
Plastic (PVC), black
M20 x 1.5

Degree of protection housing
IP 40 (EN 60529)

Time constant
DIN-tested
DIN EN 14597:2012-09
Registration number TR/STB 1211

Electrical switching contact
Changeover contact

Contact rating
NC 10 (2.5) A 250 V AC
NO 6 (2.5) A 250 V AC

Options ▪ Customised versions

Immersion thermostats with housing GTT

Housing types and dimensions (mm)

GTT/7RG, external adjustment

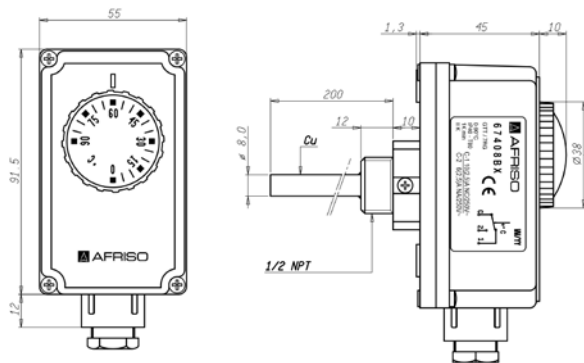

GTT/7HG, internal adjustment

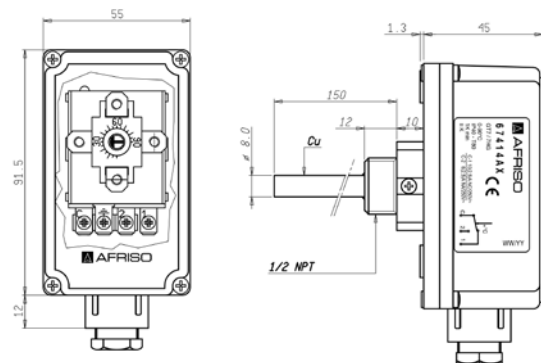

Switching scheme

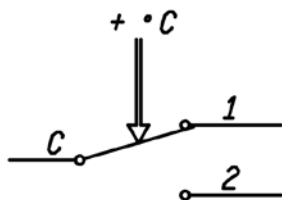

Thermostats with housing GTK with capillary tube



- Mechanical temperature controller for remote measurement
- For controlling heating and cooling processes
- Ideal for heat and process engineering

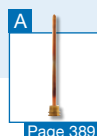

Application Mechanical temperature controller and limiter for remote measurement. The device is suitable for application areas in the field of heat and process engineering. Heating and cooling processes in industrial and domestic applications (in particular solar systems) are easy to control and monitor.

Description The temperature measured at the probe causes a change in the volume of the measuring liquid in the probe-capillary system. Electrical switching is triggered by the force acting. A thermowell allows for pressure-tight installation of the probe in various types of pressurised tanks.

Technical specifications

Type
GTK / TC2

Operating range
0/90 °C

Tolerance
+3 K at ambient temperature 20 °C

Switching differential
 ΔT 4 \pm 1 K

Setting
Externally adjustable

Probe element
Liquid-filled
 \varnothing 6.5 x 95 mm

Operating temperature range
Probe: Max. 150 °C
Housing: Max. 80 °C

Probe
Copper

Housing
Plastic (PVC), grey (RAL 7035)

Cable entry
Plastic (PVC), black
M20 x 1.5

Capillary length
Cu capillary tube with PVC coating, black
L = 1,000, 2,000 mm

Degree of protection housing
IP 40 (EN 60529)

Time constant
DIN-tested
DIN EN 14597:2012-09
Registration number TR/STB 1211

Electrical switching contact
Changeover contact

Contact rating
NC 10 (2.5) A 250 V AC
NO 6 (2.5) A 250 V AC

Options ▪ Customised versions

Thermostats with housing GTK with capillary tube

Housing types and dimensions (mm)

GTK/7RD, external adjustment

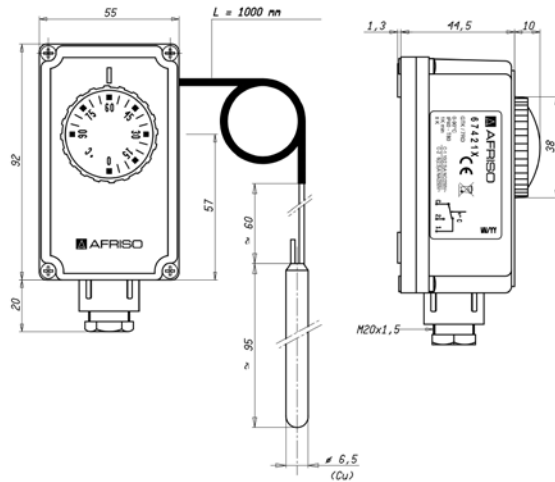

Switching scheme

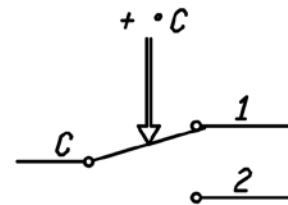

Room thermostats with housing GRT



- Mechanical temperature controller
- For monitoring of greenhouses
- For use in animal breeding applications
- Easy wall mounting



Bottom connection version

Application Mechanical room thermostat for industrial use. Due to the high degree of protection, the device can be used in humid rooms and in animal breeding applications. The room thermostats are also suitable for temperature monitoring in greenhouses.

Description The temperature measured at the probe causes a change in the volume of the measuring liquid. Electrical switching is triggered by the force acting.

Technical specifications

Type
GRT

Operating range
0/40 °C and 0/55 °C

Tolerance
+2 K at ambient temperature 20 °C

Switching differential
0/40 °C ΔT 2 \pm 1 K
0/55 °C ΔT 3 \pm 1 K

Setting
GRT/7RT: Externally adjustable
GRT/7HT: Internally adjustable

Probe element
Liquid-filled

Operating temperature range
Probe: 0/40 °C 50 °C
Housing: 0/55 °C 85 °C

Probe
Copper, nickel-plated

Housing
Plastic (PVC), grey (RAL 7035)

Cable entry
Plastic (PVC), black
M16 x 1.5

Degree of protection housing
IP 54 (EN 60529)

Electrical switching contact
Changeover contact

Contact rating
NC 16 (2.5) A 250 V AC
NO 6 (2.5) A 250 V AC

Room thermostats with housing GRT

Housing types and dimensions (mm)

GRT/7RT, external adjustment

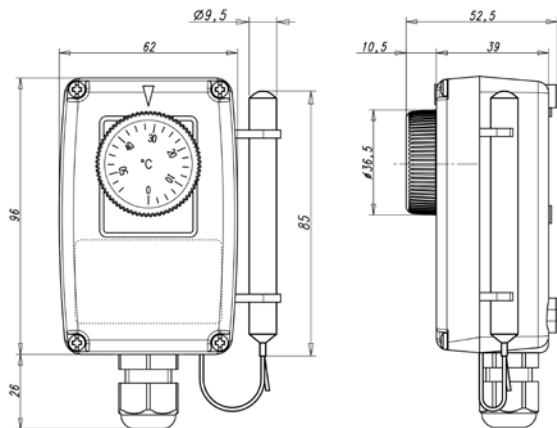

GRT/7HT, internal adjustment

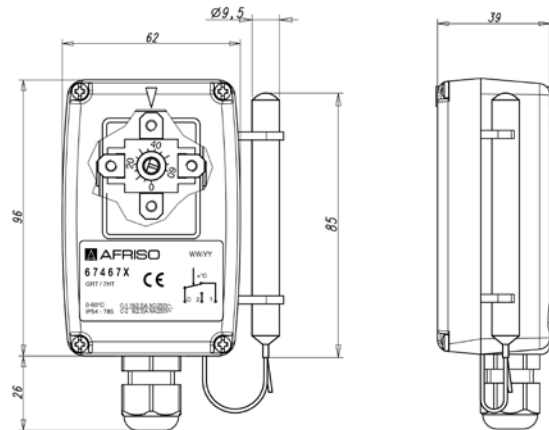

GRT/7HT, radial, internal adjustment

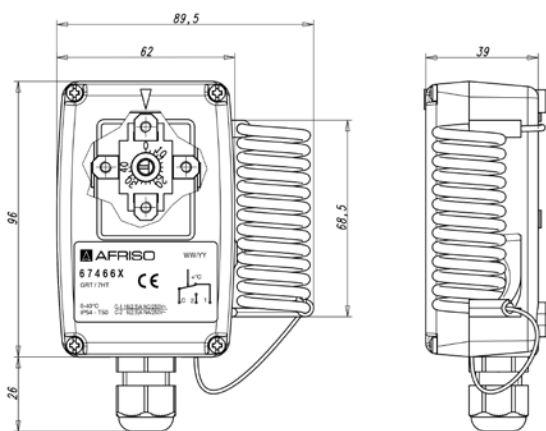

Switching scheme

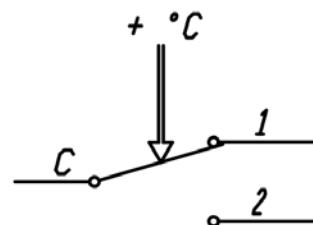

Twin thermostats with housing GDT



- Mechanical temperature controller
- Ideal for all heat and process engineering applications
- With integrated safety temperature cut out
- Control directly at the process



Version TRT/STB with reset button

Application Twin thermostat with housing with pocket. Available with two temperature control thermostats (TRT) for controlling heating and cooling processes in industrial and domestic applications. Also available as version with temperature control thermostat (TRT) and safety temperature cut out (STB) with manual reset button. The device is suitable for application areas in the field of heat and process engineering.

Description The temperature measured at the probe causes a change in the volume of the measuring liquid. Electrical switching is triggered by the force acting. The thermowell allows for direct installation pressure-tight tanks.

Technical specifications

Type

GDT / TLSC

Operating range/switching point

TRT: 0/90 °C – 0/90 °C

STB: 100 °C

Tolerance

STB: +0 K/-6 K at ambient temperature 20 °C

TRT: +/- 3 K

Switching differential

 ΔT 4 ±1 K

Setting

TRT externally or internally adjustable

Probe element

Liquid-filled

Ø 16 mm, profile pocket

Length 100

Operating temperature range

Probe: Max. 125 °C

Housing: Max. 80 °C

Process pressure

Max. 4 bar

Probe

Copper

Housing

Plastic (PVC), grey (RAL 7035)

Cable entry

Plastic (PVC), black

M20 x 1.5

Degree of protection housing

IP 40 (EN 60529)

Time constant

DIN-tested

DIN EN 14597:2012-09

Registration number TR/STB 1231

Electrical switching contact

2 x changeover contact

Contact rating

TRT

NC 10 (2.5) A 250 V AC

NO 6 (2.5) A 250 V AC

STB

NC 10 (2.5) A 250 V AC

NO 10 (2.5) A 250 V AC

Twin thermostats with housing GDT

Housing types and dimensions (mm)

GDT/8RS, version TRT/STB

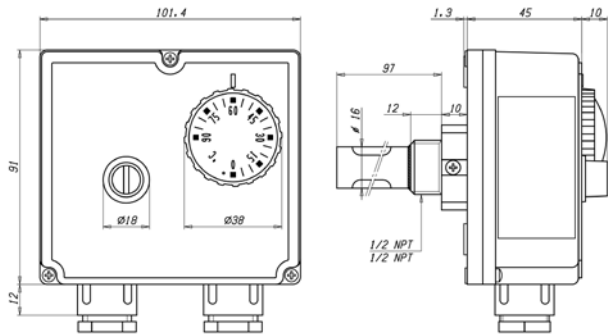

Switching scheme

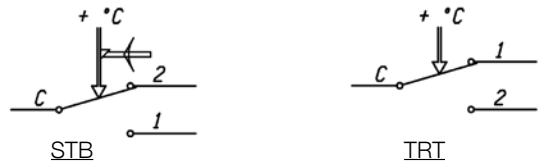

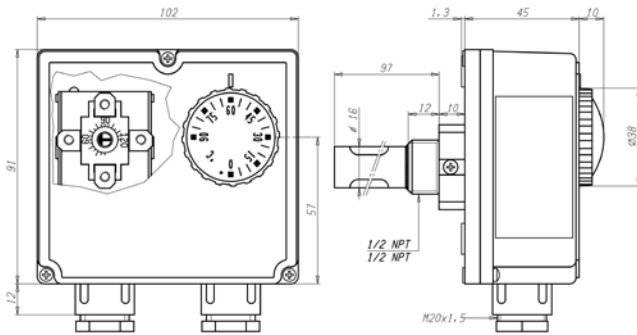

GDT/8HR, version TRT/TRT

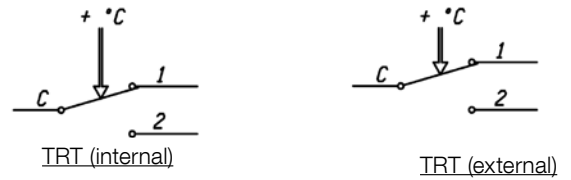

Switching scheme

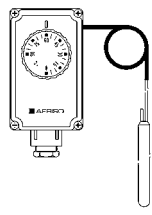
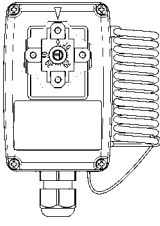
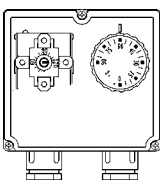

Thermostats with housing

DG: G, PG: 4	Adjustment	Operating range/ switching point	Capillary length	Stem length	Type	Part no.	Price €
Surface mounting thermostats with housing							
	External	20/60 °C	---	---	GAT/7RC	67400X	
	External	20/90 °C	---	---	GAT/7RC	67401X	
	Internal	20/60 °C	---	---	GAT/7HC	67402X	
	Internal	20/90 °C	---	---	GAT/7HC	67403X	
Immersion thermostats with housing							
	External	0/90 °C	---	100 mm	GTT/7RG	67407X	
	External	70/210 °C	---	100 mm	GTT/7RG	67708	
	External	0/90 °C	---	150 mm	GTT/7RG	67408AX	
	External	0/90 °C	---	200 mm	GTT/7RG	67408BX	
	Internal	0/90 °C	---	100 mm	GTT/7HG	67413X	
	Internal	0/90 °C	---	200 mm	GTT/7HG	67414BX	
Capillary type thermostats with housing/room thermostats with housing							
	External	0/90 °C	1,000 mm	---	GTK/7RD	67421X	
	External	0/90 °C	2,000 mm	---	GTK/7RD	67424X	
	External	0/40 °C	---	---	GRT/7RT	67464X	
	External	0/55 °C	---	---	GRT/7RT	67465X	
	Internal	0/40 °C	---	---	GRT/7HT	67466X	
	Internal	0/55 °C	---	---	GRT/7HT	67467X	
Twin thermostats with housing							
	Internal/external	0/90 °C - 0/90 °C	---	100 mm	GDT/8HR	67447X	
	Fixed/external	0/90 °C (100 °C)	---	100 mm	GDT/8RS	67453X	
	Internal/external	0/60 °C - 30/120 °C	---	280 mm	GDT-TTCA	67640	

* Minimum order quantity for non-stock items = 5 pieces.

Resistance thermometers

WTh 20/21



WTh 20

Technical specifications

Version
Plug-in type resistance thermometer

Sensor
1 x Pt 100
2-, 3- or 4-wire
Class B, IEC 751

Probe
Ø 6 mm, length 50 mm
Stainless steel 316 Ti

Electrical connection
Cable with wire ferrules

Cable
PVC (heat-resistant)

Measuring range
With installation type
Fixed: -40/+105 °C
Moving: -5/+105 °C

- Options**
- Coated measuring line
 - Sensor class A
 - Sensor PT 1,000
 - Process connection as adjustable compression fitting or fixed male connection
 - Connector ISO 4400
 - Miniature circular plug
 - Lemossa connector
 - Other probe diameters
 - Other probe lengths
 - Other cables:
 - Silicone (-50/+180 °C)
 - PTFE (-200/+260 °C)
 - Glass fibre with stainless steel braiding (-50/+400 °C)
 - Bending protection



WTh 21

Version
Indoor and outdoor resistance thermometer for wall mounting

Sensor
1 x Pt 100
2-, 3- or 4-wire
Class B, IEC 751

Probe
Ø 6 mm, length 42 mm
Stainless steel 316 Ti

Electrical connection
Cable gland

Measuring range
-50/+90 °C

Housing
Impact-resistant plastic
W x H x D 58 x 64 x 36 mm

Degree of protection
IP 65 (EN 60529)

- Open probe
- Sensor class A
- Sensor PT 1.000/Ni 1.000

Resistance thermometers

WTh 22/23



WTh 22

Description **Version**
Resistance thermometer especially for use in air ducts

Technical specifications **Sensor**
1 x Pt 100
2-, 3- or 4-wire
Class B, IEC 751

Probe
Ø 8 x 1 mm, perforated
Stainless steel 316 Ti

Process connection
Mounting flange Ø 40 mm,
adjustable, stainless steel

Installation lengths
100, 160, 250 mm

Housing
Impact-resistant plastic
W x H x D 58 x 64 x 36 mm

Degree of protection
IP 54 (EN 60529)

Measuring range
0/130 °C

- Options**
- Process connection G $\frac{1}{2}$ B (compression fitting or fixed male connection)
 - Sensor class A
 - Sensor PT 1,000
 - Transmitter installation (standard: 0/100 °C = 4–20 mA)



WTh 23

Version
Compact screw-in resistance thermometer specially for heating, ventilation and air conditioning applications

Sensor
1 x Pt 100
2-, 3- or 4-wire
Class B, IEC 751

Measuring insert
Not replaceable

Protective pipe
Ø 6 mm, stainless steel 316 Ti

Process connection
G $\frac{1}{4}$ B stainless steel 316 Ti

Installation length
100 mm

Connection head (degree of protection)
Type J, aluminium die cast (IP 54)

Measuring range
-35/+180 °C

- Sensor class A
- Sensor PT 1,000
- Transmitter installation
- Other thermowell diameters
- Thermowell with bend, measuring tip with spring
- Neck
- Other process connections
- Other installation lengths

Resistance thermometers types WTh 20/21/22/23

Dimensions (mm)

Type WTh 20

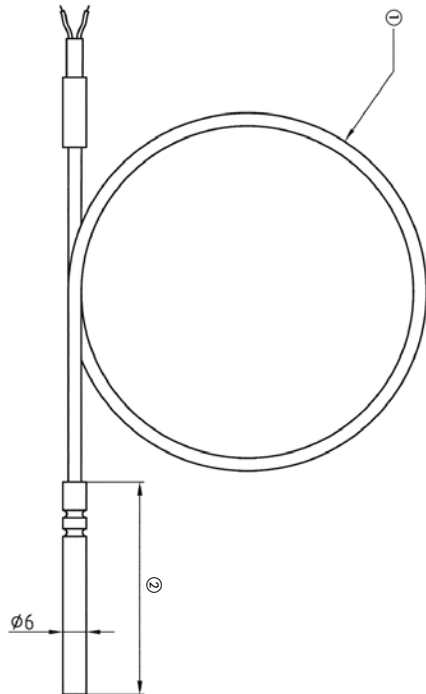

- ① Cable
- ② Probe length

Type WTh 21

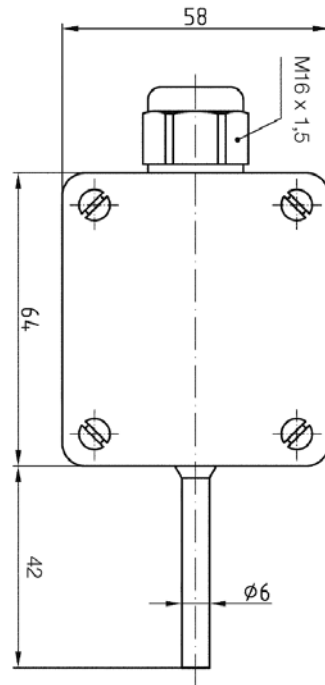

Type WTh 22

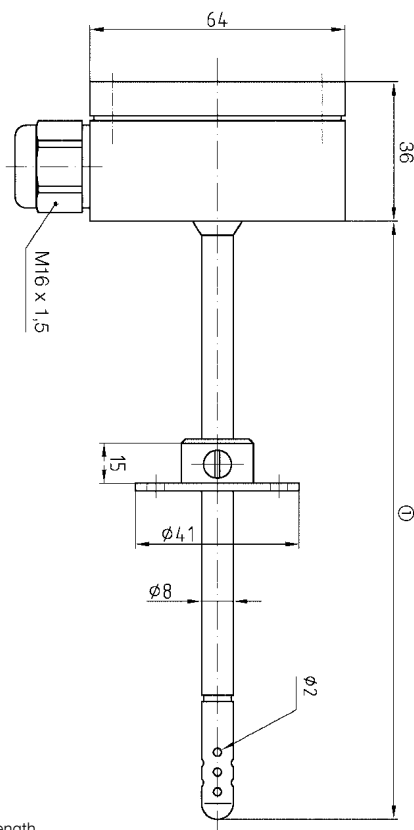

- ① Installation length

Type WTh 23

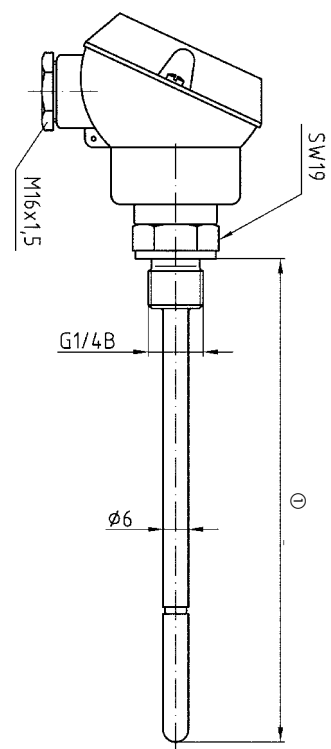

- ① Installation length

Resistance thermometers

DG: H, PG: 4

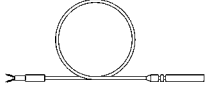
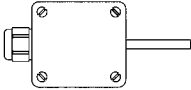
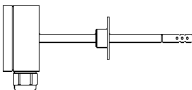
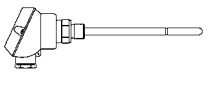
Type	WTh 20	WTh 21	WTh 22	WTh 23	
Version					
Sensor	1 x Pt 100 3-wire, class B	1 x Pt 100 3-wire, class B	1 x Pt 100 3-wire, class B	1 x Pt 100 3-wire, class B	
Thermowell/probe diameter Material	6 mm Stainless steel 316 Ti	6 mm Stainless steel 316 Ti	Perforated 8 mm Stainless steel 316 Ti	6 mm Stainless steel 316 Ti	
Neck	---	---	---	---	
Process connection	---	---	Mounting flange Ø 40 mm	G1/4B Stainless steel 316 Ti	
Connection head / electrical connection	PVC cable Wire ferrules	Plastic/cable gland	Plastic/cable gland	Type J/cable gland	
Measuring range fixed (moving)	-40/+105 °C (-5/+105 °C)	-50/+90 °C	0/130 °C	-35/+180 °C	
Installation length	Price € Part no.	Price € Part no.	Price € Part no.	Price € Part no.	
44 mm	Probe length 50 mm Up to cable length 2,000 mm	32400	---	---	
100 mm		---	32215	32225	
160 mm		32220	---	32216	32226
250 mm		Cable extension per 500 mm	---	32217	32227
400 mm			---	---	32228
Extra charges (without PG)	Price €	Price €	Price €	Price €	
Per additional 100 mm** installation length	---	---	---	---	
1 x Pt 100 4-wire					
2 x Pt 100 2-wire	---	---	---		
Sensor class A					
Connection head Type BBK	---	---			
Transmitter installation* DC 7.5–30 V/4–20 mA	---				

* Applies to standard measuring ranges (-50/+50, 0/50, 0/100, 0/120, 0/150, 0/200, 0/300 °C), extra charge in all other cases €.

** Applies up to 1000 mm, one-time extra charge for installation length greater than 1000 mm: €.

i

See the catalogue
Industrial Technology
for additional resist-
ance thermometers.

CATALOGUE INDUSTRIAL TECHNOLOGY

Temperature measuring instruments and controllers for industrial technology



Bimetal stainless steel thermometers

- + For corrosive media
- + Pointer adjustable in case of "plain" connection

Nominal sizes
63 – 80 – 100

Ranges
-20/+60, 0/60, 0/120, 0/160 °C



Page 269



Bimetal thermometers for chemical applications

- + For chemical, process engineering and food industry applications
- + Many options for adaptation to specific applications

Nominal sizes
63 – 80 – 100

Ranges
-20/+60, 0/60, 0/120, 0/160 °C



Page 269



Gas filled thermometers

- + For chemical, process engineering and food industry applications
- + Fast response

Nominal sizes
100 – 160

Ranges
-20/+60, 0/60, 0/120, 0/160,
0/200, 0/300, 0/400, 0/500 °C



Page 274



Resistance thermometers WTh 24-28

- + Versions for machine and plant engineering, food, beverages and pharmaceutical industries, biotechnology
- + For medium to high pressure and flow loads
- + Pt-100 sensor
- + Installation length up to 400 mm

Measuring ranges
-35/+400, -35/+300,
-35/+550 °C



From page 284



Resistance thermometers WTh 30

- + Hygienic design as per EHEDG recommendations
- + Various process connections, transducer can be integrated
- + Pt-100 sensor
- + Installation length up to 200 mm

Measuring ranges
-50/+200 °C



From page 291



This and many other products can be found in the catalogue INDUSTRIAL TECHNOLOGY.

The BlueLine measuring instrument series at a glance



	BLUELYZER ST	EUROLYZER STx	MULTILYZER STx	STM 225 – BLACK EDITION	Series S4600 ST
O ₂	•	•	•		
CO (up to 6,000 ppm)	•				
CO (up to 10,000 ppm)		•	•		
CO ₂ (calculated)	•	•	•		
NO		•***	•***		
NO ₂			•***		
NO _x		•***	•***		
CO (40,000 ppm)			•***		
SO ₂			•***		
Particulate matter				•	
Methane					
Propane (liquefied gas)					
Butane					
Lambda	•	•	•		
Eta efficiency / eta coefficient	•	•	•		
Flue gas loss qA	•	•	•		
Temperature	•	•	•		
Pressure	•	•	•		•
Dew point	•	•	•		
Humidity in %					
Volume flow		•***	•***		•***
Measurements of filters, ventilation systems, ducts					•
Measurements of production facilities, tanks					•
Burner servicing (gas, oil, solid fuel systems)	•	•	•	•	•
CO ambient measurement	•	•	•		
Servicing of water heaters	•	•	•		
Servicing of CHP systems		•	•		
Flue gas measurement	•	•	•		
Pressure measurement	•	•	•		•
Measurement of inlet pressure, flow pressure, static pressure, nozzle pressure		•	•		•
Pressure / vacuum measurement	•	•	•		•
Differential pressure measurement		•	•		•
Vacuum measurement					•
Temperature measurement (flue gas, air, external wall)	•	•	•		
Temperature measurement (water)					
Temperature measurement (moving objects)					
Surface temperature measurement	•	•	•		
Differential temperature measurement	•	•	•		
Draft/chimney draft measurement	•	•	•		•
Ventilation loss measurement					
Flue gas loss measurement	•	•	•		
Heating system check					
4 Pa test					
Gas leak detection					
Gas concentration measurement					
Flow rate measurement (water)					
Moisture measurement (material/moisture/indoor climate)					
Air velocity		•***	•***		•***
BlmSchV		•	•		
EN 50379-2		•	•		•
EN 15378					
KÜO		•	•		

Parameters/measured values

Typical applications areas

Approvals

📄 Page 14

📄 Page 16

📄 Page 18

📄 Page 20

📄 Page 32

* See product description on the catalogue page or in the operating instructions.
 ** Depends on product version.
 *** Optional.

Innovative. Future proof. Simply powerful.

From a simple measuring instrument to an all-rounder with CAPBs®

You already own an AFRISO BlueLine measuring instrument* and want to use it for the majority of your daily measuring tasks, for example, tightness test, gas leak detection, flow rate measurement or 4 Pa test? No problem with your AFRISO measuring instrument. In conjunction with the AFRISO CAPBs® base handle BG 10 and the sensor modules for a whole variety of different applications such as pressure, temperature, gas leak detection or humidity, almost all tasks of heating system technicians and chimney sweeps can be performed easily and with

high accuracy. The compact CAPBs® can be connected wirelessly via Bluetooth® Low Energy to the measuring instruments of the AFRISO BlueLine series* or to mobile devices. The new CAPBs® device displays the determined value on the display in real-time and provides a QR code for mobile devices for data transmission. All measurement data can be further processed with the AFRISO apps on the smartphone or tablet and saved as clearly structured PDF records.

12



 See pages 410–415 for detailed information on the available CAPBs®.

The CAPBs® excel with an unprecedented diversity of measuring possibilities with a single system. Numerous sensor modules CAPBs® sens can be easily plugged into the modular base handles. The ergonomic handles themselves are made of high-quality plastic. The compact base handle BG 10, for example, contains the power supply (battery, optionally rechargeable), a tripod socket, a multi-purpose key and a multi-colour LED. The multi-purpose key features customisable function assignments. For example, it can be used for zero calibration regardless of the

measuring site. In addition, a device for audible signals is integrated into the handle. The AFRISO measuring instrument or the apps for smartphone and tablet provide numerous pre-installed measurement menus for the CAPBs®. They include, for example, tightness test and load test, pressure loss measurement, gas leak detection, heating system check, hydraulic balancing, thermal disinfection, etc.

 Bluetooth®



12







 The following measuring instruments can be immediately used with a sensor module and the base handle CAPBs® BG 10:

* BLUELYZER ST, EUROLYZER STx, MULTIPLYZER STe/STx, pressure measuring instrument series S4600 ST and temperature measuring instrument TMD 9.

CAPBs® sensor modules for pressure measurement and tightness test

							
		Pressure measurement	Pressure measurement	Pressure measurement	Pressure measurement	Pressure measurement	Pressure transmitter
CAPBs®		PS 10 (20 mbar)	PS 20 (180 mbar)	PS 33 (2 bar)	PS 40/41 (6 bar)	PS 60/61 (20 bar)	PT 70 (25 bar)
Application examples		Measurement of ultra-fine pressure (Pitot measurement)	Check of connection and flow pressure in gas-fired heating systems	Evaluation of serviceability (TRGI)	Tightness and load test of gas lines	Stress pressure test at pipe systems	Test of water pipes (test medium water) as per ZVSHK
Temperature	Parameters/measured values						
Pressure		•	•	•	•	•	•
Dew point							
Volume flow		•*	•*				
Measurements of filters, ventilation systems, ducts	Typical applications areas		•	•	•	•	
Measurements of production facilities, tanks, gas pipes			•	•	•	•	•
Burner adjustment/servicing (gas, oil, solid fuel systems)		•	•	•	•		
Pressure measurement		•	•	•	•	•	•
Tightness test (gas)			•	•	•		
Load test (gas)				•	•		
Serviceability test (gas)				•	•		
Tightness test (ZVSHK)			•**	•	•**	•**	•***
Strength test (ZVSHK)				•	•	•**	•***
Stress pressure test						•	•
Measurement of inlet pressure, flow pressure, static pressure, nozzle pressure				•		•	
Pressure / vacuum measurement		•	•		•	•	•
Differential pressure measurement		•	•				
Vacuum measurement		•	•		•	•	
Surface temperature measurement							
Draft/chimney draft measurement		•	•				
Ventilation loss measurement							
Heating system check							
4 Pa test							
Air velocity		•*	•*				
		 Page 66	 Page 66	 Page 66	 Page 66	 Page 66	 Page 66

* Accessories required, see catalogue page.
 ** With test medium air.
 *** With test medium water.

						
Pressure/ temperature	Tightness test	Evaluation of serviceability	Tightness test underfloor heating system	Tightness test water pipe	Test set	Test set
FP 10	DPK 60-6 sens	DPK 60-7 sens	PT 70 - FBH	ADS-WS	Heating system check 2.0	4 Pa test
Determination of ventilation loss (heating system check), 4 Pa test	Leak test set for gas, heating, oil or water pipes	Evaluation of serviceability of gas lines (TRGI)	Leak test set for underfloor systems for heating/cooling	Pressure tests at (drinking) water pipes	Determination of ventilation loss	Check of under- pressure values in buildings
•					•	
•	•	•	•	•	•	•
•					•	
	•	•		•		•
•	•	•	•	•	•	•
	•	•				
		Only with BG 10				
	•	•		•		
	•			•		
	•	•				
	•	•				
•					•	•
•	•	•	•	•	•	•
•					•	•
•						
•					Only with BG 10	
•					Only with BG 10	
•						•
•					•	•
Page 69	Page 78	Page 79	Page 80	Page 81	Page 81	Page 82

CAPBs® sensor modules – further application areas



	Temperature	Temperature	Humidity/ air temperature	Air quality	Air quality	Air quality
CAPBs®	TK 10/11 type K	TK 20 – TK 50	RH 80	AQ 20	AQ 35	AQ 36
Application examples	Determination of temperatures on surfaces, in liquids and in gases	Determination of temperatures on surfaces, in liquids and in gases	Monitoring or humidity in closed rooms	Fast and reliable detection of VOCs (volatile organic compounds) and CO ₂	Detection of CO ₂	Detection of CO ₂ , humidity and temperature
Methane						
Propane (liquefied gas)						
Butane						
Temperature	•	•	•			•
Pressure						
Humidity in %			•			•
CO						
CO ₂				•	•	•
VOC				•		
Volume flow						
TDS value in mg/l						
Salinity						
Electrical conductivity						
pH value						
Flow rate measurement (water)						
Thermal disinfection						
Measurements of filters, ventilation systems, ducts				•	•	•
Adjustment of ventilation/air conditioning systems (EN 16798/TRGS 900)			•	•	•	•
Measurements of production facilities, tanks, gas pipes						
Heating water analysis (VDI 2035)						
Drinking water analysis (rapid test)						
Burner adjustment/servicing (gas, oil, solid fuel systems)						
Hydraulic Balancing						
Servicing of water heaters	•	•				
Temperature measurement (flue gas, air, external wall)	•	•				
Temperature measurement (water)	•	•				
Surface temperature measurement						
Gas leak detection						
Gas concentration measurement						
Moisture measurement (material/moisture/indoor climate/mould)			•			
Air velocity						
	Page 70	Page 71	Page 72	Page 72	Page 73	Page 73

* Accessories required, see catalogue page.
 ** With test medium air.
 *** With test medium water.

Welcome to the future.

Cutting edge measuring technology – AFRISO CAPBs® measuring units.

+ Comprehensive

Easy extension of BlueLine measuring instruments* by a great variety of applications such as pressure measurement, temperature measurement, humidity measurement, volume flow or Pitot measurement as well as gas leak detection, flow measurement, hydraulic balancing, etc.

+ Wireless

Wireless, immediate transmission of the measurement data to your AFRISO measuring instrument, smartphone or tablet with Bluetooth® Low Energy technology.

+ Flexible

Base handle BG 10 with multi-purpose key with customisable function assignment for ease of use and consistent operation of the CAPBs®, regardless of site.

+ Accurate

Position-independent, temperature-compensated sensor technology for maximum precision in all measuring scenarios.

+ Modular

Numerous, versatile applications thanks to modular design with universal base handle for all sensor modules.

+ Universal

Compatible with our proven BlueLine measuring instruments* or your smartphone and tablet.



i The following measuring instruments can be immediately used with a sensor module and the base handle CAPBs® BG 10:

* BLUELYZER ST, EUROLYZER STx, MULTILYZER STe/STx, pressure measuring instrument series S4600 ST and temperature measuring instrument TMD 9.

+ Proven

Easy documentation of measurement results on site via IR or Bluetooth® Low Energy interface of the BlueLine measuring instrument.

+ Focused

Measurement data centre for saving the measurement results in the BlueLine measuring instrument or the app. Optional data logger function for data output in XML format for flexible further processing with standard software applications such as MS Excel.

+ Error-free

Simultaneous storage of all measured data to the measuring instrument or the mobile devices helps to avoid errors, for example caused by incorrect readings.

Bluetooth®



EuroSoft live app



AFRISO TOOLBOX App



+ Ergonomic

Light-weight, ergonomic handle made of robust, high-quality plastic with three integrated magnet for hands-free operation.

+ Ready for measurement

Free firmware update for BlueLine measuring instruments* with pre-installed measurement menus for all available CAPBs® – can be done by the user at any time via the microSD card.

+ Independent

Free app for EuroSoft live for operation of all CAPBs® via smartphone and tablet. With pre-installed measurement menus for special applications (for example, gas line checks) and graphical representation of the measurement results.

+ Quality

100 % made in Germany.

+ Energy-saving

Automatic switching off of the CAPBs® when the Bluetooth® Low Energy connection is closed ensures low energy consumption.

+ Revolutionary

Continuous, simultaneous flow and temperature measurement in water applications with the new, TÜV-tested flow rate/temperature measuring instrument FlowTemp® STx.

Further information:





Appendix – Technical Information

SERVICE

Seminars and training	418
AFRISO services	419
Information material – brochures, flyers	420
Downloads	421
AFRISO specialised company search	422

CERTIFICATES

ISO 9001, ISO 14001, ATEX, Pressure Equipment Directive 2014/68/EU	423
PROOFED BARRIER, redden, DNV-GL	424

TECHNICAL INFORMATION

Flange standard EN 1092 International comparison of grades	425
Conversion table pressure units	426
Pressure Equipment Directive 2014/68/EU (PED)	427
Selection criteria/safety considerations for pressure gauges as per EN 837-2	428

CHECK LISTS

Enquiry level measurement	430
Enquiry – thermometers	431
Enquiry – resistance thermometers	432
Enquiry – pressure gauges	433

TEST REPORTS

Level sensor chain	434
Liquid-based leak detector LAS	435
Liquid-based leak detector LAG	436
Vacuum type leak detectors	437
Pressure type leak detectors	438
Protection equipment against siphoning	439

GENERAL TERMS OF DELIVERY / INDEX

General Terms of Delivery	440
Index	445

Seminars and Training

Professional and practical. With our courses, workshops and seminars, you benefit from our many years of in-depth experience in the field of measuring and control technology. Our entire offering responds to current topics and standards as well as customer requirements. Of course, it is also possible to arrange for individual in-house courses and seminars to be provided at your site.



AFRISO training programme

Smart home expert
One-day training seminars to provide an overview of and structure an AFRISO smart home system

Tank protection and leak protection lining
Two-day seminar on the installation of leak protection linings and leak detectors (theory and practice)

Fuel oil consuming system current status
One-day seminar on planning, modernising and converting heating oil supply systems

Hydraulic Balancing
One-day seminar on hydraulic balancing with the VarioQ valve program with measuring function

Heating system check as per EN 15378
One-day seminar on the inspection and evaluation of heating systems

HVAC service with BlueLine, CAPBs® and apps
One-day seminar on the typical measuring tasks of HVAC professionals

Dust measurement at solid-fuel systems
One-day seminar on working with the dust measuring instrument STM 225 BLACK EDITION (theory and practice)

13

i
We will be glad to answer your questions concerning our seminars. Please get in touch with us.
E-mail: training@afriso.de
Phone: +49-7135-102-222



Visit us at www.afriso.com/training for our full training programme and additional information.

Our Service – Your Benefit

Flexible, cost-aware, on schedule, solution-orientated and fast – the AFRISO team always provides the decisive added value.



Information and presentation

Whether telephone support or on site: Our consultants speak your language – we provide you with personal and individual consulting worldwide. And if you have an in-house event for your customers, we will be glad to participate.

After sales service

Whether commissioning, professional maintenance, calibration or function checks – a network of service centres and our specialists in the plant support you in getting the maximum out of your AFRISO product. For safe processes, precise measurement results, compliance with legal requirements and a long service life.

Repair service

In the case of a malfunction, request a return slip at service@afriSO.de and send us your AFRISO device along with a short description of the problem. We will deal with your request within a few workdays.

Rental devices

You cannot afford to do without your instrument? No problem, our rental service ensures that you remain on duty. When you send your device for maintenance or repair, you can indicate if you are interested in a rental device. We will immediately get in touch with you.

13

i

Our service department will be glad to answer your questions.
Please get in touch with us.
Phone: +49 7135 102-211

AFRISO information material – brochures and flyers

Discover new opportunities and sales potential with AFRISO quality products. We offer a large variety of information materials and media for wholesalers, points of sale, associations, HVAC companies and tank protection companies. You can order these media from us free of charge – even large numbers of copies. All printed materials allow you to add your company stamp to the back page.

Flyers, brochures and product overviews

Flyers, brochures, and product overviews provide information on individual products or complete product ranges for various application areas.



Product literature for end consumers

Product literature for end users is a great medium for fairs, exhibition rooms, mail campaigns and other activities. They present the benefits and applications of AFRISO products for building technology and tank protection in private households in a concise, easy-to-understand way.



i

All information material can be downloaded from the download centre at www.afriso.com. If you want to order for free, simply specify the number of copies required in your e-mail to marketing@afriso.de.

Downloads

On www.afriso.com, you can find all product-relevant information such as operating instructions, brochures, special forms, certificates, CAD files or suitable software directly on the product page under Downloads.

Visit the INFO CENTRE on www.afriso.com for comprehensive information, technical specifications, terms and conditions, valuable downloads and the latest news – all around the clock.

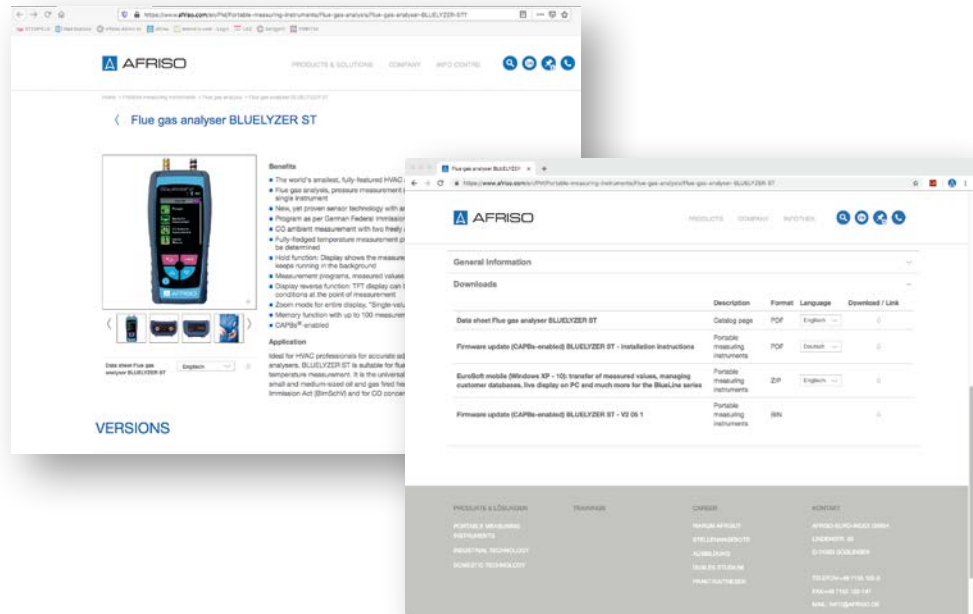

Operating instructions

In addition to product descriptions, the operating instructions include detailed technical specifications, mounting, installation and safety information as well as information on approvals for all AFRISO products.

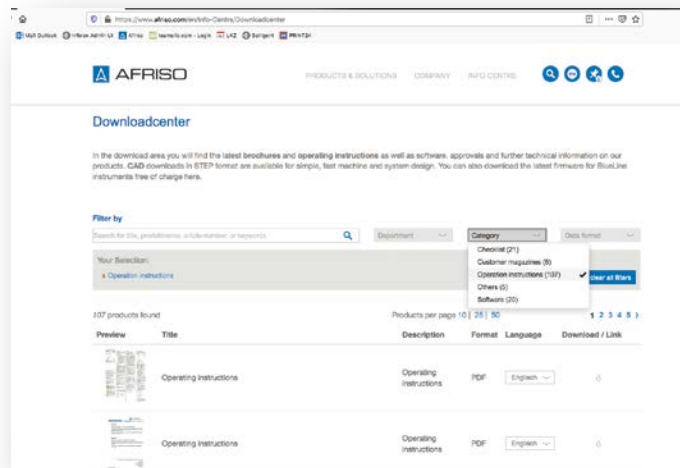

Software

Due to continuous improvements and to changes in legislation and directives, we provide software updates for electronic measuring instruments on an ongoing basis. The updates and the appropriate instructions can be downloaded from our website for free.

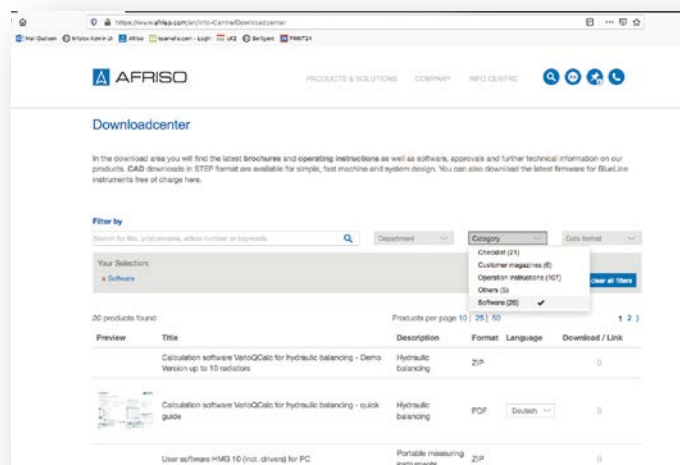

Certificates and approvals

You can find the latest certificates at www.afriso.com directly on the respective product page.



ZERTIFIKAT

Die Zertifizierungsstelle der TÜV SÜD Management Service GmbH bescheinigt, dass das Unternehmen

AFRISO-EURO-INDEX GmbH
Lindenstr. 20, 74363 Güglingen
Deutschland
Friedhofstr. 3, 63916 Amorbach
Deutschland

für den Geltungsbereich

Entwicklung, Produktion und Vertrieb von Mess-, Regel- und Überwachungsgeräten für die Haustechnik, Industrie und Umweltschutz

ein Qualitätsmanagementsystem eingeführt hat und anwendet.

Durch ein Audit, Auftrags-Nr. 70010777, wurde der Nachweis erbracht, dass die Forderungen der

ISO 9001:2015

erfüllt sind.

Dieses Zertifikat ist gültig vom 03.08.2019 bis 02.08.2022.
Zertifikat-Registrier-Nr.: 12 100 14587 TMS.





Product Compliance Management
München, 14.05.2019

TÜV SÜD Management Service GmbH • Zertifizierungsstelle • Riederstrasse 57 • 80339 München • Germany
www.tuv-sud.de/certificate-validity-check





ZERTIFIKAT

Die Zertifizierungsstelle der TÜV SÜD Management Service GmbH bescheinigt, dass das Unternehmen

AFRISO-EURO-INDEX GmbH
Lindenstr. 20, 74363 Güglingen
Deutschland
Friedhofstr. 3, 63916 Amorbach
Deutschland

für den Geltungsbereich

Entwicklung, Produktion und Vertrieb von Mess-, Regel- und Überwachungsgeräten für die Haustechnik, Industrie und Umweltschutz

ein Umweltmanagementsystem eingeführt hat und anwendet.

Durch ein Audit, Auftrags-Nr. 70010777, wurde der Nachweis erbracht, dass die Forderungen der

ISO 14001:2015

erfüllt sind.

Dieses Zertifikat ist gültig vom 03.08.2019 bis 02.08.2022.
Zertifikat-Registrier-Nr.: 12 104 14587 TMS.





Product Compliance Management
München, 14.05.2019

TÜV SÜD Management Service GmbH • Zertifizierungsstelle • Riederstrasse 57 • 80339 München • Germany
www.tuv-sud.de/certificate-validity-check





Mitteilung über die Qualitätssicherung Produktion

Nr. EX2A 015639 0016 Rev. 00

Zertifikatsinhaber: AFRISO-EURO-INDEX GmbH
Lindenstr. 20
74363 Güglingen
DEUTSCHLAND

Betriebsstätte(n): AFRISO-EURO-INDEX GmbH
Lindenstr. 20, 74363 Güglingen, DEUTSCHLAND

Geltungsbereich:  Elektrische Betriebsmittel in den Zündschutzarten Eigenherstellung : Zündschutzart "I" Handelsware/Zweitschein: Zündschutzart "I"

Die Zertifizierungsstelle der TÜV SÜD Product Service GmbH bescheinigt mit diesem Zertifikat, dass das oben genannte Unternehmen ein Qualitätssicherungssystem anwendet, das den Anforderungen gemäß Anhang IV der Richtlinie Nr. 2014/34/EU für Geräte und Schutzsysteme zur bestimmungsgemäßen Verwendung in explosionsgefährdeten Bereichen (ATEX) entspricht. Die Gültigkeit dieses Zertifikates setzt eine regelmäßige Überwachung voraus. Umseitige Hinweise sind zu beachten.

Bericht Nr.: 713142199
Gültig bis: 2021-10-31

(Klaus Lorenz)

Datum, 2018-12-21

Seite 1 von 1
TÜV SÜD Product Service GmbH ist notifizierte Stelle gemäß der Richtlinie Nr. 2014/34/EU für Geräte und Schutzsysteme zur bestimmungsgemäßen Verwendung in explosionsgefährdeten Bereichen mit der Kennnummer 0123.

TÜV SÜD Product Service GmbH • Zertifizierungsstelle • Riederstraße 65 • 80339 München • Deutschland





ZERTIFIKAT

Die Notifizierte Stelle nach Druckgeräterichtlinie - Zertifizierungsstelle für Qualitätssicherungssysteme - der TÜV SÜD Industrie Service GmbH bescheinigt, dass das Unternehmen

AFRISO-EURO-INDEX GMBH
Lindenstraße 20
74363 Güglingen, Deutschland

für den Geltungsbereich

Herstellung und Vertrieb von Wassermangelsicherungen, Wasserstandsbegrenzern und Sicherheitsventilen als Ausrüstungsteile mit Sicherheitsfunktion nach EU-Baumusterprüfungen (Baumuster), gemäß Anlage

ein Qualitätssicherungssystem nach der Druckgeräterichtlinie 2014/68/EU Anhang III, Modul D eingeführt hat und anwendet.

Durch ein Audit, Bericht -Nr.: Q-IS-AN3-STG-PED-394-559-18, wurde der Nachweis erbracht, dass die betreffenden Anforderungen erfüllt sind.

Der Hersteller ist berechtigt, die im Rahmen des Geltungsbereiches dieses Qualitätssicherungssystems hergestellten Druckgeräte bei der Kennzeichnung mit unserer Kenn-Nummer wie dargestellt zu versehen:

CE 0036

Zertifikat - Nr. DGR-0036-QS-805-18
gültig bis 14. November 2021
unter der Voraussetzung von bestehenden jährlichen Überwachungsaudits
Filderstadt, 20. August 2018

TÜV SÜD Industrie Service GmbH
Wiesenstraße 199
80586 München
Germany

Peter Pak
Notified Body No.: 0036

Tel.: +49 711 70 05 289
Fax: +49 711 70 05 351
e-mail: marina.john@tuv-sud.de

TÜV SÜD Industrie Service GmbH • DGR-QS-Zertifizierungsstelle • Germany



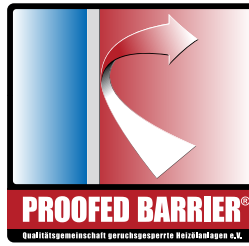

Zertifikat

Die Qualitätsgemeinschaft Geruchsgesperrte Heizölanlagen e.V. verleiht der Firma

AFRISO-EURO-INDEX GmbH
D-74363 Güglingen

für folgende Produkte:

- Membran-Antiheberventil MAV
- Kolben-Antiheberventil KAV
- Autom. Heizölkühler Flow-Control (auch Hochtemp. Variante)
- Autom. Heizölkühler FloCo-Top-1/-2/-1C/-2C (auch mit Optimum-Filter)
- Filtertypen: Einstrang (ggf. mit Rücklaufzuführung) und Zweistrang
- Tankentnahmeeinrichtung Euroflex (alle Ausführungen) und Miniflex
- Grenzwertgeber GWG 12
- Füllstandanzeiger MT-Profil

und deren Materialien zur Geruchsdichtheit

das Recht die Marke **PROOFED BARRIER®** zu führen

Die Verleihung erfolgt auf Grund des positiven Berichtes des Qualitätsschusses vom 27.09.2020 unter Zugrundelegung des Prüfungsberichtes des Fraunhofer Institutes für Verfahrenstechnik und Verpackung IVV, 85354 Freising vom 09.09.2020. Die Firma Afriso-Euro-Index GmbH unterwirft sich der laufenden Überwachung durch das Fraunhofer Institut IVV und den Regeln der Qualitätsgemeinschaft Geruchsgesperrte Heizölanlagen e.V. (QgH e.V.) sowie der Markensatzung der QgH e.V. in der jeweils geltenden Fassung.

Würzburg, den 28.09.2020

W. Dehoust
Wolfgang Dehoust

Vorsitzender der Qualitätsgemeinschaft Geruchsgesperrte Heizölanlagen e.V.



reddot award 2014 winner

The award "Red Dot" for high design quality, expressing innovation in form and function in an exemplary manner, is presented to:
Die Auszeichnung „Red Dot“ für hohe Designqualität, die in beispielhafter Weise Innovation in Form und Funktion ausdrückt, wird verliehen an:

FT
Room Temperature Sensor
Raumfühler

Manufacturer
AFRISO-Euro-Index GmbH,
Güglingen, Germany
In-house design
Eugen Mayer, Jürgen Fritz
Design
Kachel Industriedesign
(Markus Kachel),
Hein, Germany

From: 7 July 2014

Stefan Kachel
Stefan Kachel,
Munich, Germany

Nils Iben
Nils Iben,
Copenhagen, Denmark

Professor Danny Verlet
Professor Danny Verlet,
Brussels, Belgium

Professor Dr. Peter Zec
Professor Dr. Peter Zec,
Frankfurt am Main, Germany

13



TYPE APPROVAL CERTIFICATE

Certificate No: **TAAD000103**
Revision No: **1**

This is to certify:

That the **Pressure Indicator**

with type designation(s)

RF_ Series D4_ D7_ D8_ and D9_

Issued to

Afriso-Euro-Index GmbH
Amorbach, Germany

is found to comply with

DNV GL rules for classification - Ships, offshore units, and high speed and light craft

Application :

Product(s) approved by this certificate is/are accepted for installation on all vessels classed by DNV GL.

Temperature	D
Humidity	B
Vibration	B, C
EMC	Not relevant
Enclosure	C

Issued at **Hamburg** on **2017-06-08**

This Certificate is valid until **2022-05-31**.

DNV GL local station: **Augsburg**

Approval Engineer: **Didier Girardin**

for **DNV GL**

Joannis Papanuskas
Head of Section

This Certificate is subject to terms and conditions overlaid. Any significant change in design or construction may render this Certificate invalid. The validity date relates to the Type Approval Certificate and not to the approval of equipment/systems installed.

Form code: TA 251 Revision: 2016-12 www.dnvgl.com Page 1 of 2
© DNV GL 2014. DNV GL and the Horizon Graphic are trademarks of DNV GL AS.

Job Id: **262.1-005533-3**
Certificate No: **TAA0000103**
Revision No: **1**

Product description

Type : RF_ Version designation. Series D4_ , D7_ , D8_ and D9_ in any combinations as follows:

Type	Version	Series		
		1	2	3
RF	40	1	4	0
	50	7	1	2
	63	8	2	
	80	9	3	
	100	4		
160	5			

Application/Limitation

Tests carried out

Applicable tests according to Class Guideline DNVGL-CG-0339, Nov 2016

Marking of product

The products to be marked with:

- manufacturer name
- model name
- lot number (encoded - includes manufacturer name, model name, manufacturing date)

Manufacturing Places

- Afriso-Euro-Index GmbH Amorbach, Germany
- Afriso-Euro-Index SRL Bukarest, Romania
- Afriso Measurement & Control Technology Co.Ltd. Suzhou City, China

Periodical assessment

The scope of the periodical assessment is to verify that the conditions stipulated for the type are complied with, and that no alterations are made to the product design or choice of systems, software versions, components and/or materials.

The main elements of the assessment are:

- Ensure that type approved documentation is available
- Inspection of factory samples, selected at random from the production line (where practicable)
- Review of production and inspection routines, including test records from product sample tests and control routines
- Ensuring that systems, software versions, components and/or materials used comply with type approved documents and/or referenced systems, software, component and material specifications
- Review of possible changes in design of systems, software versions, components, materials and/or performance, and make sure that such changes do not affect the type approval given
- Ensuring traceability between manufacturer's product type marking and the type approval certificate

Periodical assessment is to be performed at least every second year and at renewal of this certificate.

END OF CERTIFICATE

Form code: TA 251 Revision: 2016-12 www.dnvgl.com Page 2 of 2

Information on the flange standard EN 1092 / international comparison of grades







Conversion to EN 1092

The new flange standard EN 1092-1 for all flange types has been in effect since June 2002. Currently, the old standards are still in use. However, this will change since the old standards are no longer maintained and updated. New standards will exclusively refer to EN 1092.

AFRISO flanges

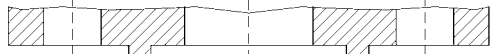
AFRISO usually ships type B1 flanges as per EN 1092.

This flange type differs from the former type C flanges as per DIN 2630 only in terms of the surface quality of the sealing surface. Flanges according to the old standard are available upon request.

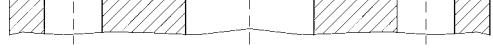
Flanges	Sealing surface	OLD (DIN 25../26..)			NEW (EN 1092-1)	
		Shape	Standard	R _z (µm)	Shape	R _z (µm)
Flat		A	DIN 2573	–	A	12.5 – 50
		B	DIN 2576	40 – 160		
Raised face		C	DIN 2630 to DIN 2638	40 – 160	B1*	12.5 – 50
		D		40		
		E		16	B2**	3.2 – 12.5
Spring		F	DIN 2512		C	3.2 – 12.5
Groove	N					
Spigot		V 13	DIN 2513		E	12.5 – 50
Recess		R 13				
Spigot		V 14	DIN 2514 for O rings		H	3.2 – 12.5
Recess		R 14				

* Typically PN 2.5 to PN 40.

** Typically PN 63 and PN 100.

Stainless steel – international comparison of grades

Material no.	DIN	AISI
1.4301	X 5 CrNi 18 10	304
1.4305	X 8 CrNiS 18-9	303
1.4310	X 12 CrNi 177 / X 10 CrNi 188	301
1.4401	X 5 CrNiMo 17 123	316
1.4404	X 2 CrNiMo 17 132	316 L
1.4435	X 2 CrNiMo 18 143	316 L
1.4462	X 2 CrNiMoN 22 53	318 L
1.4542	X 5 CrNiCuNb 16-4	630
1.4571	X 6 CrNiMoTi 17 122	316 Ti
1.4541	X 6 CrNiTi 18-10	321

DIN: Deutsches Institut für Normung

AISI: American Iron Steel Institute

Conversion table for standard pressure units

Unit	bar	mbar	Pa	kPa	MPa	kp/mm ²	kp/cm ²	atm	mmHg	mWC	mmWC	psi	"H ₂ O	"Hg
1 bar	1	1000	100000	100	0.1	0.01019716	1.019716	0.986923	750.062	10.19716	10197.16	14.50377	401.463	29.53
1 mbar	0.001	1	100	0.1	0.0001	0.0000101972	0.001019716	0.000986923	0.750062	0.01019716	10.19716	0.01450377	0.401463	0.02953
1 Pa	0.00001	0.01	1	0.001	0.000001	0.000000102	0.000010197	0.000009869	0.00750062	0.0001019716	0.1019716	0.000145038	0.00401463	0.0002953
1 kPa	0.01	10	1000	1	0.001	0.0001019716	0.01019716	0.00986923	7.50062	0.1019716	101.9716	0.1450377	4.01463	0.2953
1 MPa	10	10000	1000000	1000	1	0.1019716	1.019716	9.86923	7500.62	101.9716	10197.16	145.0377	4014.63	295.3
1 kp/mm²	98.0665	98066.5	9806650	9806.65	9.80665	1	100	96.7841	7355.9	1000	100000	1422.3344	39370.08	2895.9016
1 kp/cm²	0.980665	980.665	98066.5	98.0665	0.980665	0.0980665	1	0.967841	735.559	10	10000	14.223344	393.7008	28.959016
1 atm	1.01325	1013.25	101325	101.325	0.101325	0.01033227	1.033227	1	760	10.33227	10332.27	14.6959	406.38858	29.92126
1 mmHg	0.001333224	1.333224	133.3224	0.1333224	0.000133322	0.000013951	0.00135951	0.001315789	1	0.01360	13.60	0.019336	0.53524	0.03937
1 mWC	0.0980665	98.0665	9806.65	980.665	9.80665	0.00980665	0.1	0.0967841	73.556	1	1000	1.4223274	39.37008	2.8959016
1 mmWG	0.000098067	0.0980665	9.80665	0.00980665	0.000098067	0.000001	0.0001	0.000096784	0.073556	0.001	1	0.001422327	0.03937008	0.002895902
1 psi	0.06894757	68.94757	6894.757	689.4757	6.894757	0.006894757	0.070307	0.068046	51.715217	0.70307	703.07	1	2.768	2.03529
1 "H₂O	0.00249089	2.49089	249.089	0.249089	0.000249089	0.0000254	0.00254	0.002456317	1.86832	0.0254	25.4	0.03613	1	0.07356
1 "Hg	0.0338639	33.8639	3386.4	338.64	0.0033864	0.000345312	0.0345312	0.03342104	25.4	0.345316	345.316	0.49115	13.595	1

Information on the Pressure Equipment Directive (PED) 2014/68/EC

Pressure Equipment Directive (PED)

The European Pressure Equipment Directive (PED) came into force on May 30, 2002. The following paragraphs provide some information on the Directive itself and on our activities within the framework of this Directive.

- AFRISO-EURO-INDEX GmbH pressure gauges with a full scale value of > 0.5 bar are subject to the Pressure Equipment Directive and meet the appropriate requirements.
- Since the future application conditions of most pressure gauges are normally not completely known at the time of manufacture, we always manufacture our products in accordance with the most stringent criteria (gases of group 1).
- This way, our pressure gauges with a full scale value of 200 bar receive a CE mark according to the conformity assessment procedure.
- Pressure gauges with a connection flange of > DN 25 receive a CE mark with a full scale range of 0.5 bar and greater.
- The CE mark is attached to the outside of the housing (type designation plate).
- A declaration of conformity is provided on request.
- Detailed operating instructions and the appropriate data sheets are available at www.afriso.com. They can also be sent to you on request.
- Pressure gauges with a full scale value of less than 0.5 bar and loose chemical seals do not fall under the PED and must not carry a CE mark.
- Pressure gauges with a full scale value of between 0.5 bar and 200 bar fall under "Good Engineering Practice" and must not carry a CE mark (section 4, paragraph 3).
- We are not authorised to CE mark pressure gauges without a company name or a company logo.
- Pressure gauges which are used as a part of a safety system installed to protect against exceeding permissible limit values (equipment parts with a safety-related function) are treated separately.
- Our pressure gauges comply with the European Standards EN 837-1 and EN 837-3 and are manufactured and tested according to the appropriate requirements.

Selection criteria/safety considerations for pressure gauges as per EN 837-2

Medium	Liquid							
Housing	Without filling				With filling			
Nominal size	40/50/63/80		100/160/250		40/50/63/80		100/160/250	
Range bar	≤ 25	> 25	≤ 25	> 25	≤ 25	> 25	≤ 25	> 25
Code for minimum safety version	0	0	0	0	S1	S1	S1	S1
AFRISO type designation	All	All	All	All	D6/D7/D8	D6/D7/D8	D7/D8	D7/D8
Medium	Gas or steam (attention: not applicable to oxygen + acetylene*)							
Housing	Without filling				With filling			
Nominal size	40/50/63/80		100/160/250		40/50/63/80		100/160/250	
Range bar	≤ 25	> 25	≤ 25	> 25	≤ 25	> 25	≤ 25	> 25
Code for minimum safety version	0	S2	S1	S3	S1	S2	S1	S3
AFRISO type designation	All	"A"	D4/D9	RF 100/160 Si D4x2	D6/D7/D8	"B"	D6/D7/D8	RF 100/160 Si D8x2
<p>Explanations of key:</p> <p>"A" RF 63 Ch D 9x2, RF 63 Si D 4x2, RF 50/63 ST, RF 50/63 GT, RF 63 MK/IK D 3x2</p> <p>"B" RF 63 D 7x2, RF 63 Si D 8x2</p> <p>0 Pressure gauges without blow-out S1 Pressure gauges with blow-out S2 Safety pressure gauges without solid baffle wall S3 Safety pressure gauges with solid baffle wall (for higher safety level)</p> <p>Note 1: Pressure gauges for oxygen and acetylene must meet the requirements for safety pressure gauges (NS 40 – 80 S2, NS 63/100/160 S3).</p> <p>Note 2: Pressure gauges with glycerine filling must not be used for oxygen or other oxidation process fluids. High-concentration fluorine liquids and chlorinated liquids (for example, halocarbon) can be used for such applications.</p> <p>Note 3: This table contains the standard safety version with the corresponding keys. Users must take into consideration any information they have concerning their special requirements and may also use safety pressure gauges at pressures below than 25 bar.</p>								

i

Silicone-filled pressure measuring instruments may not be used in production facilities for paint and lacquer and in paint shop environments.

Selection criteria/safety considerations for pressure gauges as per EN 837-2

Pressure gauges for oxygen and acetylene

Only safety pressure gauges (S2 and S3) may be used.

All materials for wetted parts (parts coming into contact with oxygen or acetylene) must comply with EN 29539.

Pressure gauges for oxygen

The Bourdon tube and other wetted parts must be free from oil and grease. Only lubricants suitable for oxygen at maximum operating pressure may be used.

The dial must bear the word "oxygen" in English and the international symbol for "free from oil and grease" (symbol 0248 according to ISO 7000 with the "oil prohibited" symbol):

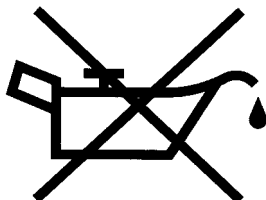

Oxygen and acetylene

	NG 40 – 80 S2/S3	NG 100 – 250 S3
Version	RF 50 ST RF 50 GT RF 63 ST RF 63 GT RF 63 MK/IK D 3x2 RF 63 Si D 4x2	RF 100 Si D 4x2 RF 160 Si D 4x2

Checklist for enquiries – level measurement

Company:	Project/enquiry:		
Quantity			
Requirements	<input type="checkbox"/> Level measurement with local display <input type="checkbox"/> Level measurement without local display <input type="checkbox"/> Min. level switch <input type="checkbox"/> Max. level switch <input type="checkbox"/> Level control <input type="checkbox"/> Other:		
Preferred measuring principle	Level detection: <input type="checkbox"/> PTC thermistor <input type="checkbox"/> Conductivity <input type="checkbox"/> Vibration <input type="checkbox"/> Capacitance	Continuous measurement: <input type="checkbox"/> Mechanical <input type="checkbox"/> Pneumatic <input type="checkbox"/> Capacitance <input type="checkbox"/> Hydrostatic <input type="checkbox"/> Ultrasonic <input type="checkbox"/> Guided micropulse (TDR)	
Required outputs	<input type="checkbox"/> 4–20 mA <input type="checkbox"/> 0–10 V <input type="checkbox"/> Limit level contacts, no.	<input type="checkbox"/> HART <input type="checkbox"/> Digital <input type="checkbox"/> Other:	
Required accuracy			
Medium to be measured			
Viscosity/density/granule size			
Dielectric constant (ϵ_r)			
Surface medium	<input type="checkbox"/> Calm Foam <input type="checkbox"/> Yes <input type="checkbox"/> Turbulent <input type="checkbox"/> No	Thickness: _____ Water content: _____	
Changing media	<input type="checkbox"/> Yes <input type="checkbox"/> No		
EX protection	<input type="checkbox"/> No <input type="checkbox"/> Yes, EX zone _____		
Approved overflow prevention system required	<input type="checkbox"/> No <input type="checkbox"/> Yes (WHG)		
Temperatures	T_{max} medium: T_{max} ambient: T_{min} medium: T_{max} ambient:		
Tank height / diameter			
Tank shape	<input type="checkbox"/> Cylindrical <input type="checkbox"/> Rectangular <input type="checkbox"/> Vertical <input type="checkbox"/> Horizontal		
Is the tank pressurised?	<input type="checkbox"/> Not pressurised <input type="checkbox"/> Yes, max. pressure _____ bar		
Tank with vacuum?	<input type="checkbox"/> No <input type="checkbox"/> Yes, max. vacuum _____ bar		
Required process connection	<input type="checkbox"/> G1B <input type="checkbox"/> G1½B <input type="checkbox"/> G2B <input type="checkbox"/> Flange: <input type="checkbox"/> Other:		
Mounting type	<input type="checkbox"/> Top mounting <input type="checkbox"/> Side mounting <input type="checkbox"/> Other:		
Location of tank	<input type="checkbox"/> Aboveground <input type="checkbox"/> Underground <input type="checkbox"/> In building <input type="checkbox"/> Outdoor		
Tank material			
Are there stirrers, struts or other obstructions in the tank (please enclose sketch)			

Checklist for enquiries – thermometers

Company:	Project/enquiry:
Quantity	
Application	
Medium to be measured	
Version	<input type="checkbox"/> Bimetal thermometer <input type="checkbox"/> Gas filled thermometer
Housing diameter	<input type="checkbox"/> 34 <input type="checkbox"/> 50 <input type="checkbox"/> 63 <input type="checkbox"/> 80 <input type="checkbox"/> 100 <input type="checkbox"/> 160 <input type="checkbox"/> 250
Range	
Connection position	<input type="checkbox"/> Bottom <input type="checkbox"/> Back <input type="checkbox"/> Every angle version
Connection type	<input type="checkbox"/> Plain <input type="checkbox"/> Loose male connection <input type="checkbox"/> Sep. screw-in thermowell <input type="checkbox"/> Loose union nut <input type="checkbox"/> Sep. weld-in thermowell <input type="checkbox"/> Compression fitting, adjustable <input type="checkbox"/> DIN/EN thermowell <input type="checkbox"/> Fixed male connection Neck <input type="checkbox"/> No <input type="checkbox"/> Yes _____mm
Connection thread	<input type="checkbox"/> G <input type="checkbox"/> NPT <input type="checkbox"/> BSPT <input type="checkbox"/> For welding <input type="checkbox"/> ¼ <input type="checkbox"/> ⅜ <input type="checkbox"/> ½ <input type="checkbox"/> ¾ <input type="checkbox"/> Other:
Stem length	
Mounting for capillary type	<input type="checkbox"/> Wall bracket <input type="checkbox"/> Back flange <input type="checkbox"/> 3-hole fixing, panel mounting bezel
Capillary length	
Housing	<input type="checkbox"/> Plastic <input type="checkbox"/> Sheet steel <input type="checkbox"/> Stainless steel with push on bezel <input type="checkbox"/> Stainless steel with bayonet bezel
Filling	<input type="checkbox"/> No filling <input type="checkbox"/> Glycerine <input type="checkbox"/> Silicone oil <input type="checkbox"/> Other:
Stem material	<input type="checkbox"/> Brass <input type="checkbox"/> Stainless steel <input type="checkbox"/> Other:
Protective pipe material	<input type="checkbox"/> Brass <input type="checkbox"/> Steel <input type="checkbox"/> Stainless steel <input type="checkbox"/> Other:
Dial	<input type="checkbox"/> Single scale as per EN <input type="checkbox"/> Dual scale: <input type="checkbox"/> Special scale: Customer logo <input type="checkbox"/> Yes <input type="checkbox"/> No
Accuracy class	Class <input type="checkbox"/> 1 <input type="checkbox"/> 2 as per EN 13190
Electrical contacts (only for gas filled thermometers)	<input type="checkbox"/> No <input type="checkbox"/> Magnetic spring contact <input type="checkbox"/> Inductive contact <input type="checkbox"/> Single <input type="checkbox"/> Dual switching function:
Other	

Checklist for enquiries – resistance thermometers

Company:	Project/enquiry:
Quantity	
Application	
Medium to be measured	
Temperatures	T _{max} medium: T _{max} ambient:
Pressure loads	Static: Dynamic from: from to
Measuring range	
Sensor	<input type="checkbox"/> 1 x <input type="checkbox"/> 2 x <input type="checkbox"/> Pt 100 <input type="checkbox"/> Pt 1000 <input type="checkbox"/> Other: <input type="checkbox"/> Class B <input type="checkbox"/> Class A as per IEC 751 <input type="checkbox"/> 2-wire <input type="checkbox"/> 3-wire <input type="checkbox"/> 4-wire
Neck	<input type="checkbox"/> No <input type="checkbox"/> Yes, length _____ mm <input type="checkbox"/> Material stainless steel 316 Ti <input type="checkbox"/> Other material:
Installation length	_____mm
Process connection	<input type="checkbox"/> Fixed male connection <input type="checkbox"/> Union nut <input type="checkbox"/> Compression fitting <input type="checkbox"/> G <input type="checkbox"/> NPT <input type="checkbox"/> M <input type="checkbox"/> Other: <input type="checkbox"/> ¼ <input type="checkbox"/> ½ <input type="checkbox"/> 18x1.5 <input type="checkbox"/> 14x1.5 <input type="checkbox"/> Other: <input type="checkbox"/> Mounting flange <input type="checkbox"/> Ø 41 mm <input type="checkbox"/> Ø 80 mm, adjustable <input type="checkbox"/> Clamp DN_____ <input type="checkbox"/> DIN 11851 DN_____ <input type="checkbox"/> Hygienic DN_____
Protective pipe	<input type="checkbox"/> Weld-in thermowell as per DIN: <input type="checkbox"/> Flanged thermowell, blind flange DN 25, PN 40 <input type="checkbox"/> Other:
Material for process connection or thermowell	<input type="checkbox"/> Stainless steel 316 Ti <input type="checkbox"/> Other:
Reduced measuring tip	<input type="checkbox"/> No <input type="checkbox"/> Yes <input type="checkbox"/> 6 mm <input type="checkbox"/> 4 mm
Required connection head or electrical connection	
Transmitter installation	<input type="checkbox"/> No <input type="checkbox"/> Yes, output signal <input type="checkbox"/> 4-20 mA <input type="checkbox"/> 0-10 V <input type="checkbox"/> Measuring range of transmitter:
Other	

Report

Function test level sensor / level sensor chain

Site of facility

Company _____

First name / last name _____

Street _____

Postcode / city _____

Product Manufacturer/ type

AFRISO GWG 12

Approval:
CE or Z-65.17-182 or PTB _____

AFRISO GWG 23

Approval:
CE or Z-65.17-366 or PTB _____

Manufacturer _____ Type _____

Measurement With level sensor tester GPG 01

With level sensor tester ME 5/6

With level sensor tester GPR 4

Electrical function test

Filling released

Heat-up time _____ seconds

Wet test

Switching off

Switch-off time _____ seconds

GWG level sensor chain

Yes No

Adjustment dimension E _____ mm (in tank)

Check dimension Y_E _____ mm (above tank)

Adjustment dimensions

The level sensor was set to the following dimensions:

Adjustment dimension X _____ mm (in tank)

Check dimension Y _____ mm (above tank)

Notes

Date of test:

Specialised company (as per WHG (AwSV)):

Company _____

First name / last name _____

Street _____

Postcode / city _____

Signature/stamp _____

Report

Function test liquid based leak detector LAS

Site of facility

Company

First name / last name

Street

Postcode / city

Product LAS 24, 39, 72 and 230
Approval: Z-65.24-381

- Checklist**
- Results of visual inspection of the system: Installation as per instructions, no visible damage.
 - The system was tested by opening the test valve.
 - The leak detection fluid escaped at a flow rate of at least 0.5 l/min.
 - The level of the leak detection fluid is correct.

Notes

Date of test:

**Specialised
company
(as per WHG
(AwSV)):**

Company

First name / last name

Street

Postcode / city

Signature/stamp

Report Function test liquid based leak detector LAG

**Site
of facility**

Company

First name / last name

Street

Postcode / city

Product

- LAG-13 KR Approval: Z-65.24-380 or CE or ÜHP
- LAG-14 ER Approval: Z-65.24-1 or EX5 11 02 15639 011 or CE or ÜHP

Checklist

- Results of visual inspection of the system: Installation as per instructions, no visible damage.
- The system was tested by opening the test valve.
- The leak detection fluid escaped at a flow rate of at least 0.5 l/min.
- When the probe was removed, the device triggered visual and audible alarms.
- When the test button was pressed, the device triggered visual and audible alarms.
- The audible alarm can be acknowledged.
- The operation and alarm lamps function properly.
- The level of the leak detection fluid is correct.

Notes

Date of test:

**Specialised
company
(as per WHG
(AwSV)):**

Company

First name / last name

Street

Postcode / city

Signature/stamp

Report

Function test vacuum type leak detector

Site of facility

Company

First name / last name

Street

Postcode / city

Product

LAZ-04/1 (HV)

Eurovac HV

Approval:
Z-65.22-4 or CE or ÜHP

LAZ-04/3 (NV)

Eurovac NV

Approval:
Z-65.22-382 or CE or ÜHP

Serial number

Measurement Measurements of the switching points yielded the following results:

Alarm on: _____ mbar

Pump on: _____ mbar

Alarm off: _____ mbar

Pump off: _____ mbar

Checklist

Results of visual inspection of the system: Installation as per instructions, no visible damage.

When the pressure exceeded the alarm pressure, the device triggered visual and audible alarms.

When the test button was pressed, the device triggered visual and audible alarms.

The audible alarm can be acknowledged.

The operation and alarm lamps function properly.

Condensate traps are installed at the lowest points of the hose lines.
The condensate traps have been emptied, if necessary.

Date of test:

Specialised company (as per WHG (AwSV)):

Company

First name / last name

Street

Postcode / city

Signature/stamp

Report

Function test pressure type leak detector

Site of facility

Company

First name / last name

Street

Postcode / city

Product

Europress LAD-10

Approval: Z-65.23-3

Europress

Approval: Z-65.23-3 or CE or ÜHP

Serial number

Measurement

Measurements of the switching points yielded the following results:

Alarm on: _____ mbar

Pump on: _____ mbar

Alarm off: _____ mbar

Pump off: _____ mbar

Checklist

Results of visual inspection of the system: Installation as per instructions, no visible damage.

When the pressure dropped below the alarm threshold, the device triggered visual and audible alarms.

When the test button was pressed, the device triggered visual and audible alarms.

The audible alarm can be acknowledged.

The operation and alarm lamps function properly.

Date of test:

Specialised company (as per WHG (AwSV)):

Company

First name / last name

Street

Postcode / city

Signature/stamp

Report

Function test protection equipment against siphoning

Site of facility

Company _____

First name / last name _____

Street _____

Postcode / city _____

- Product**
- KAV, piston type anti-siphon valve Approval: Z-65.50-415
- MAV, diaphragm type anti-siphon valve Approval: Z-65.50-415
- Diaphragm valve against siphoning Approval: _____

Measurement The function test was performed by means of the anti-siphon valve tester:

Measurement result: _____ bar

Siphoning protection **works**

Siphoning protection **does not work**

Measurement alternative: Test

The function test was not performed. A test by simulation of a line leak was performed by opening at the lowest point of the oil line. No significant amount of oil escaped.

KAV only: The adjustment value was adapted to the current level in the tank prior to the test and reset to the maximum possible level after the test.

Checklist

Results of visual inspection: Installation as per instructions, no visible damage.

The adjustment height was tested and lead-sealed.

The fuel oil consumer was started to de-aerate the fuel line and then stopped.

Adjustment value

Adjustment value for safe height: _____

Notes

Date of test:

Specialised company (as per WHG (AwSV)):

Company _____

First name / last name _____

Street _____

Postcode / city _____

Signature/stamp _____

General Terms of Delivery

of AFRISO-EURO-INDEX GmbH · Lindenstraße 20 · 74363 Güglingen · Germany

§ 1 Validity

- (1) All our deliveries, services and offers are exclusively made on the basis of the General Terms of Delivery. These General Terms of Delivery are part of all contracts with our contract partners (hereinafter referred to as "customers") we conclude pertaining to the deliveries or services provided by us. They also apply to all future deliveries, services or offers to the customer, even if they are not separately agreed again.
- (2) General terms and conditions of the customer shall only become part of the contract if we expressly consent to their validity in writing. This consent requirement shall apply in any and all cases, even if, for example, we carry out deliveries to the customer without expressly rejecting the customer's general terms and conditions even though we are aware of such terms and conditions.
- (3) Our General Terms of Delivery shall only apply if the customer is a business person (§ 14 BGB, German Civil Code), a legal person of public law or a public-law fund.
- (4) The General Terms of Delivery shall apply in particular to contracts covering the sale and/or delivery of movable goods ("goods"), regardless of whether we manufacture the goods ourselves or purchase them from suppliers (§§ 433, 631 BGB, German Civil Code). Unless otherwise agreed, the General Terms of Sale in the version valid at the time of the customer's order shall be deemed to be an outline agreement for future contracts of the same kind; we shall not be obliged to state their validity for each and every individual case.
- (5) Individual agreements with the customer (including supplementary agreements, amendments and modifications) which have been made in individual cases shall always take precedence over these General Terms of Delivery. The contents of such agreements shall be subject to a written contract and/or our written confirmation, subject to proof of the contrary.
- (6) Legally relevant declarations and notifications by the customer in relation to the contract (e.g. setting of a deadline, notification of defects, withdrawal or reduction) must be made in writing (e.g. letter, e-mail, fax). Statutory formal requirements and other evidence, especially in the event of doubts about the legitimacy of the declaring party, remain unaffected.
- (7) Any reference to the validity of statutory provisions is only for the purpose of clarification. Even without such a clarification, therefore, the statutory provisions shall apply if and to the extent that they have not been modified or expressly excluded in these General Terms of Delivery.

§ 2 Offer and conclusion of contract

- (1) All our offers are free and non-binding, unless they are expressly marked as binding or contain a certain acceptance period. We shall have the right to accept orders within a period of fourteen days after receipt.
- (2) The legal relationship between us and the customer shall be governed solely by the written purchase agreement, including these General Terms of Delivery. The written purchase agreement contains all agreements between the parties with regard to the contract. Any communication by us not made in writing prior to the conclusion of this contract is legally non-binding; any agreements of the contract parties not made in writing shall be replaced by the written contract, unless it is expressly stated that they shall be binding.
- (3) Amendments and modifications to the agreements, including these General Terms of Delivery, must be made in writing in order to be effective. With the exception of managers or authorized signatories, our employees are not entitled to make any differing verbal agreements. Transmission via telecommunication systems, in particular via fax or via e-mail, shall be deemed to be a sufficient instrument in writing, provided that the copy of the signed declaration is transmitted.
- (4) Any information or representation whatsoever on our part with regard to the delivery or service (such as, but not limited to weights, dimensions, performance values, loads, tolerances and technical data) shall be deemed to be approximate, unless

the usability for the purpose provided by the contract requires accurate conformity. Such information or representations do not constitute guaranteed characteristics, but descriptions or markings of the delivery or service. Any standard deviations and deviations which are made according to statutory provisions or which represent technical improvements, as well as the replacement of components by equivalent parts, are permissible if they do not impair the usability for the purpose intended by the contract.

- (5) We reserve the right to property or copyright to all offers and cost estimates submitted by us as well as to all drawings, illustrations, calculations, brochures, catalogues, models, tools and other documents and equipment provided to the customer. The customer shall not be permitted to disclose these objects, as such or in content, to third parties, to make them known, to use them himself or through third parties or to reproduce them. At our request, he shall be obliged to completely return such objects to us and to destroy any copies produced if they are no longer required by him in the normal course of business or if negotiations do not lead to the conclusion of a contract. Storage of data provided electronically for the purpose of standard data backup shall be the only exception to this.

§ 3 Prices and payment

- (1) The prices apply to the scope of services and delivery specified in the order confirmations. Additional or special services will be charged separately. The prices are in EURO ex works plus packaging, the applicable value added tax, and, for export deliveries, customs duties as well as fees and other public charges.
- (2) If the agreed prices are based on our list prices and if the delivery is to be effected more than four months after conclusion of the contract, our list prices valid at the time of delivery shall apply (minus any percentage discount or fixed discount that may have been agreed).
- (3) Invoices shall be payable within 30 days from the invoice date without any deduction, unless otherwise agreed in writing. The date of unconditional credit on our business account shall be decisive for payment in due time. Payment by check shall be excluded, unless agreed separately, as the case may be. If the customer does not pay by the due date, an interest of 5 % per year shall be due on the amounts payable; we shall be entitled to claim higher interest and further damages.
- (4) Any set-off with counterclaims of the customer or retention of payments due to such claims shall only be permissible if and to the extent that such counterclaims are undisputed or asserted by a court.
- (5) We shall be entitled to deliver or provide outstanding deliveries or services after prepayment or provision of security if, after the conclusion of the contract, we become aware of circumstances which substantially reduce the creditworthiness of the customer and which jeopardise the payment of our outstanding claims arising from the contract against the customer (including claims from other individual contracts pursuant to the same outline agreement).

§ 4 Delivery and delivery period

- (1) Deliveries are made ex works.
- (2) Time limits and deadlines for deliveries and services indicated by us are only approximate, unless a fixed deadline or a fixed date has been explicitly assured or agreed. If shipping has been agreed, delivery periods and delivery dates refer to the date of transfer to the forwarding agent, freight carrier or to any other third party in charge of shipping.
- (3) Without prejudice to our rights arising from default of the customer, we shall be entitled to demand from the customer an extension of delivery and performance periods or a postponement of delivery and performance dates for the period during which the customer does not meet his obligations pursuant to the contract.

- (4) We shall not be liable for impossibility of delivery or for delays in delivery, if such impossibility or delay is caused by force majeure or other events unforeseeable at the time of the conclusion of the contract which are beyond our control or for which we cannot be held responsible or which we have not caused (e.g. disruptions of operations of any kind, difficulties in procuring materials or energy, transport delays, strikes, lawful lockouts, lack of labour, energy or raw materials, difficulties in procuring necessary regulatory approvals, governmental measures, or incorrect or delayed supply by suppliers. Insofar as such events make the delivery or service substantially more difficult or impossible and the hindrance is not only of temporary duration, we are entitled to withdraw from the contract. In the case of hindrances of a temporary nature, the delivery or performance periods shall be extended or the delivery or performance dates shall be postponed by the period of the hindrance plus a reasonable start-up period. If, as a result of the delay, the customer cannot reasonably be expected to accept the delivery or service, the customer shall be entitled to withdraw from the contract, which is to be performed immediately by an instrument in writing.
- (5) We shall be entitled to deliver and provide partial deliveries and partial services only:
- if the partial delivery is reasonable for the customer and sufficient consideration is given to his legitimate interests,
 - if the delivery of the remaining ordered goods is assured and
 - if, as a result, the customer does not incur any substantial additional costs or additional efforts (unless we are willing to pay for such costs).
- (6) If we are in default with a delivery or service or if a delivery or service is impossible for any reason whatsoever, our liability for compensation shall be limited pursuant to provision § 8 of these general Terms of Delivery.

§ 5 Place of performance, shipping, packaging, passage of risk, acceptance

- (1) The place of performance for all obligations resulting from the contract shall be the registered office of our company in Güglingen, unless other agreements have been made. If the installation is part of the contract, the place of performance shall be the place at which the installation is to be performed.
- (2) The type of shipping and packaging are subject to our discretion. The cost of shipping and packaging shall be borne by the customer. If the customer requires drop shipping delivery, we shall charge a processing fee of EUR 10.00 for each delivery.
- (3) In cases of small orders with a net purchase value of less than EUR 100.00, we will charge a processing fee of EUR 15.00 in addition to shipping and packaging.
- (4) The passage of risk to the customer shall be the point in time of the transfer of the good to be delivered (the beginning of the loading process being decisive) to the forwarding agent, freight carrier or to any other third party in charge of shipping. This shall also apply in the case of partial deliveries or if we have undertaken other obligations (e.g. shipping or installation). If the shipment or the transfer is delayed for a reason caused by the customer, the transfer of risk shall be the day on which the good to be delivered is ready for shipment and we have notified the customer to this effect.
- (5) Storage costs incurred by us after transfer of risk shall be borne by the customer. If we store the goods to be delivered, the storage costs amount to 0.25% of the invoice amount of the delivered goods per completed week. We reserve the right to assert and prove further or lower storage costs.
- (6) We will insure the shipment for transport without recognizing any legal obligation to this effect.
- (7) If acceptance has to take place, the purchase item shall be deemed accepted if:
- the delivery and, provided we also have to perform installation, the installation are completed,
 - we have communicated this to the customer with reference to the deemed acceptance in accordance with this provision § 5 (7) and have prompted the customer to accept the delivery,
 - 12 business days have passed since the delivery or installation, or the customer has begun to use the purchased item (e.g. a delivered plant has been put into operation) and, in this case, six workdays have passed since delivery or installation, and
- within this period, the customer has refused acceptance for any reason other than for a defect of which the customer has notified us and which substantially impedes or makes impossible the use of the purchased item.

§ 6 Warranty, material defects, acceptance of the disposal obligation by the customer

- (1) The warranty period shall be one year from the date of delivery or, if acceptance is required, from the date of acceptance. This period shall not apply to claims for damages on the part of the customer resulting from injury to life, body or health or from wilful or grossly negligent breach of duty by us or our vicarious agents, which are subject to the limitation periods according to the statutory provisions.
- (2) The goods delivered must be carefully inspected immediately after delivery to the customer or to the third party designated by the customer. With regard to obvious defects or other defects which would have been recognizable in the case of an immediate, careful examination, they shall be deemed to be accepted by the customer if we do not receive written notification of defects within seven workdays after delivery. With regard to other defects, the delivery items shall be deemed to have been accepted by the customer if the notice of defect does not reach us within seven workdays after the date of detection of the defect; if the defect was already recognizable by the customer at an earlier point in time in normal use, this earlier point in time shall be decisive for the beginning of the complaint period. Upon request by us, a rejected delivery item must be returned to us free of freight charges. In the case of a justified complaint, we shall reimburse the costs of the least expensive type of shipping; this shall not apply if the costs increase because the delivery item is located at a place other than the place of the intended use.
- (3) In the case of material defects of the goods delivered, we shall first be obliged and entitled to rectify or replace the goods within a reasonable time. In case of failure, i.e. impossibility, unreasonableness, refusal or unreasonable delay of the improvement or replacement delivery, the customer shall be entitled to withdraw from the contract or to reasonably reduce the purchase price.
- (4) Insignificant or typical variations in colour, dimensions, weight and quality shall not be considered to be defects of the delivery items.
- (5) If a defect is the result of error on our part, the customer shall be entitled to claim damages under the conditions stipulated in provision § 8 hereto.
- (6) In the case of defects of components of other manufacturers, which we cannot remedy for license or actual reasons, we will, at our discretion, assert our warranty claims against the manufacturers and suppliers on behalf of the customer or assign them to the customer. In the case of such defects, there shall only be warranty claims against us subject to the other conditions and according to the provisions of these General Terms of Delivery and only if the aforementioned claims against the manufacturer and suppliers could not be enforced or if such enforcement is futile, for example, due to insolvency. During the duration of the legal dispute, the period of limitation of the customer's warranty claims against us shall be suspended.
- (7) The warranty shall be void if the customer modifies the delivery item without our consent or has it modified by a third party and such modification renders the rectification of the defect impossible or unreasonable. In any such case, the customer shall bear the additional costs arising from such modification for rectification of the defect.
- (8) If, in individual cases, a delivery of used items is agreed with the customer, such delivery shall be performed under exclusion of any warranty for material defects.
- (9) The customer shall be obliged to dispose of the delivered goods when they are no longer used at his own cost and in full compliance with all pertinent regulations. The customer shall indemnify us from the obligations pursuant to § 19, section 2 of the German Electronic Equipment Act (obligation of the manufacturer to take back the product) and from any claims of third parties related to this. The customer shall contractually oblige any other commercial third party to which the customer transfers the delivered goods to dispose of

such goods according to the pertinent regulations when such goods are no longer used. If the customer fails to contractually oblige third parties to which the customer transfers the delivered goods to take on the disposal obligation and to oblige his customers to take on such disposal obligation, the customer shall be obliged to take back the delivered goods at his own expense after the end of use and to dispose of them properly in accordance with the statutory provisions. Our claim to the above transfer of obligation/indemnification through the customer shall be extended by a period of limitation of two years after the final termination of the usage of the delivery item. The two-year period of suspension of the limitation shall not begin until we receive a written notice from the customer stating that he has ceased to use the device.

§ 7 Infringement of property laws

- (1) Pursuant to this provision § 7, we shall ensure that the delivery item is free from industrial property rights or third-party copyrights. Each contract partner shall immediately notify the other contract partner in writing if claims with regard to the infringement of such rights are asserted against him.
- (2) In the event that the delivery item infringes an industrial property right or copyright of a third party, we shall, at our discretion and at our expense, alter or replace the delivery item in such a way that no rights of third parties are infringed, but the delivery item continues to fulfil the contractually agreed functions; or we shall enter into a license agreement in order to obtain the right to use the delivery item for the customer. If we should not be able to succeed within a reasonable period, the customer shall be entitled to withdraw from the contract or to reasonably reduce the purchase price. Any claims for damages of the customer are subject to the restrictions of provision § 8 of these General Terms of Delivery.
- (3) In the case of infringements of laws by products of other manufacturers delivered by us, we shall, at our discretion, assert our claims against the manufacturers and suppliers on behalf of the customer or assign such claims to the customer. In these cases, there shall only be claims against us subject to the provisions of this provision § 7 and only if the aforementioned claims against the manufacturer and suppliers could not be enforced or if such enforcement is futile, for example, due to insolvency.
- (4) If an order is to be filled (designs, etc.) according to customer specifications, drafts or instructions, it is the sole responsibility of the customer to obtain all rights of commercial exploitation of the property rights that may be contained in his specifications, drafts or instructions. If the execution of an order according to specifications, etc. of the customer violates third-party property rights or labelling obligation, the customer shall undertake to indemnify us from any resulting claims for compensation, compensation for expenses and / or reimbursement of third parties.

§ 8 Liability for damages in case of fault

- (1) Our liability for damages, irrespective of the legal grounds, in particular from impossibility, delay, defective or incorrect delivery, breach of contract, breach of obligations in the case of contractual negotiations and tort, shall be limited subject to the provisions of this provision § 8.
- (2) We shall not be liable in the case of simple negligence on the part of our organs, legal representatives, employees or other vicarious agents, to the extent that this is not a violation of contractual obligations. Essential with regard to the contract are the obligation to deliver and/or install the delivery item in good time, its freedom from deficiencies in law and its freedom from defects which impair its functionality or usability more than insignificantly, as well as advisory, protection and custodial obligations which allow the customer to use the delivery item as per contract, or which serve the protection of the health or life of the customer's personnel or the protection of his property against substantial damage.
- (3) To the extent that we are liable for damages pursuant to provision § 8 (2) hereto, such liability shall be limited to damages which we have foreseen at the time of conclusion of the contract as a possible consequence of an infringement of the contract, or which we should have foreseen applying due diligence. Indirect damages and consequential damages which

are the result of defects of the delivery item shall only be subject to damages to the extent that such damage is typically to be expected when the delivery item is used as intended.

- (4) In the case of liability for simple negligence, our obligation to indemnify for damage to property and consequential financial loss shall be limited to the amount covered by our liability insurance and standard in our industry, even in the case of a breach of essential contractual obligations. Upon request, we will provide the customer with a corresponding insurance confirmation stating the amount covered by the liability insurance carrier.
- (5) The above exclusions and limitations of liability shall apply to the same extent on behalf of our organs, legal representatives, employees and other vicarious agents.
- (6) If we provide technical information or consultancy services and such information or services are not a part of the scope of services agreed upon by contract and owed by us, this shall be free of charge and without any liability whatsoever.
- (7) The limitations of this provision § 8 shall not apply to our liability for intentional conduct, for guaranteed characteristics, for injury to life, body or health or pursuant to the German Product Liability Act (Produkthaftungsgesetz).

§ 9 Retention of title

- (1) We retain the title to the sold goods until we have received full payment of all our present and future receivables arising from the purchase contract and from an ongoing business relationship (secured claims).
- (2) Prior to full payment of the secured claims, the goods subject to retention of title shall neither be pledged to third parties nor transferred to third parties for security. The customer shall notify us in writing immediately if an application for the opening of insolvency proceedings is filed or if third parties attempt to seize the goods under retention of title (e.g. by means of distraint or attachment).
- (3) In the case of a breach of contract by the customer, in particular in the event of non-payment of the purchase price due, we shall be entitled to withdraw from the contract pursuant to the statutory provisions and to reclaim the goods as a result of retention of title and withdrawal. If the customer does not pay the purchase price due, we shall only be entitled to assert these rights if we have previously set the customer a reasonable deadline for payment without success, or if such a deadline is not required pursuant to the statutory provisions.
- (4) The customer shall be entitled to resell and/or process the goods under retention of title in the ordinary course of business, subject to revocation pursuant to (c) below. In this case, the following provisions shall apply in addition.
 - (a) The retention of title shall cover the full value of the products resulting from processing, mixing or combining our products; we shall be deemed the manufacturer. If, in the case of processing, mixing or combining with goods of third parties, their rights of ownership remain, we shall acquire co-ownership to the ratio of the invoice amounts of the processed, mixed or combined goods. The same provisions that apply to the goods delivered under retention of title shall apply to the resulting new product.
 - (b) The customer shall assign to us, as a security, the claims arising against third parties from the resale of the goods or of the product in whole or to the amount of our possible co-ownership pursuant to the preceding paragraph. We accept the assignment. The obligations of the customer pursuant to provision § 9 (2) hereto shall also apply in respect of the assigned claims.
 - (c) The customer shall remain entitled to collect the claim in addition to us. We undertake not to collect the claim as long as the customer meets his payment obligations, as long as the customer performs and as long as we do not assert the retention of title by exercising a right pursuant to provision § 9 (3) hereto. If any of the above conditions are not met, we shall be entitled to request the customer to notify us of the assigned claims and the corresponding debtors and provide us with any information and the appropriate documents necessary for us to collect such claims, and to notify the debtors (third parties) of such assignment. In this case, we shall also be entitled to revoke the customer's authorization to resell and process the goods subject to retention of title.

(d) If the liquidable value of the securities exceeds our claims by more than 10 %, we shall, at the customer's request, release securities at our discretion.

§ 10 Final clause

- (1) If the customer is a merchant, a legal person under public law or a public-law fund or if the customer has no general court of jurisdiction in the Federal Republic of Germany, the place of jurisdiction for all disputes arising from the business relationship between us and the customer shall be our registered office in Güglingen or the registered office of the customer. However, in such cases, Güglingen shall be the exclusive place of jurisdiction for actions against us. This provision does not affect statutory provisions regarding exclusive places of jurisdiction.
- (2) The relations between us and our customers are subject exclusively to the laws of the Federal Republic of Germany. The United Nations Convention on Contracts for the International Sale of Goods (CISG) of April 11, 1980 shall not apply.
- (3) If and to the extent that the contract or these General Terms of Delivery contain gaps in the provisions, those statutory provisions shall be deemed to have been agreed upon which the contract parties would have agreed upon in view of the economic objectives of the contract and the purpose of these General Terms of Delivery if they had been aware of the gaps.

Note

The customer shall be deemed to have been notified that we store data relating to the contractual relationship pursuant to § 28 Bundesdatenschutzgesetz (German Federal Data Protection Act) for the purpose of processing such data and that we retain the right to disclose such data to third parties (e.g. insurance companies) if and to the extent such disclosure is required to perform the contract.

November 2020

Index

A

Accessories for		Overfill prevention system UFS 01 (WHG)	39
Alarm units	82–88	Temperature/pressure measuring instrument TDM 51 F	99
Anti-siphon valves	135	Transducer UFS 01 (WHG)	39
Fuel oil de-aerators/oil filters	148	Water alarm unit WWG	7
Leak detectors	55	Water valve WaterControl 01.1	98
Level sensors	32	AF-S inner linings for liquid fertiliser AHL, AdBlue®	58
Panel mounting and wall mounting	85	Air separators	165, 167
Pressure gauges	339–343	Air-Control	154
Rainwater harvesting	306–309	AK-S tank protection package (inner linings)	57
Solar pump assemblies	199–201	Angled quick air vent	159
Solar thermal equipment	196–201	Anode tester AT1	287
Actuator AVD, wireless	109	Anodes	287
Actuators ARM Pro Click	178	Antenna, EnOcean® wireless	119
Actuators for manifold systems	220	Anti-siphon valve tester	135
AdBlue® – inner lining	58	Anti-siphon valves	132–134
AdBlue® – level indicator	11	Anti-tamper cap valves	168
Additional alarm unit	88	App AFRISO TOOLBOX	246
AFRISO smart home system	91	App AFRISOhome	118
AFRISO TOOLBOX	246	App Eurosoft live	247
AFRISOhome – mobile app	118	ARM ProClick actuators	178
AFRISOhome gateway HG 02	116	AR-S inner lining for rainwater harvesting	59
AFRISO WATCHDOG-LINE (alarm units)	66–75	AR-SM rainwater lining	60
Backup controller kit RENA	309	ARV ProClick mixing valves	175
Boiler water low level alarm WMS-WP6	156	ATM mixing valves	297
Digital tank contents indicator DTA 10 / 20 E	12, 100	Automatic fuel oil de-aerators	139–146
Gas detector GM 2.1	81	Automatic radiator valves	258–265
Leak detectors Eurovac	52–54	Alarm units	
Leak detectors LAG	49–50	WATCHDOG-LINE	66–75, 77, 81
Level indicator TankControl 10	14	Wireless module TCM 320 for retrofitting	119
Minimelder/Maximelder-R	19	With EnOcean® wireless	120
Oil alarm unit OM 5	73		
Oil/water alarm unit ÖWU	74		
Oil/water alarm unit ÖWWG 3	71		
Oil-on-water detector ÖAWD-8	75		

B

Battery-operated tank contents gauge DTA	100
Burner controlled motorised boiler room vent	154
Boiler water low level alarm WMS-WP6	156
Boiler safety group assemblies KSG	161, 162
Bypass valve DÜ	170
Boiler filling and drain valves KFE	171
Boiler manifolds KSV	180
Base module BM Cositherm®	205
Base kit universal withdrawing system	28
Boiler safety group assemblies BFK 12	301
Backup controller kit RENA	309
Bourdon tube pressure gauges	317–336
BlueLine service instruments	406–415

C

Condensate trap KG 2	10
Control head, wireless	109
CO2 sensor	110
Cap for dipstick pipe	127
Conversion kit for withdrawal systems	129
Conversion kit float kit	129
Conversion kit shut-off valve	129
Chimney sleeve	155
Combustion controller FR 1	157
Connection combination diaphragm expansion vessels	163–164

Connection assembly for expansion vessel GAK	163–164
Combined air/flow filter	167
Charging unit for storage tank charging	190
Controller module Cositherm®	204–212
CosiTherm® single room temperature controller	204–213
Controller terminal bar WB 01	214
CAPBs® set valve balancing	248
CAPBs® set line balancing	249
Combination blocks for compact radiators	255, 261, 263
Combination blocks with thermostat	261, 271
Control heads for radiators	274, 109
Check valves (drinking water)	285
Chain anodes	287
Circulation system for hot water connection WZS	288–294
Circulation lance ZL 2	298
Circulation controller EC 1	299
Circulation switch ZS 2	300
Conversion kits for oil tanks	306
Cable extension fitting KVA	32
CAPBs®	32, 126
Capsule pressure gauges	337
Connection nipple for pressure gauges	343
Combined pressure gauge/thermometer	357–363
Coupling socket/plug	36
Control thermostats	384
CAPBs® sensor modules	408–415
Condensate bar	55
Combined alarm light and horn	86
Conductivity water sensors	96–97

D

DTA 20 E – tank contents indicator, wireless	100
Door contact, wireless	113
DTA 10 – battery-operated tank contents indicator	12
Digital tank contents indicators	12–13, 100
Diaphragm type anti-siphon valve MAV	134
Dual-line filters for fuel oil	137
Draft stabiliser WZB-1	155
Diaphragm safety valves	169, 199, 286
DA 10/12/14	17
Digital display units DA 10/12/14	17
Differential pressure bypass valve DÜ	170
Display and control units	17–18
Digital display and control unit VarioFox® 24	18
Dynamic thermostat valves Vario-DP	258
Drinking water mixing valves	297
Domestic water station HWSC	303
Damping device	342
Dipsticks	6
Detectors	66–69
Drip pan	85

13

DIN rail clip	85
---------------	----

E

Electro-thermostatic actuators TSA	220
Energy Harvesting	92

EnOcean® wireless, smart home products

CO ₂ sensor	110
Level switches	19
Gateway	116
Radiator actuator	109
Heat detector	102
Leak detectors	53–54, 62
Smoke alarm	101
Room temperature sensor	106
Repeater	119
Siren	114
Actuator	109
Tank contents indicators	100
Rocker switches	112
Temperature and pressure measuring instrument	99
Temperature and humidity sensor	108
Temperature control	103
Transmitters	111
Transmitters, temperature/humidity	107
Door/window contact	113
Alarm units	120
Water sensors	94–97
Water valves	98
EnOcean® wireless module TCM	119
Equipment for drinking water supply	285–305
Equipment for rainwater harvesting	306–309
Euroflex	128
Euroflex with tank heating	130
Europress	62
EuroSoft live app	247
Eurovac NV/HV	52–54
Extension module Zigbee	117
Extension universal withdrawal system	28

H

Handheld measuring instrument for line fittings and valves	248–249
Hand-held suction pump for fuel oil	148
Heat detector AHD 20	102
Heating circuit manifolds	225
Heating pump assembly PrimoTherm®	181
High-temperature fuel oil de-aerators	141
High-temperature level probes	41
HMS – fuel oil alarm unit	76
Horns	86
Hose connectors	8, 10, 61
Hot water circulation system WZS	288–294
Hot water mixing valves	297
Hybrid quick air vents	160
Hydraulic balancing	242
HydroFox® DMU 08	16
HydroFox® DMU 08	16
Hydrostatic level indicators	13–16

Inner tank linings for

Fuel oil, diesel and biodiesel	57
Liquid fertiliser AHL, AdBlue	58
Rainwater	59–60

K

KSG	161–162
KH 1 – horn	86

L

LAG container	51
LAG mounting kit	51
LAG spare parts	56
LAG-13 KR	49
LAG-14 ER	50
LAS 24/39/72/230	48
Leak detection fluid concentrate	51
Leak detectors	
LAS	48
Liquid-based	48–50
LAG	49-50
Vacuum	52–54
Eurovac NV/HV	53-54
Europress	62
Oil/water alarm unit ÖWWG 3	71
Oil/water alarm unit OM 5	73
Fuel oil alarm unit HMS	76

13

Indoor siren AIS 10	114
Immersion thermostats	392
Inner linings for tanks – mounting accessories	61
Inner linings	
Fuel oil, diesel and biodiesel	57
Liquid fertiliser AHL, AdBlue	58
Rainwater	59–60
Mounting accessories	61

Leak detectors for systems with liquid in the interstitial space	48	Manifold systems for heating and cooling	226–230
Level alarm	19	Maximelder-R	19
Level controllers	19, 43	Measuring instruments, portable	406
Level controls for emptying	43, 78	Measuring units CAPBs® for BlueLine measuring instruments	408–415
Level indicator for AdBlue	11	Mechanical boiler water low level alarm	156
Level indicators for fuel oil		Mechanical level indicators	6–7
Hydrostatic	13–16	Mechanical water sensor	95
Mechanical	6–7	Metallised sleeve	29
Pneumatic	8–12, 100	Miniflex	130
Level indicators for water		Minimelder/Maximelder probe, EnOcean® wireless	119
Hydrostatic	14–16	Minimelder-R	19
Pneumatic	8, 12, 100	Mixing valve ARV ProClick	175
Level probes DMU 08	16	Mixing valve drinking water	297
Level probes for overflow prevention systems	41	Mixing valves heating circuit water	175
Level sensor accessories	32	Mobile app AFRISOhome	118
Level sensor chain	26	Montagefix extension kit	10
Level sensor chain with withdrawing system	28	Motor for mixing valves	179
Level sensor combinations	28, 31	Motorised boiler room vent Air-Control	154
Level sensor tester	37	Mounting accessories for inner linings	61
Level sensors GWG	24–36	Mounting kits for	
Level switches		Fuel oil tank contents gauges	10
Minimelder, Maximelder-R	19	LAG	56
Liquid barrier	55	LAS	48
LS 300 – level probe	42	Water tank contents gauge	8, 12, 100
		Mounting valves for quick air vents	159
		MS, MSM	169
		MSS	199
		MSW	286
		MT-Profil R	7

M

MAG connection kit	199
Manifold systems for geothermal systems	235

N

NB 220 H/QS 40

O

Oil filter spanners 148

Oil filters 137

Oil tank conversion kits for rainwater 306–308

Oil vents 138–146

Oil withdrawal systems 128–130

Oil/water alarm unit OM 5 73

Oil/water alarm unit ÖWU 74

Oil/water alarm unit ÖWWG 3 71

Oil/water alarm unit with burner connection kit 72

Oil-on-water detector ÖAWD-1/-8 75

Open end spanner for replaceable filter 148

Opticlean ultra-fine filters 147

Optimum service box 14

Overfill prevention systems 39

13 Overpressure safety device 341

Sacrificial anodes 287

P

Paper filters Opticlean 147

Photoelectric probe 84

Pipe for dipstick 6

Piston type anti-siphon valve KAV 133

Plastic dipsticks 6

Plastic inner linings 57–60

Plastic manhole cover 307

Plastic quick air vents 160

Pneumatic level indicators 8–12, 100

Pneumofix 2 10

Pockets for thermometers 389

Pressure and temperature measuring instrument TDM 99

Pressure compensation unit DAE 131

Pressure gauges

- For heating installations 317–321
- For plant engineering 333
- Overpressure safety device 342
- Pressure gauges with capillary 322–332
- Pressure gauges with capillary tube 322–332
- Push-button stop cock 339
- Shut-off cocks and valves 339

Pressure gauges for heating installations 317–321

Pressure indicator for fuel oil filters 145

Pressure relief device 126

Pressure type leak detector 62

PrimoSol® – accessories 199–201

PrimoSol® – solar pump assemblies 196–198

PrimoTherm® – heating pump assemblies 181–195

PrimoTherm® Floor 130 231

PrimoVent quick air vents 158–160

Probes

- Conductivity 83
- ELT series 83
- Float 75
- Floor water 83

Probes

For alarm units	71, 83–84
Hydrostatic	13–15
Level	16
Minimelder/Maximelder	19
Photoelectric	73, 84
PTC thermistor	84
RENA	309
Wall rail	83
WMS-	156
ProCalida®	225–235
ProClick	175–179
Protective sleeve, metallised	29
PTC thermistor probe	84
Pull cord	131
Pump assemblies	
For heating circuit manifolds	231
For heating systems – PrimoTherm®	181–195
For increased return temperature	188, 190
Solar – PrimoSol®	196–198
With adjustable flow coefficient Kvs	186, 194
Push-button stop cock for pressure gauges	341

Q

Quick air vents	158
Quick air vents for solar systems	200

R

Room temperature sensors FT/FTF – wireless	106, 213
Radiator control head, wireless	109
Repeater	114–115, 119
Replaceable filter adapter	148
Room controller	204–219
Room temperature sensor D – wired	209
Room thermostats	216–219
RTL-Box 324 Vario	223
Radiator valves for hydraulic balancing	250, 258
Radiator valves	250, 258, 266
Radiator lockshield valves	253, 269
RENA – backup controller	309
Resistance thermometers	401–404
Radio-controlled water valve WaterControl 01.1	98
Reducers for	
Control and display unit VarioFox® 24	18
Level sensors	32
Level indicators	10

S

Smoke alarm – wireless	101
Switch, wireless	112
Siren for indoor spaces	114–115
Stainless steel sieve for fuel oil	136, 147
Sintered plastic sieves	136, 147
Single-line filters for fuel oil	137
Screw connections	148

Tank fittings	32	Thermostats with housing	390–400
Tank protection package AK-S	57	Immersion thermostats with housing GTT	392
Tank withdrawal systems	128–131	Room thermostats with housing GRT	396
TankControl 10	14	Room thermostats with housing TA 03	216
TankControl 10	14	Surface mounting thermostats with housing GAT	390
TAS 03 – thermal safety valve	157	Thermostats with housing GTK with capillary tube	394
Temperature and pressure measuring instrument TDM	99	Twin thermostats with housing GDT	398
Temperature control thermostats	384, 388	Thermowells for thermometers	370
Temperature controller CosiTherm®	204–213	Top filling system	27
Temperature controller FloorControl	214–219	Transducers	
Terminal bar for controlling surface heating systems	214	For overflow prevention systems (WHG)	39–42
Test gas bag PGT 10	82	LS 500	42
Test reports	435–439	NB 220 H/QS	40
Tester for safety-related equipment against siphoning	135	UFS 01	39
Thermal safety valve TAS 03	157	TSA – actuators	220–222
Thermometers		Type 76 A / AH level probe	41
Flue gas	367		
For air ducts	372		
For heating installations	364		
Industrial	372		
Industrial thermometers VMTh	382		
Stainless steel	377		
Surface	367		
With capillary tube	354–360		
Thermometers for heating installations	354–366		
Thermostat control head, wireless	109		
Thermostat control heads	274–281		
Thermostat valve bodies	250, 258, 266		
Thermostat valve bodies with measuring function	250		
Thermostatic actuators TSA	220–222		
Thermostatic mixing valves ATM	295–297		
Thermostats	390–400		

U

UFS 01	39
Unimes	7
Unitel	8
Unitop	9
Unitop-Set AdBlue	11
Universal withdrawal system	28

V

- Vacuum gauges for fuel oil filters 148
- Vacuum type leak detectors 52–54
- Valves
 - Anti-siphon 132–134
 - Anti-tamper cap 168
 - Check 285
 - Differential pressure bypass 170
 - Mounting 159
 - Pressure gauge shut-off 339
 - Radiator 250, 258, 266
 - Safety 169, 199, 286
 - Shut-off 129, 339
 - Valve bodies 250, 258, 26
- VarioFox® 24 18
- VarioQ 250–256
- Vent caps 127

- Withdrawal with level sensor chain 28
- Withdrawal systems 28, 128–130
- Water safety group assembly WSG 300
- WAF 04 – water filter 302
- Water filters WAF 04 302
- WATCHDOG-LINE alarm units 66
- Wall mounting rail probe WSS 83
- Warning light with rotating reflector 87
- Wireless standard EnOcean® 92
- Wireless water sensors 94–97
- WaterSensor 95–97
- Water valve, radio-controlled 98
- WaterControl 01.1 98
- Water sensors
 - WaterSensor eco 95
 - WaterSensor con 96
 - WaterSensor BWS 97
- Water alarm units
 - OM 5 73
 - ÖWU 74
 - WWG 77

W

13

- Wireless control 103
- Wireless temperature control 103
- Wireless room temperature sensor 106
- Wireless transmitters, temperature/humidity 107
- Wireless actuators 109
- Wireless rocker switch FT4F-rw 112
- Window contact AMC 20, wireless 113
- Wireless gateway 116
- WLAN gateway 116
- Wireless module TCM 320 119

Z

- ZAG 88
- Zigbee extension module 117
- Z-Wave extension module 117

TANK EQUIPMENT HEATING SYSTEMS ACCESSORIES ALARM UNITS SMART HOME WATER TECHNOLOGY

Technology for environmental protection
Measuring. Controlling. Monitoring.



AFRISO

AFRISO-EURO-INDEX GmbH
Lindenstraße 20
74363 Güglingen
Germany

Phone +49 7135 102-0
Fax +49 7135 102-147

info@afrioso.com
www.afrioso.com